

CONTENTS

	Page
Receiving Procedures.	1
Warranty.	1
Safety Information.	1 - 2
Machine Description.	3 - 4
Accessories.	3
Assembly Instructions.	4
Operating Instructions.	5
Maintenance.	5
Parts Lists and Diagrams.	6 - 7
Dimensions to Calculate Lost Load.	8

Operator’s Manual
for Morse
Extra Heavy-Duty Forklift-Karrier

Model 285A-GR
with Serial Number 414894 to _____

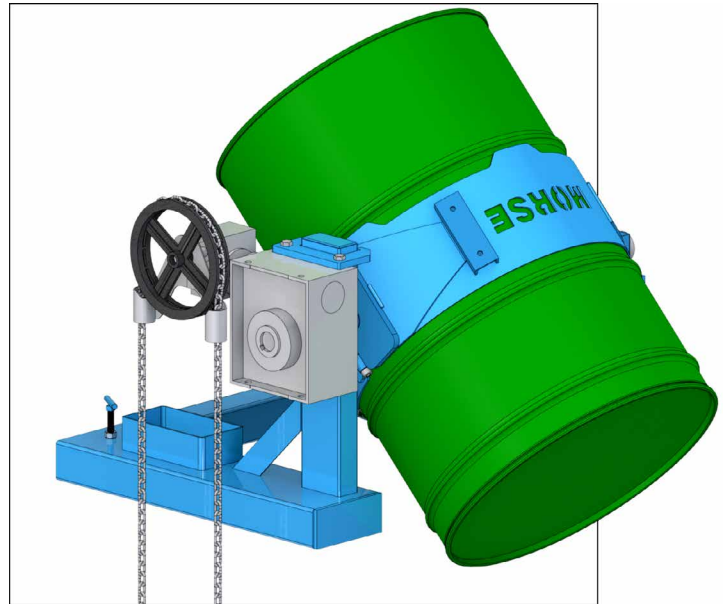

Receiving Procedures

Every Morse drum handler is inspected prior to shipping. However, damage may be incurred during transit.

- Check for visible damage. If you choose to accept damaged freight, always sign noting the damage on the **Bill of Lading**.
- Document the damage and have the truck driver sign. We recommend keeping a digital camera at your receiving dock for this purpose.
- Open packages expeditiously to check the condition of the goods. There is only a 24 hour window to notify the carrier of any concealed damage.
- Immediately **report all damage to the shipping company!** Then you may contact Morse for assistance with your freight claim.
- Morse Manufacturing will not be held responsible for any damaged freight that is not signed for as damaged.

Limited 2 Year Warranty

Morse drum handling equipment is guaranteed against defects in workmanship or materials for two years when used properly within its rated capacity. Warranty does not cover wear from normal use or damage from accident or abuse. Motors and other purchased parts carry the warranties of their manufacturers.

For warranty claims, contact your Morse Dealer to obtain a return authorization number, and for return freight advice. Return freight must be prepaid.

In all instances, liability is limited to the purchase price paid or to repairing or replacing the product. Customer assumes liability for any modifications, unauthorized repairs or parts substitution.

Safety Information

While Morse Manufacturing Co. drum handling equipment is engineered for safety and efficiency, a high degree of responsibility must be placed upon the machine operator to follow safe practices, based primarily on common sense, upon which true safety depends.

Failure to follow the safety precautions in this manual can result in personal injury or property damage. Observe the same precautions as with similar machinery where carelessness in operating or maintenance is hazardous to personnel. Carefully read the safety precautions below and throughout this manual.

Review the Material Safety Data Sheet(s) for the material(s) in the drum(s) and take all necessary precautions. Safety shoes, work gloves, hard hat and other personal protective devices are recommended.

Prior to initial use, inspect all moving parts and test rotation of chain wheel and drum holder assembly. Inspect drum holder assembly for proper operation. Perform necessary load test, inspections, operator training, etc.

Operator's Manual for Morse Extra Heavy-Duty Forklift-Karrier Model 285A-GR
Serial Number 414894 to _____

Safety Information (continued)

 **DANGER** - Indicates a situation which, if not avoided, will result in serious injury or death. This signal word is limited to the most extreme situations.

 **WARNING** - Indicates a situation which, if not avoided, could result in serious injury or death.

 **CAUTION** - Indicates a situation which, if not avoided, can result in damage to the machine.



CAUTION – Do Not Transport with Drum Raised. Always lower the drum holder to lowest position before transporting.



WARNING - The Extra Heavy-Duty Forklift-Karrier is designed to handle one drum of the types listed at the top of page 3. Machine Description. DO NOT attempt to handle any other type of drum or object. DO NOT exceed the weight capacity of 2000 Lb. (907 kg).



WARNING - Do Not Modify the Unit. Under no circumstances should any modifications be made to the Morse machinery without factory authorization. Any modifications may void the warranty. This machine was designed to perform a specific job and alterations may result in injury to operator or machine.



WARNING - No Loose Fitting Clothing. Wear close-fitting clothing and safety equipment appropriate to the job. Loose fitting clothing may become caught on the machinery and cause severe personal injury.



CAUTION - Wear safety shoes with non-slip soles and hard toe protection.



CAUTION: DO NOT allow drum to impact on floor, ground, or dumping station, etc.



WARNING: This product can expose you to chemicals including barium sulfate, cobalt, titanium dioxide, and 2-methylimidazole, which are known to the State of California to cause cancer, and bisphenol-A, which is known to the State of California to cause birth defects or other reproductive harm. For more information go to www.P65Warnings.ca.gov

Operator's Manual for Morse Extra Heavy-Duty Forklift-Karrier Model 285A-GR
Serial Number 414894 to _____

Machine Description

Model 285A-GR Extra Heavy-Duty Forklift-Karrier is designed to lift, transport, and dispense a ribbed 55-gallon (210 liter) steel drum 22.5" (57.2 cm) in diameter.

Maximum full-drum capacity is 2000 Lb. (907 kg). Capacity is derated to 1000 Lb. (454 kg) for half-full drum. Half-full rating is based on tilt mechanism's capacity for handling unbalanced, bottom-heavy drum.

MORSE
Mfg. Co., Inc.
E. Syracuse, NY

2000 Lb.
(907 kg)

Max. Capacity

The Specialist in Drum Handling Equipment

Made in U.S.A.

ACCESSORIES
to Install on EXISTING Drum Handler



Model # 55/30-19GR
Diameter Adapter
for 30-gallon (114 liter) drum. Insert Diameter Adapter into drum holder to handle a 19" (48.3 cm) diameter steel drum.

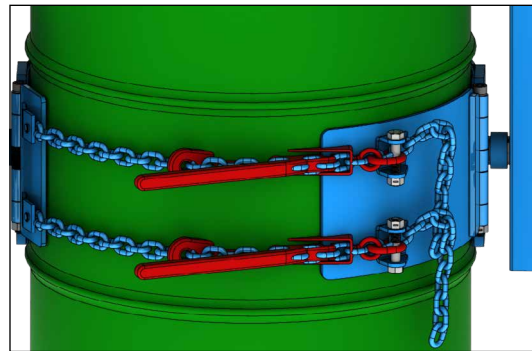

Kit # 6214KIT-P
Two Chains & Load Binders
Secure drum in holder with two chains and load binders. Replaces standard web straps and ratchets.



Kit # 2690GR-P
Hand Wheel
10" (25.4 cm) diameter Hand Wheel with speed knob. Replaces standard pull chain to turn drum.



Kit # 1460-P
Hand Crank
9" (22.9 cm) Hand Crank. Replaces standard pull chain to turn drum.

Operator's Manual for Morse Extra Heavy-Duty Forklift-Karrier Model 285A-GR
Serial Number 414894 to _____

Important

1. Review the Material Safety Data Sheet(s) for the material(s) in the drum(s) and take all necessary precautions. Safety shoes, work gloves, hard hat and other personal protective devices are recommended.
2. Please read all instructions thoroughly before attempting to operate your new Morse drum handler.
3. Model 285A-GR has maximum capacity rating of 2000 Lb. (907 kg) full drum and 1000 Lb. (454 kg) half-full drum and is designed to lift, move and pour a 55-gallon (210 liter) steel drum. DO NOT exceed these ratings. Exceeding these ratings or handling drums other than those mentioned above is unsafe and could result in equipment damage, excessive wear or awkward handling.
4. When loading, unloading, operating, or maintaining your MORSE drum handler, always use care and good judgment. Maintain secure footing and a firm hold. Keep hands and loose clothing away from all moving parts. Never allow anyone to be below any part of a raised drum handler or drum. Read operating instructions and review the pictures in the sales brochure before operation.
5. Because the model 285A-GR is a front-end attachment for a forklift, OSHA recommends that "... the truck (forklift) be marked to identify the attachment(s) and show the approximate weight of the truck and attachment combination at maximum elevation with load laterally centered." See center of gravity dimensions of model 285A-GR on page 7 for calculating lost load on your equipment.
6. Prior to initial use, inspect all moving parts and test rotation of chain wheel and saddle assembly. Inspect saddle assembly for proper operation. Perform necessary load test, inspections, operator training, etc.

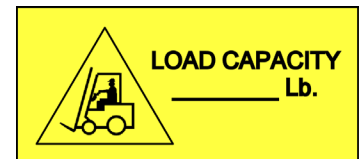

CAUTION: DO NOT exceed weight capacity of 2,000 Lb. (907 kg) for FULL drum, 1,000 Lb. (454 kg) for HALF-FULL drum.



CAUTION: DO NOT allow drum to impact on floor, ground, or dumping station, etc.

Assembly Instructions

1. Remove the following items from the small cardboard box packaged with the 285A-GR: chain wheel, chain guide with pull chain, and roll pin.
2. Slide chain wheel with pull chain onto speed reducer input shaft with the chain guide facing outward as pictured in parts diagram.
3. Insert 3/16 roll pin into the chain wheel on the input shaft of the speed reducer.
4. Prior to initial use, inspect all moving parts and test rotation of chain wheel and saddle assembly. Inspect ratchets and web straps for proper operation. Perform necessary load test, inspections, operator training, etc.

Operator's Manual for Morse Extra Heavy-Duty Forklift-Karrier Model 285A-GR
Serial Number 414894 to _____

Operating Instructions

1. Before sliding forklift forks into fork tubes, adjust forks to an inside spread of 25" (63.5 cm) minimum. Lock forks into position on forklift carriage.
2. Drive forklift forward to slip forks into fork tubes of base frame. Tighten tee screws to secure Forklift-Karrier to forks. Transport Forklift Karrier to drum to be handled.
3. Swing open ratchet hinge plate and strap hinge plate.
4. Drive forklift with Forklift Karrier near floor level to position drum holder (saddle) band around middle of drum between ribs.
5. Secure drum into drum holder. Thread each strap through slot in ratchet. Operate ratchets to tighten straps against drum.
6. Remove pull chain from chain box on base frame and place end of loop near operator's seat.
7. Raise forks to clear floor and transport drum in vertical position to dispensing location. While transporting, ensure that drum is raised away from floor to prevent drum bottom from interfering with a pallet or other obstacle.
8. To pour drum: pull on chain, rotating drum to angle required for dispensing. To control pouring angle of drum, pay out one side of chain and pull other side to prevent drum from free-wheeling.
9. When dispensing is completed, rotate drum back to vertical and return drum. Remove drum by operating ratchet to loosen each web strap around drum. Release straps from ratchets and swing open both hinge plates.

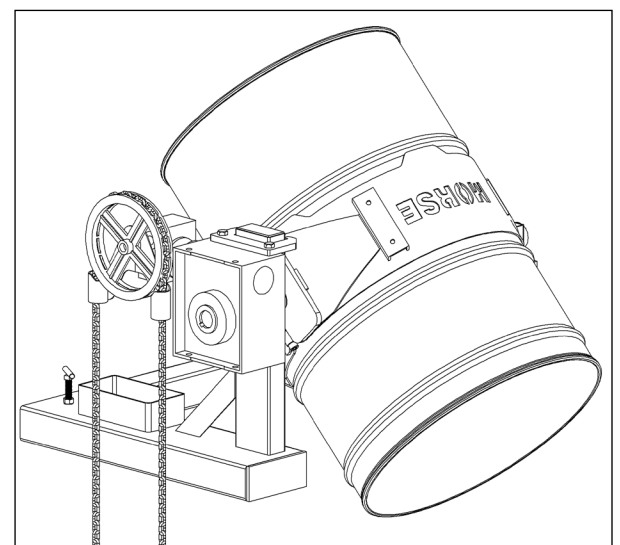
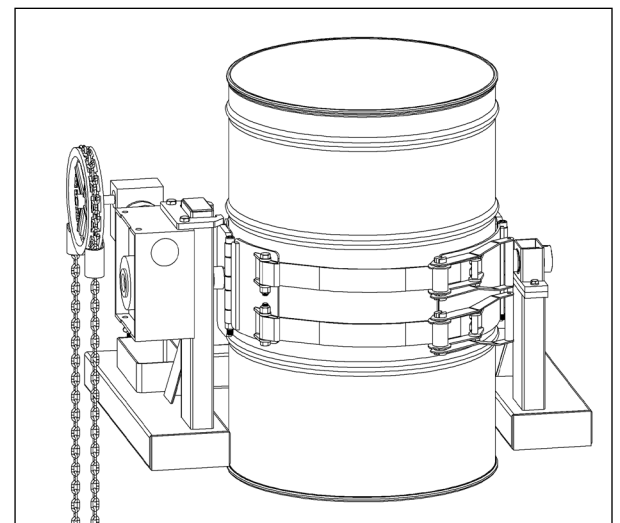
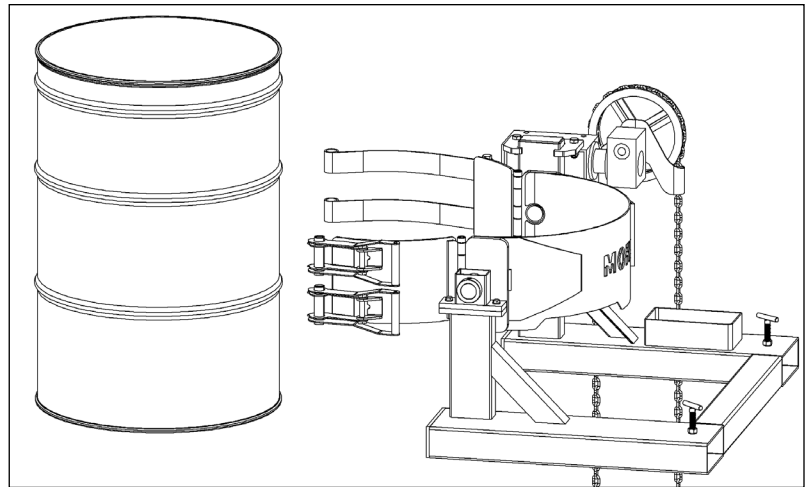

Maintenance

1. Periodically inspect all moving parts, framework, ratchets, straps and contact areas for signs of wear, fatigue, or loosening. Tighten, adjust or replace parts as necessary to prevent failure and maintain proper function.
2. Worn or damaged parts must be properly replaced with the correct, genuine Morse parts.
3. Web strap should be removed from service & replaced if any of the following are visible:
 - Acid or caustic burns
 - Melting or charring of any part of the strap
 - Holes, tears, cuts, snags or embedded articles
 - Broken or worn stitching in load bearing splices
 - Excessive abrasive wear
4. Speed reducer has been filled and tested prior to shipment. No maintenance is required.

Operator's Manual for Morse Extra Heavy-Duty Forklift-Karrier Model 285A-GR
Serial Number 414894 to _____

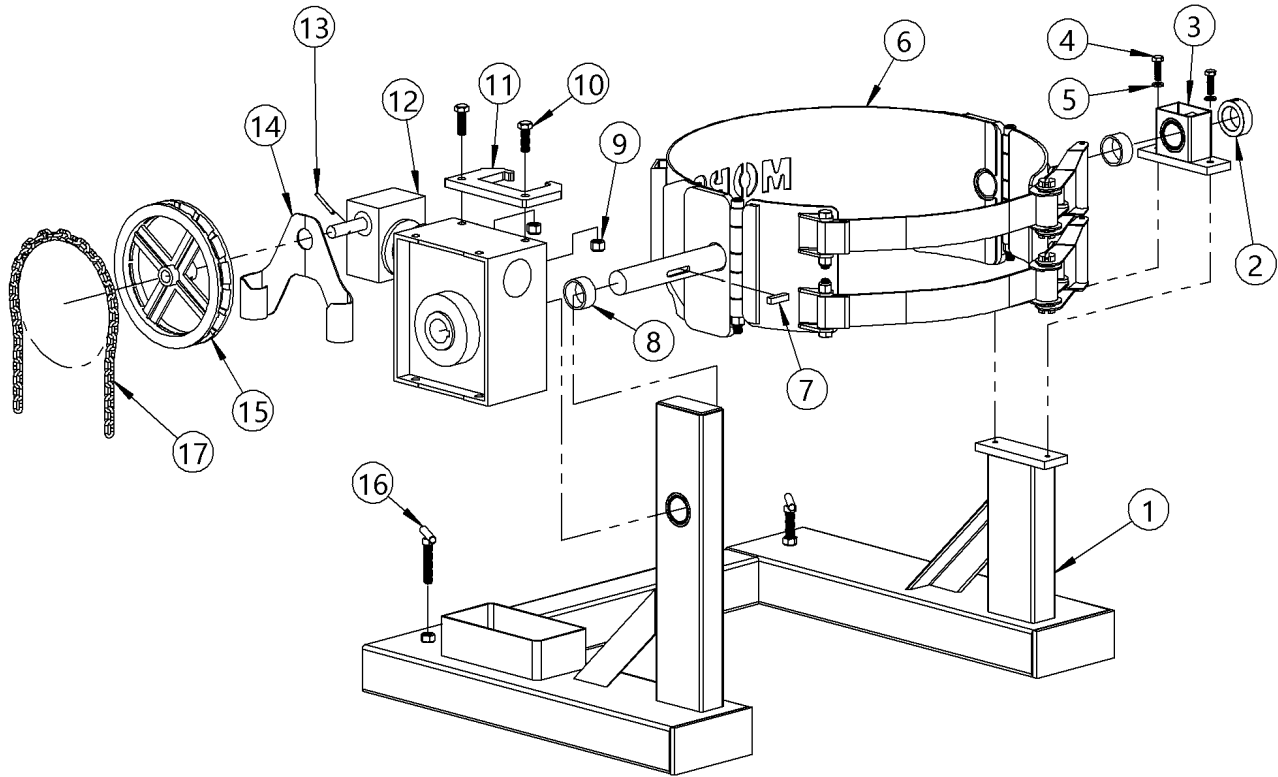

ITEM NO.	PART NUMBER	DESCRIPTION	QTY.
1	6834-P	BASE FRAME GR XGR	1
2	570-P	COLLAR, 1-1/2" ID	1
3	595-P	IDLER BEARING ASM, 285A-GR	1
4	535-P	HHCS, 3/8-16 X 1-1/4 GR 5 ZINC	2
5	1474-P	WASHER, 3/8 SPLIT LOCK	2
6	5991-P	SADDLE ASM, GR, 195 STRAP	1
7	6812-P	KEY, 3/8" X 1.5", GR XGR	1
8	5184-P	SPACER, GR SADDLE, PIPE	2
9	6266-P	NUT, 1/2-13 NYLON LOCK	2
10	2172-P	HHCS, 1/2-13 X 1-1/2 GR5	2
11	5940F-P	TORQUE PLATE, 285A-GR XGR	1
12	6287-P	SPEED REDUCER, A-GR, 150:1	1
13	5269-P	ROLL PIN, 3/16 X 1-3/4	1
14	5245-P	GUIDE, POCKET CHAIN WHEEL	1
15	1303-P	POCKET CHAIN WHEEL, 3/4 BORE	1
16	58-P	SET SCREW, LOCK TEE, 285	2
17	3-285-P	CHAIN, PULL, POCKET 20' LENGTH	1

Operator's Manual for Morse Extra Heavy-Duty Forklift-Karrier Model 285A-GR
Serial Number 414894 to _____



PART # 5991-P
SADDLE (DRUM HOLDER) ASSEMBLY

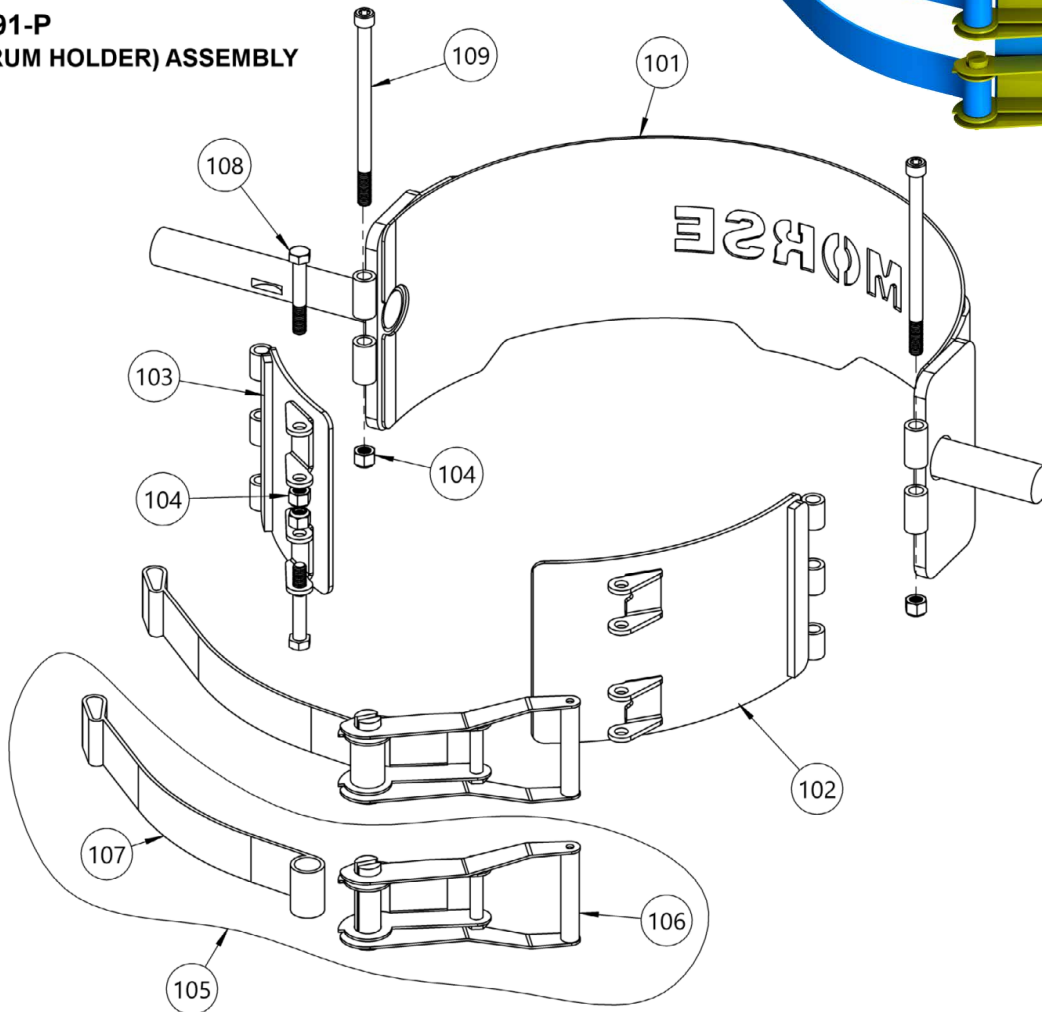

ITEM NO.	PART NUMBER	DESCRIPTION	QTY.
101	5991W-P	SADDLE WELD, GR, 195, STRAP	1
102	5187-P	HINGE PLATE, GR, RATCHET	1
103	6006-P	HINGE PLATE, GR, DRIVE	1
104	6266-P	NUT, 1/2-13 NYLON LOCK	4
105	4449-P	STRAP ASM W/ RATCHET	2
106	5498-P	RATCHET ONLY, 4449-P	1
107	5497-P	WEB STRAP ONLY, 4449-P	1
108	6272-P	HHCS, 1/2-13 X 3-1/4"	2
109	6294-P	SHCS, 1/2-13 X 8"	2

Operator's Manual for Morse Extra Heavy-Duty Forklift-Karrier Model 285A-GR
Serial Number 414894 to _____

MORSE MODEL 285A-GR

Center of gravity shown for Morse attachment combined with max drum: 2,188lb [993kg]
 (285A-GR net weight 188lb)

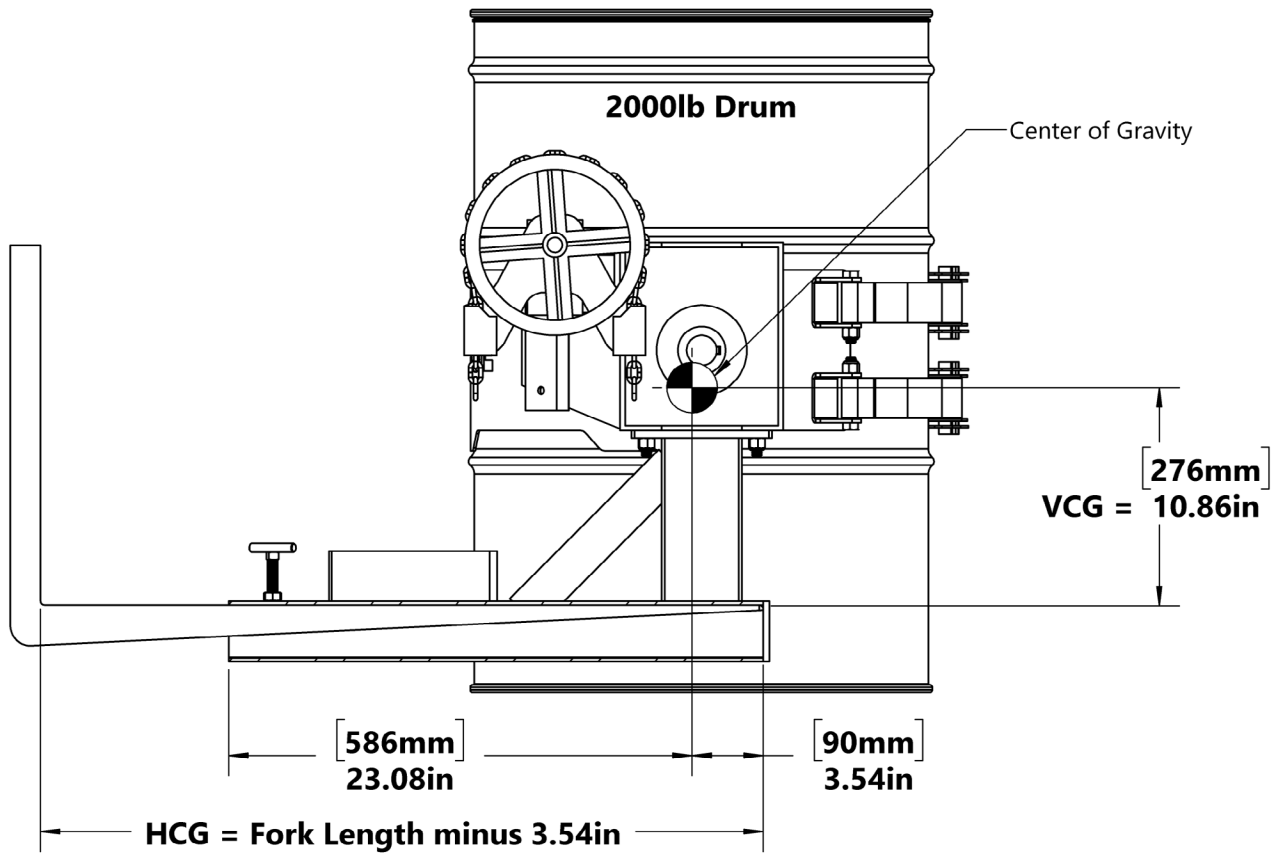

(DIMENSIONS ASSUME FORKS ARE TOUCHING FORK TUBE END CAPS.)