

**CONTENTS**

	Page
Receiving Procedures. . . . .	1
Warranty. . . . .	1
Safety Information. . . . .	1 - 2
Machine Description. . . . .	3 - 4
Operating Instructions. . . . .	4 - 5
Maintenance. . . . .	4
Dimensions to Calculate Lost Load. . . . .	5
Parts Lists and Diagrams. . . . .	6 - 8
Recommended Spare Parts . . . . .	9

**Operator’s Manual**  
for Morse Forklift-Karrier with  
3-Piece Drum Holder  
Model 285G

Serial Number 0616 to \_\_\_\_ (MMYY)

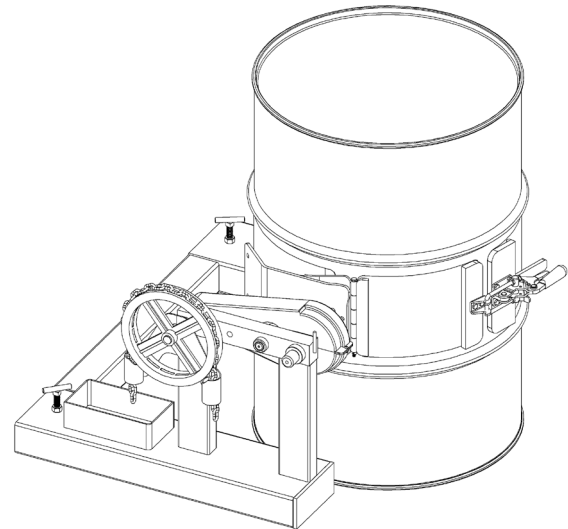

**Receiving Procedures**

Every Morse drum handler is inspected prior to shipping. However, damage may be incurred during transit.

- Check for visible damage. If you choose to accept damaged freight, always sign noting the damage on the **Bill of Lading**.
- Document the damage and have the truck driver sign. We recommend keeping a digital camera at your receiving dock for this purpose.
- Open packages expeditiously to check the condition of the goods. There is only a 24 hour window to notify the carrier of any concealed damage.
- Immediately **report all damage to the shipping company!** Then you may contact Morse for assistance with your freight claim.
- Morse Manufacturing will not be held responsible for any damaged freight that is not signed for as damaged.

**Limited 2 Year Warranty**

Morse drum handling equipment is guaranteed against defects in workmanship or materials for two years when used properly within its rated capacity. Warranty does not cover wear from normal use or damage from accident or abuse. Motors and other purchased parts carry the warranties of their manufacturers.

For warranty claims, contact your Morse Dealer to obtain a return authorization number, and for return freight advice. Return freight must be prepaid.

In all instances, liability is limited to the purchase price paid or to repairing or replacing the product. Customer assumes liability for any modifications, unauthorized repairs or parts substitution.

**Safety Information**

While Morse Manufacturing Co. drum handling equipment is engineered for safety and efficiency, a high degree of responsibility must be placed upon the machine operator to follow safe practices, based primarily on common sense, upon which true safety depends.

Failure to follow the safety precautions in this manual can result in personal injury or property damage. Observe the same precautions as with similar machinery where carelessness in operating or maintenance is hazardous to personnel. Carefully read the safety precautions below and throughout this manual.

Review the Material Safety Data Sheet(s) for the material(s) in the drum(s) and take all necessary precautions. Safety shoes, work gloves, hard hat and other personal protective devices are recommended.

Prior to initial use, inspect all moving parts and test rotation of chain wheel and saddle assembly. Inspect saddle assembly for proper operation. Perform necessary load test, inspections, operator training, etc.

**Operator's Manual for Morse Forklift-Karrier with 3-Piece Drum Holder Model 285G**  
**Serial Number 0616 to \_\_\_\_ (MMYY)**

**Safety Information** (continued)

 **DANGER** - Indicates a situation which, if not avoided, will result in serious injury or death. This signal word is limited to the most extreme situations.

 **WARNING** - Indicates a situation which, if not avoided, could result in serious injury or death.

 **CAUTION** - Indicates a situation which, if not avoided, can result in damage to the machine.



**WARNING** - The Forklift-Karrier is designed to handle one drum of the types listed at the top of page 3. Machine Description. DO NOT attempt to handle any other type of drum or object. DO NOT exceed the weight capacity of 800 Lb. (363 kg). Exceeding these ratings is unsafe and could result in equipment damage, excessive wear or awkward handling.



**WARNING** - Do Not Modify the Unit. Under no circumstances should any modifications be made to the Morse machinery without factory authorization. Any modifications may void the warranty. This machine was designed to perform a specific job and alterations may result in injury to operator or machine.



**WARNING** - No Loose Fitting Clothing. Wear close-fitting clothing and safety equipment appropriate to the job. Loose fitting clothing may become caught on the machinery and cause severe personal injury.



**CAUTION** - Do Not Transport with Drum Raised. Always lower the drum holder to lowest position before transporting.



**CAUTION** - Wear safety shoes with non-slip soles and hard toe protection.



**CAUTION:** DO NOT allow drum to impact on floor, ground, or dumping station, etc.



**WARNING:** This product can expose you to chemicals including barium sulfate, cobalt, titanium dioxide, and 2-methylimidazole, which are known to the State of California to cause cancer, and bisphenol-A, which is known to the State of California to cause birth defects or other reproductive harm. For more information go to [www.P65Warnings.ca.gov](http://www.P65Warnings.ca.gov)

**Operator's Manual for Morse Forklift-Karrier with 3-Piece Drum Holder Model 285G**  
**Serial Number 0616 to \_\_\_\_ (MMYY)**

**Machine Description**

The Model 285G Forklift-Karrier is designed to lift, transport, and dispense a ribbed 55-gallon (210 liter) steel drum 22.5" (57 cm) in diameter. The maximum full-drum capacity is 800 Lb. (363 kg). The capacity is derated to 500 Lb. (227 kg) for a half-full drum. The half-full rating is based on the tilt mechanism's capacity for handling an unbalanced bottom-heavy drum.



**Options**

- A 19" (48 cm) diameter ribbed 30-gallon (114 liter) steel drum can be handled with Model 55/30-19GR Diameter Adapter installed.

**MORStop™ Tilt-Brake**  
Kit # 3900-P

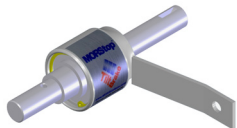

Kit for customer to install Tilt-Brake on EXISTING manual tilt drum handler. Automatically holds drum tilt angle until you move it.

**Hand Crank or Hand Wheel**  
Replace standard pull chain to turn drum



9" (22.9 cm)  
Hand Crank  
Kit # 1460-P

16" (40.6 cm)  
diameter  
Hand Wheel with  
speed knob  
Kit # 2690-P



**Diameter Adapter**  
for 19" (48 cm) diameter drum  
Model # 55/30-19GR

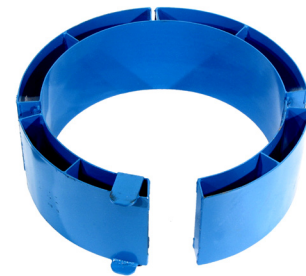

**Important**

1. Please read all instructions thoroughly before attempting to operate your new Morse drum handler.
2. When loading, unloading, operating, or maintaining your MORSE drum handler, always use care and good judgment. Maintain secure footing and a firm hold. Keep hands and loose clothing away from all moving parts. Never allow anyone to be below any part of a raised drum handler or drum. Read operating instructions and review the pictures in the sales brochure before operation.
3. This model is a front-end attachment for a forklift, OSHA recommends that "... the truck (forklift) be marked to identify the attachment(s) and show the approximate weight of the truck and attachment combination at maximum elevation with load laterally centered." See center of gravity dimensions on page 5 for calculating lost load on your equipment.

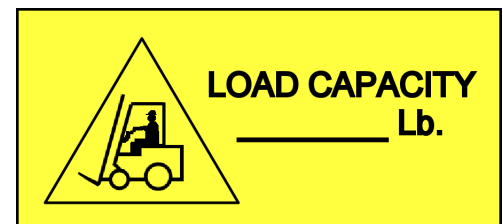

**Operator's Manual for Morse Forklift-Karrier with 3-Piece Drum Holder Model 285G**  
Serial Number 0616 to \_\_\_\_ (MMYY)

**Operating Instructions**

1. Before sliding forklift forks into the fork tubes, adjust forks to an inside spread of 25" (63.5 cm) minimum. Lock forks into position on the forklift carriage.
2. Drive the forklift forward to slip the forks into the fork tubes. Tighten tee screws to secure the Forklift Karrier to the forks.
3. Open the toggle clamp by activating the release lever and swing both hinged bands to the open position. Push Kontrol-Karrier against drum so that saddle will encircle drum.
4. Drive the forklift with the Forklift Karrier near floor level to position the saddle band around the middle of the drum between the ribs.
5. Secure the drum: Close the two hinged bands around the drum, latch the toggle clamp (see detail A).
6. Remove pull chain from chain box on base frame and place end of loop near operator's seat.
7. Raise forks to clear the floor and transport drum in vertical position to dispensing location.
8. Pour drum by pulling on the pull chain loop, rotating drum to angle required for dispensing. To control the pouring angle of the drum, pay out one side of chain and pull the other side to prevent the drum from free-wheeling.
9. If the Forklift-Karrier is equipped with the MORStop Tilt-Brake, there is no need to hold tension on both sides of the chain loop. Braking is immediate and self-actuating, without additional steps by the operator. To add the MORStop Tilt-Brake to your Forklift-Karrier, order kit for field installation (part # 3900-P).
10. When dispensing is completed, rotate the drum back to vertical and return drum. While transporting, ensure that the drum is raised away from the floor to prevent the drum bottom from interfering with a pallet or other obstacle.

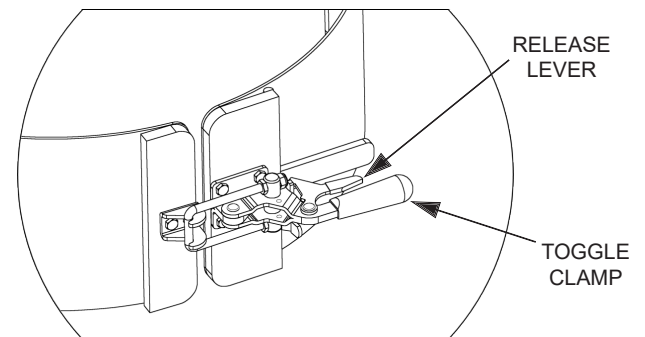
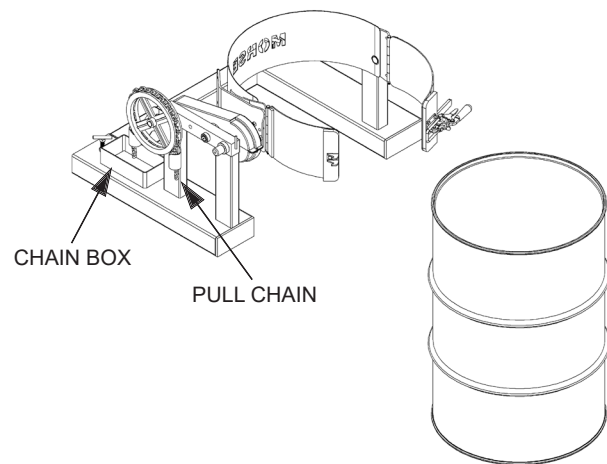
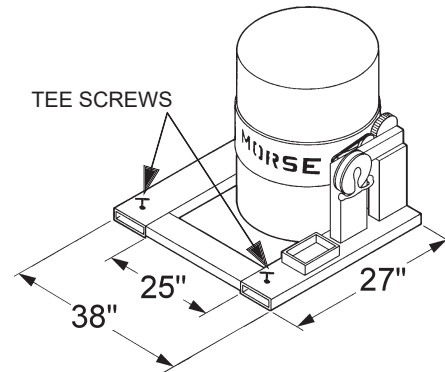

Detail A

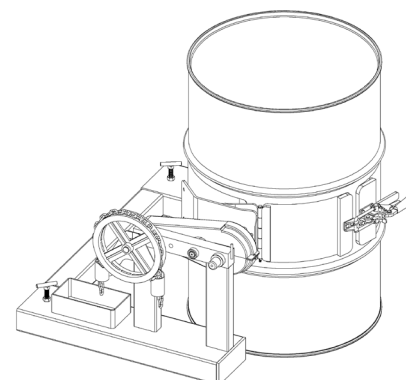

**Maintenance**

Periodic inspection for the general condition of structural and mechanical components is imperative for safe and efficient operation.

1. Lubricate gear teeth and roller chain.
2. Clean and oil saddle hinges and other moving parts periodically. Clean and lubricate more often in environments where dust, dirt or other foreign particles will effect the performance of moving parts.
3. Periodically inspect all moving parts, framework, drum holder and contact areas for signs of wear, fatigue, or loosening. Tighten, adjust, or replace parts as necessary to prevent failure and maintain proper function.
4. Worn or damaged parts must be properly replaced with the correct, genuine Morse parts.

**Operator's Manual for Morse Forklift-Karrier with 3-Piece Drum Holder Model 285G**  
**Serial Number 0616 to \_\_\_\_ (MMYY)**

**MORSE MODEL 285A**

Center of gravity shown for Morse attachment combined with max drum: 958lb [435kg]  
 (Applies to models: 285A, 285AM, 285G approx net weight 149lb)

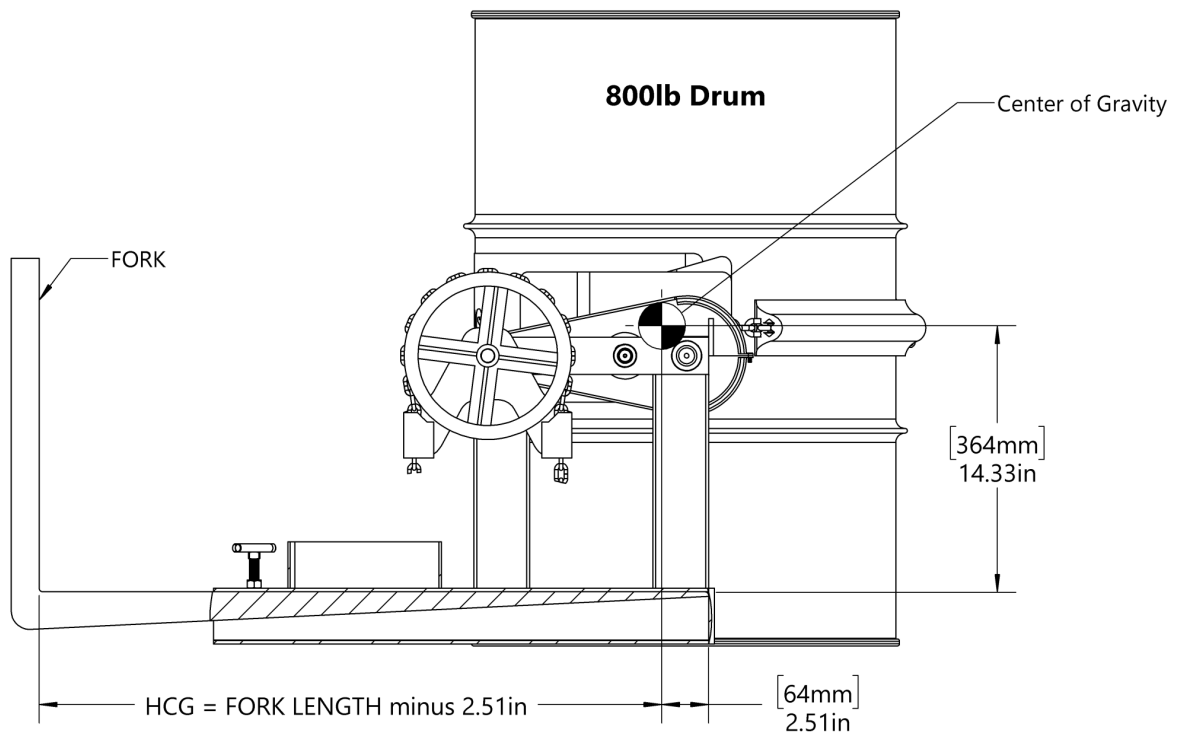

(DIMENSIONS ASSUME FORKS ARE TOUCHING FORK TUBE END CAPS.)

Operator's Manual for Morse Forklift-Karrier with 3-Piece Drum Holder Model 285G  
Serial Number 0616 to \_\_\_\_ (MMYY)

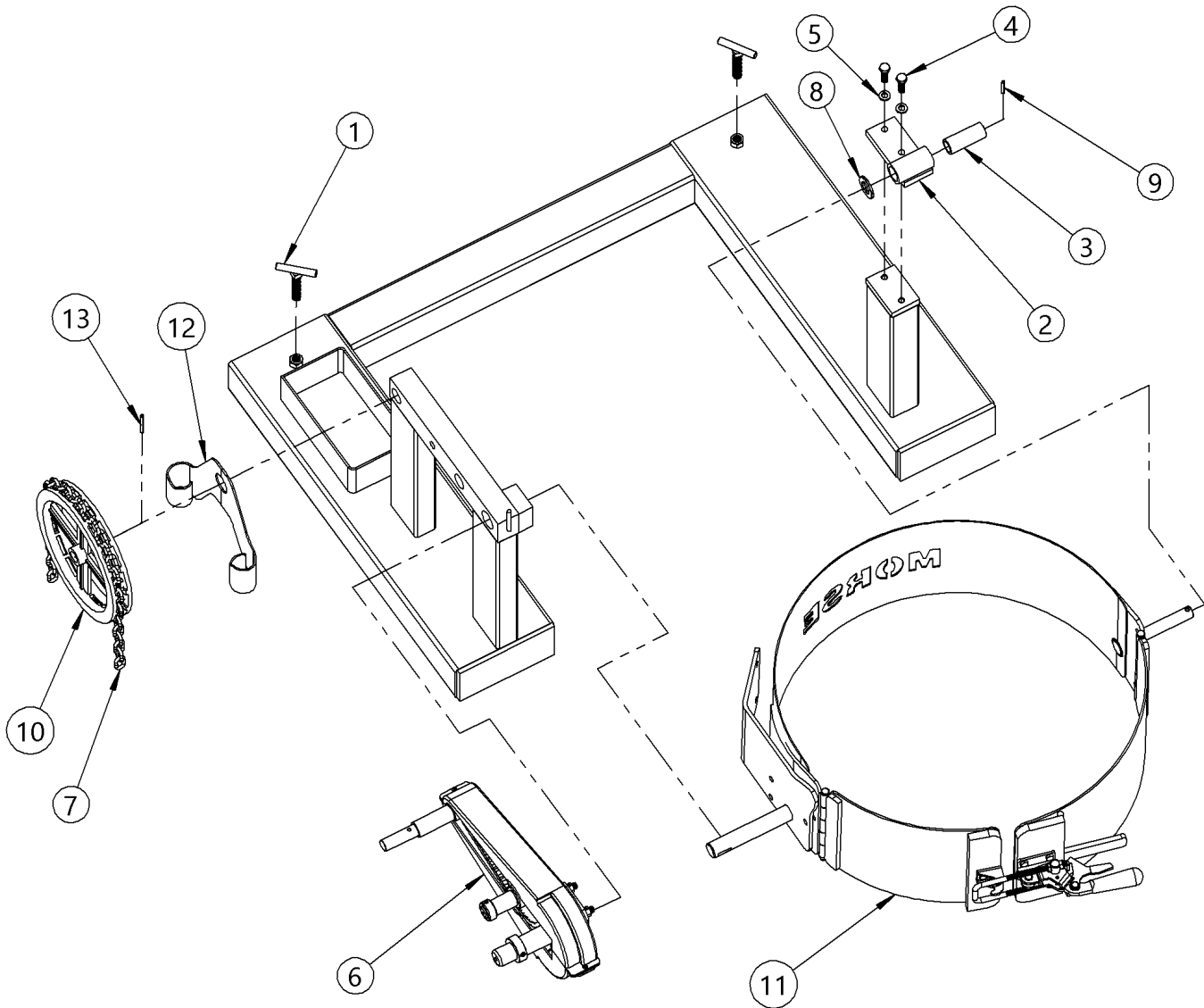

ITEM NO.	PART NUMBER	DESCRIPTION	QTY.
1	58-P	SET SCREW, LOCK TEE, 285	2
2	3849-P	SLIDING IDLER BEARING WELD	1
3	19-P	BEARING, 3/4" ID X 2-1/2"	1
4	535-P	HHCS, 3/8-16 X 1-1/4 GR 5 ZINC	2
5	1474-P	WASHER, 3/8 SPLIT LOCK	2
6	→	<b>POWER TRAIN: SEE NEXT PAGE</b>	1
7	3-285-P	CHAIN, PULL, POCKET 20' LENGTH	1
8	55-P	WASHER, 3/4 SAE FL 1-1/2 OD	1
9	64-P	ROLL PIN, 3/16 X 1-1/4	1
10	1303-P	POCKET CHAIN WHEEL, 3/4 BORE	1
11	5000G-P	SADDLE ASM, MORCINCH, 3PC	1
12	5245-P	GUIDE, POCKET CHAIN WHEEL	1
13	5269-P	ROLL PIN, 3/16 X 1-3/4	1



Operator's Manual for Morse Forklift-Karrier with 3-Piece Drum Holder Model 285G  
Serial Number 0616 to \_\_\_\_ (MMYY)

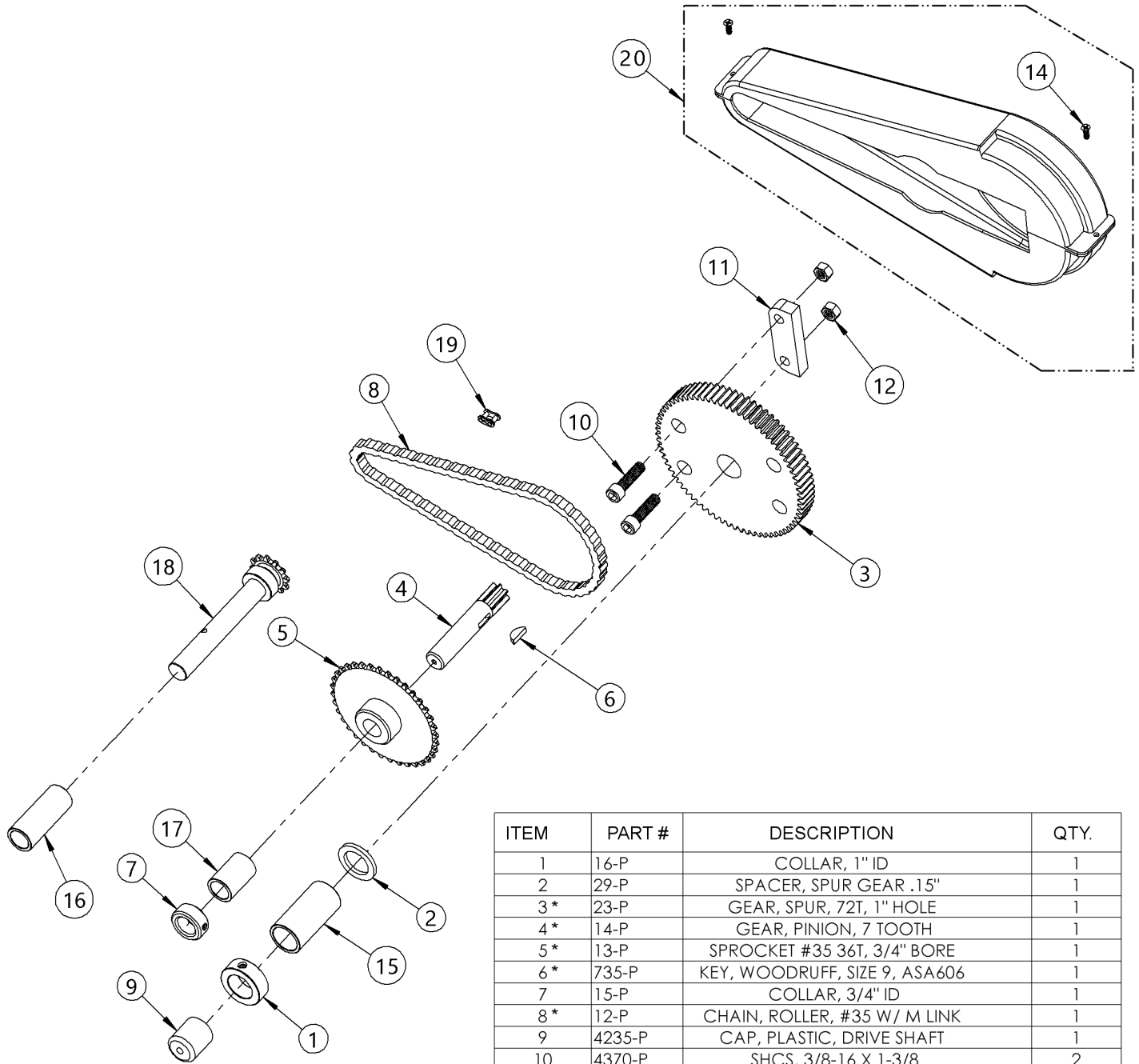

ITEM	PART #	DESCRIPTION	QTY.
1	16-P	COLLAR, 1" ID	1
2	29-P	SPACER, SPUR GEAR .15"	1
3*	23-P	GEAR, SPUR, 72T, 1" HOLE	1
4*	14-P	GEAR, PINION, 7 TOOTH	1
5*	13-P	SPROCKET #35 36T, 3/4" BORE	1
6*	735-P	KEY, WOODRUFF, SIZE 9, ASA606	1
7	15-P	COLLAR, 3/4" ID	1
8*	12-P	CHAIN, ROLLER, #35 W/ M LINK	1
9	4235-P	CAP, PLASTIC, DRIVE SHAFT	1
10	4370-P	SHCS, 3/8-16 X 1-3/8	2
11	4473-P	SPACER, SPUR GEAR, U	1
12	1169-P	NUT, 3/8-16 REV HEX LOCK	2
14	4481-P	SCREW, 8-32 X 1/2", FH	2
15*	18-P	BEARING, 1" ID X 2-1/2"	1
16*	19-P	BEARING, 3/4" ID X 2-1/2"	1
17*	7-P	BEARING, 3/4" ID X 1-1/2"	1
18*	5135-P	SHAFT, 12T SPROCKET & SPACER	1
19	795-P	LINK, MASTER, #35 CHAIN	1
20	4285-P	COVER SET, BLK POLY 30:1 REG	1

\* Recommended spare parts

**Operator's Manual for Morse Forklift-Karrier with 3-Piece Drum Holder Model 285G**  
**Serial Number 0616 to \_\_\_\_ (MMYY)**

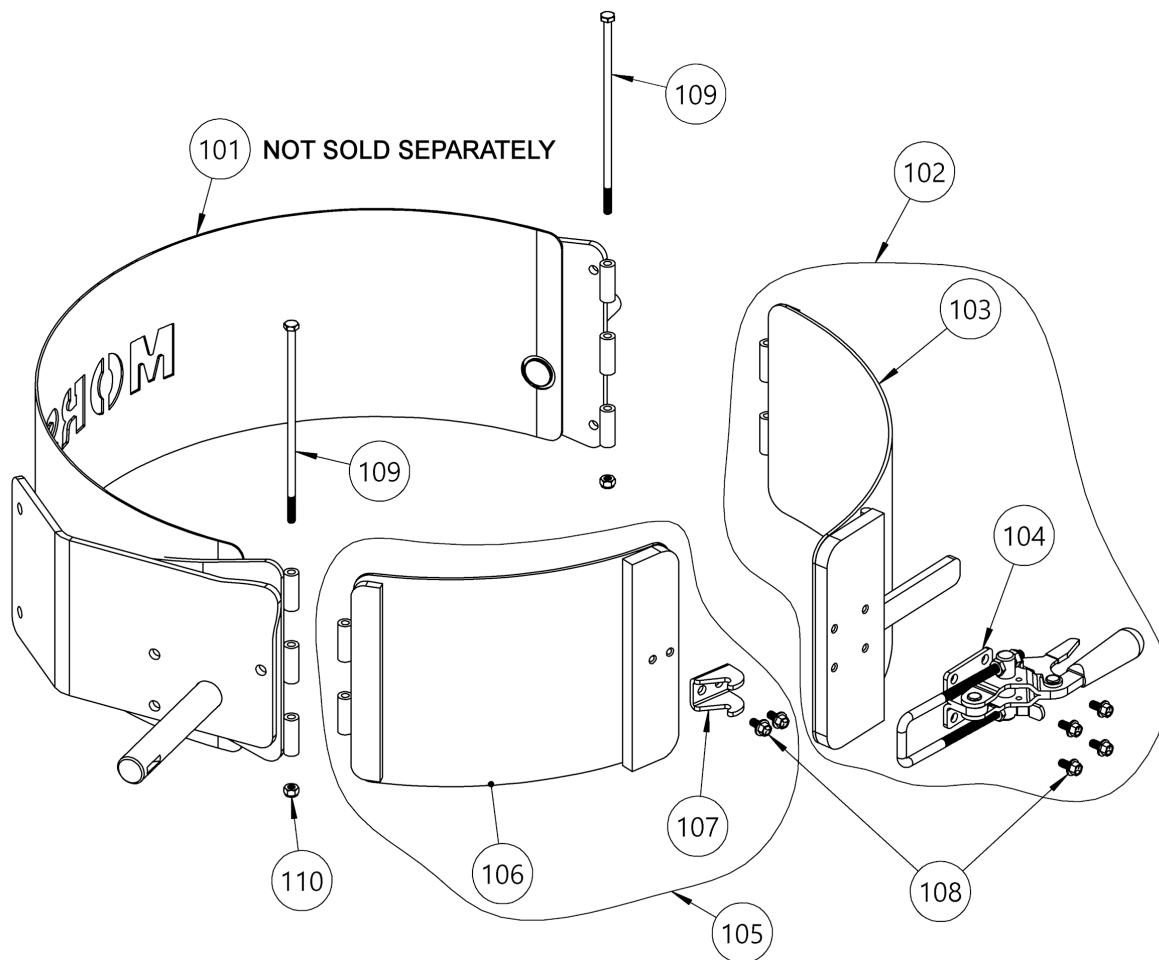

ITEM NO.	PART NUMBER	DESCRIPTION	QTY.
101	4210G-P	SADDLE WELD, MOR, 3PC	1
102	5933-P	HINGE CPT, CLAMP, 3PC, MOR	1
103	5933W-P	WELD, IDLER HINGE BAND, 3PC	1
104	6018-P	TOGGLE CLAMP, W/ 6" U, 5000G-P	1
105	5934-P	HINGE CPT, CATCH, 3PC, MOR	1
106	5934W-P	WELD, DRIVE HINGE BAND, 3PC	1
107	5932-P	CATCH, 341-R TOGGLE, CAMLOCK	1
108	4064-P	HHCS, 1/4-20 X 1/2 SER FLG	<b>6</b>
109	1296-P	HHCS, 1/4-20 X 7-1/2 GR5	2
110	1518-P	NUT, 1/4-20 NYLON LOCK	2



**Operator's Manual for Morse Forklift-Karrier with 3-Piece Drum Holder Model 285G**  
**Serial Number 0616 to \_\_\_\_ (MMYY)**

**Recommended Spare Parts Kit Number: RP285-03.01**

**Kit Description: Kit, Spare Parts, 285G**

Qty.	Part #	Description
1	3849B-P	BEARING BLOCK, SLIDING IDLER
2	19-P	BEARING, 3/4" ID X 2-1/2"
1	64-P	ROLL PIN, 3/16 X 1-1/4
1	5269-P	ROLL PIN, 3/16 X 1-3/4
1	5245-P	GUIDE, POCKET CHAIN WHEEL
1	1303-P	POCKET CHAIN WHEEL, 3/4 BORE
1	3-285-P	CHAIN, PULL, POCKET 20' LENGTH
1	7-P	BEARING, 3/4" ID X 1-1/2"
1	5135-P	SHAFT, 12T SPROCKET & SPACER
1	735-P	KEY, WOODRUFF, SIZE 9, ASA606
1	14-P	GEAR, PINION, 7 TOOTH
1	13-P	SPROCKET #35 36T, 3/4" BORE
1	12-P	CHAIN, ROLLER, #35 W/ M LINK
1	23-P	GEAR, SPUR, 72T, 1" HOLE
1	18-P	BEARING, 1" ID X 2-1/2"