

CONTENTS

	Page
Installation Instructions.	1 - 2
Dimensions.	2
Operating Instructions.	2 - 3
Parts Diagram.	4

Operator's Manual
for Morse

Stainless Steel Adjustable Rim Clamp Kit

Kit # 4560BSS-P

Serial number 0821 to ____ (MMYY)

INSTALLATION INSTRUCTIONS

1. Position Rim Clamp Assembly on **INSIDE** of drum holder bracket (item 1) with holes aligned
2. Bolt in place with 2 bolts (item 2) and 2 washers (item 3) using 9/16" wrench

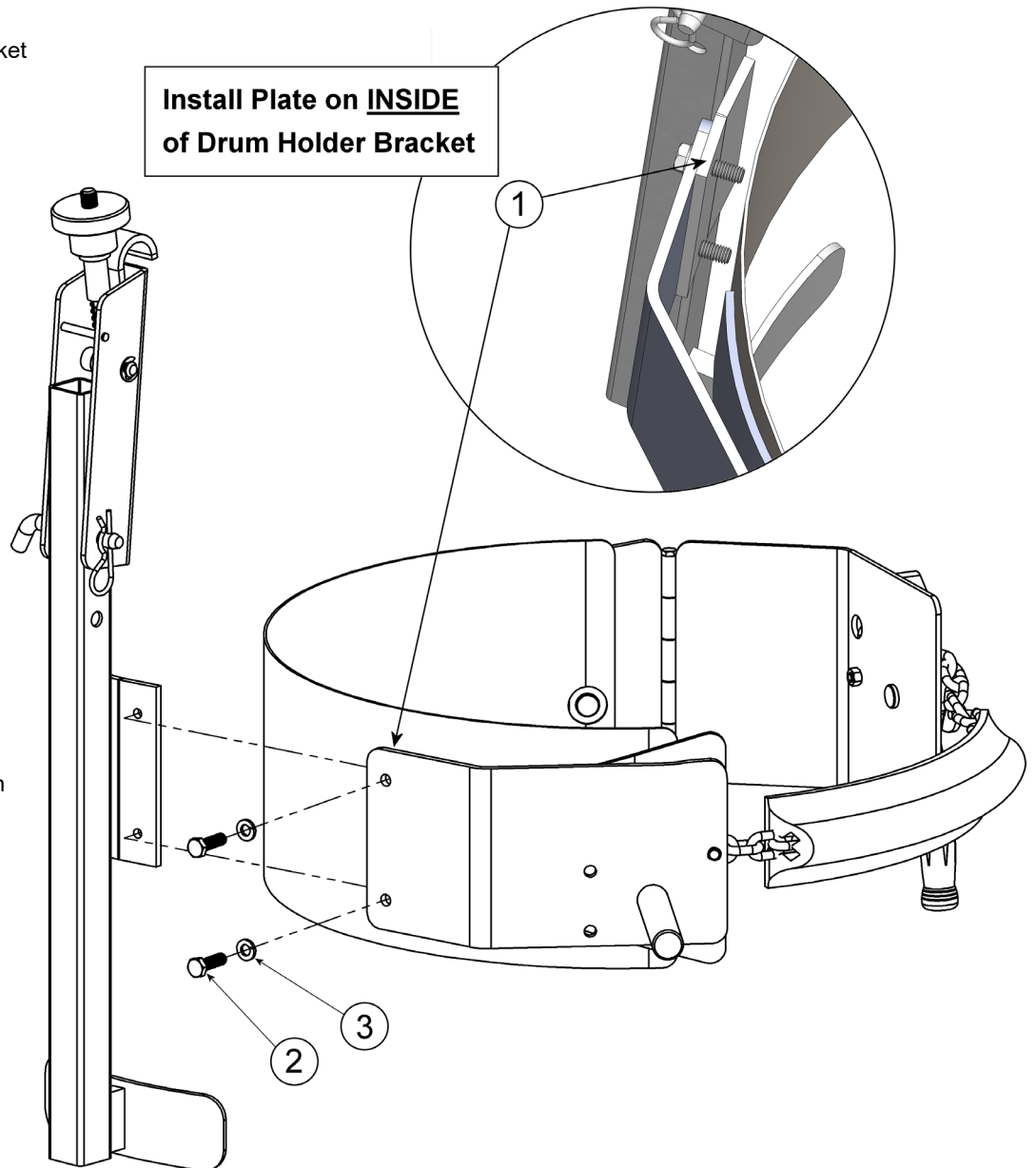

WARNING:

This product can expose you to chemicals including barium sulfate, cobalt, titanium dioxide, and 2-methylimidazole, which are known to the State of California to cause cancer, and bisphenol-A, which is known to the State of California to cause birth defects or other reproductive harm.

For more information go to www.P65Warnings.ca.gov



morsedrum.com



service@morsedrum.com



(315) 437-8475



103 Kuhn Rd.
Syracuse, NY, 13208 U.S.A.

Operator's Manual for Morse Stainless Steel Rim Clamp Assembly Kit # 4560BSS-P
Serial Number 0821 to ____ (MMYY)

DIMENSIONS

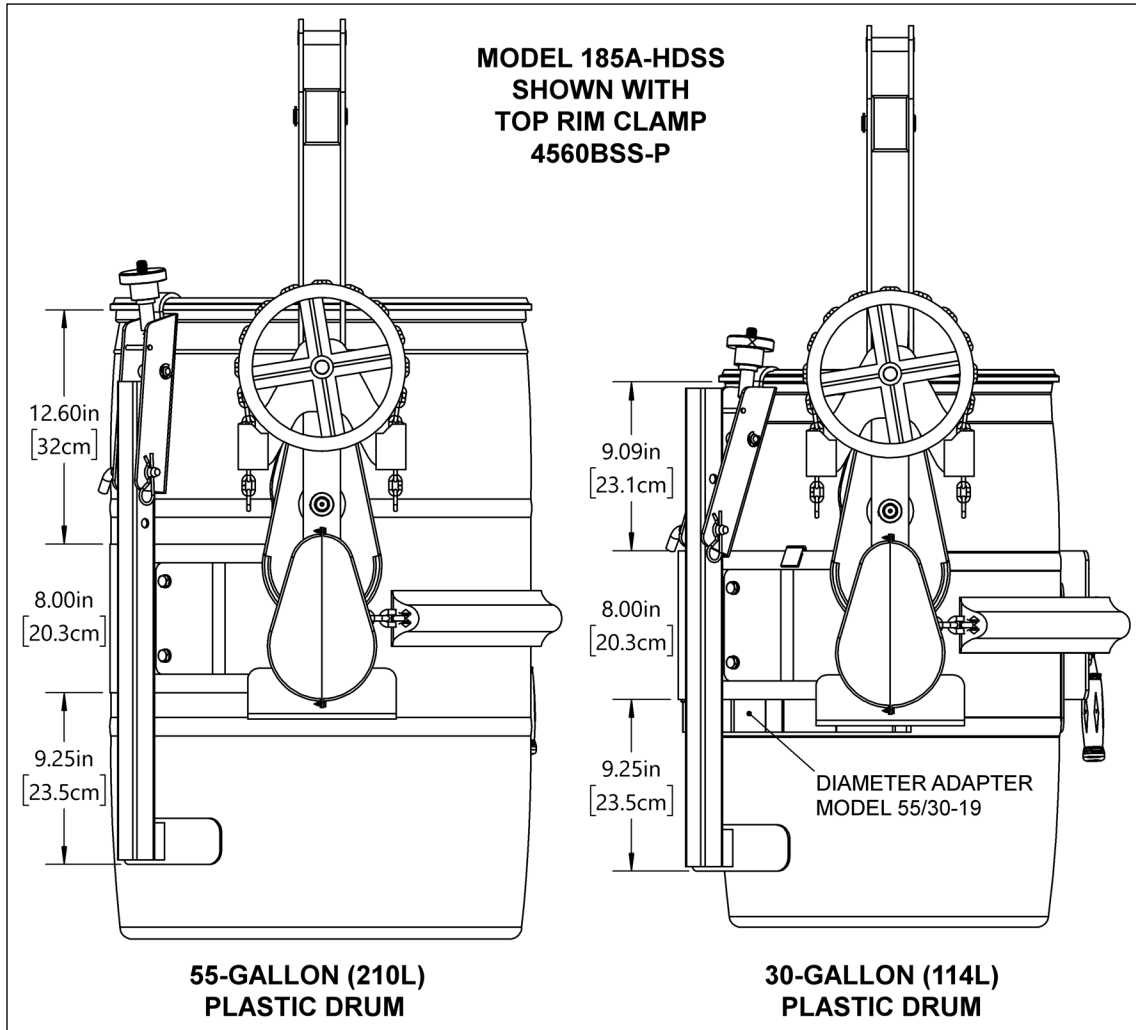

BEFORE OPERATING RIM CLAMP

**Set Correct Rim Clamp Position for
55-Gallon OR for 30-Gallon Drum
(210 Liter OR 114 Liter Drum)**

Insert pin through correct holes to set
Top Rim Clamp to position for ONE
of the following drum sizes:

1. 55-gallon (210 liter) size drum
2. 30-gallon (114 liter) size drum

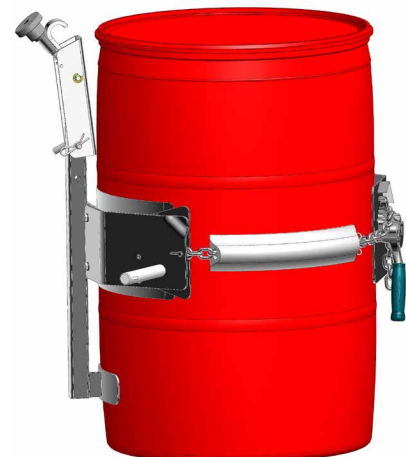

Operator's Manual for Morse Stainless Steel Rim Clamp Assembly Kit # 4560BSS-P
Serial Number 0821 to ____ (MMYY)

OPERATING INSTRUCTIONS

Steps to Secure Drum

STEP 1.

Tighten cinch chain or web strap around drum just enough to hold drum with bottom jaw of Top Rim Clamp positioned under top rim of drum.

Swing bottom jaw into position against drum sidewall to engage directly beneath drum top rim.

STEP 2.

Swing top hook over top rim of drum and turn hand wheel clockwise until SECURELY clamped over drum top rim.

STEP 3.

Securely tighten cinch chain or web strap around drum.

STEP 4.

IMPORTANT: Lift Drum SLIGHTLY... Then ensure:

1. Bottom jaw is engaged under drum top rim
2. TIGHTEN Top jaw to ensure it grips drum top rim

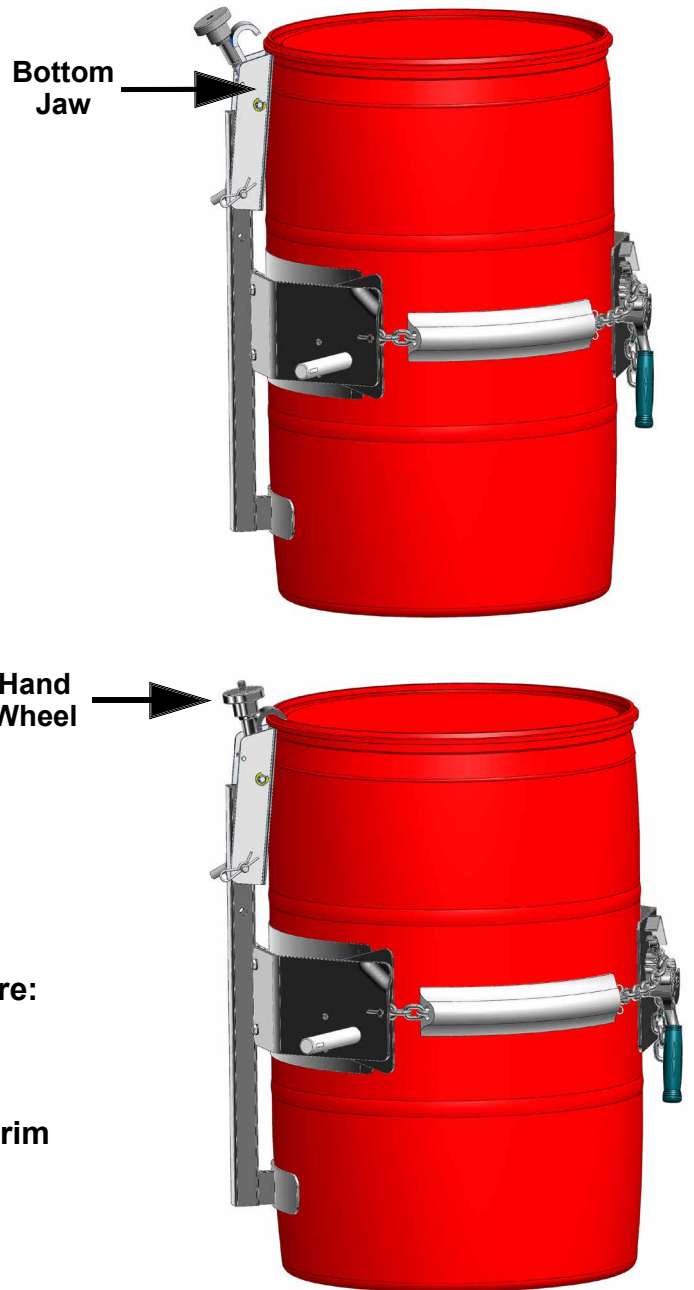

Steps to Release Drum

1. Lower drum to floor in upright position
2. Release cinch chain or web strap from around drum
3. Open Top Rim Clamp by turning knob counter clockwise
4. Disengage hook from drum top rim

Operator's Manual for Morse Stainless Steel Rim Clamp Assembly Kit # 4560BSS-P
Serial Number 0821 to ____ (MMYY)

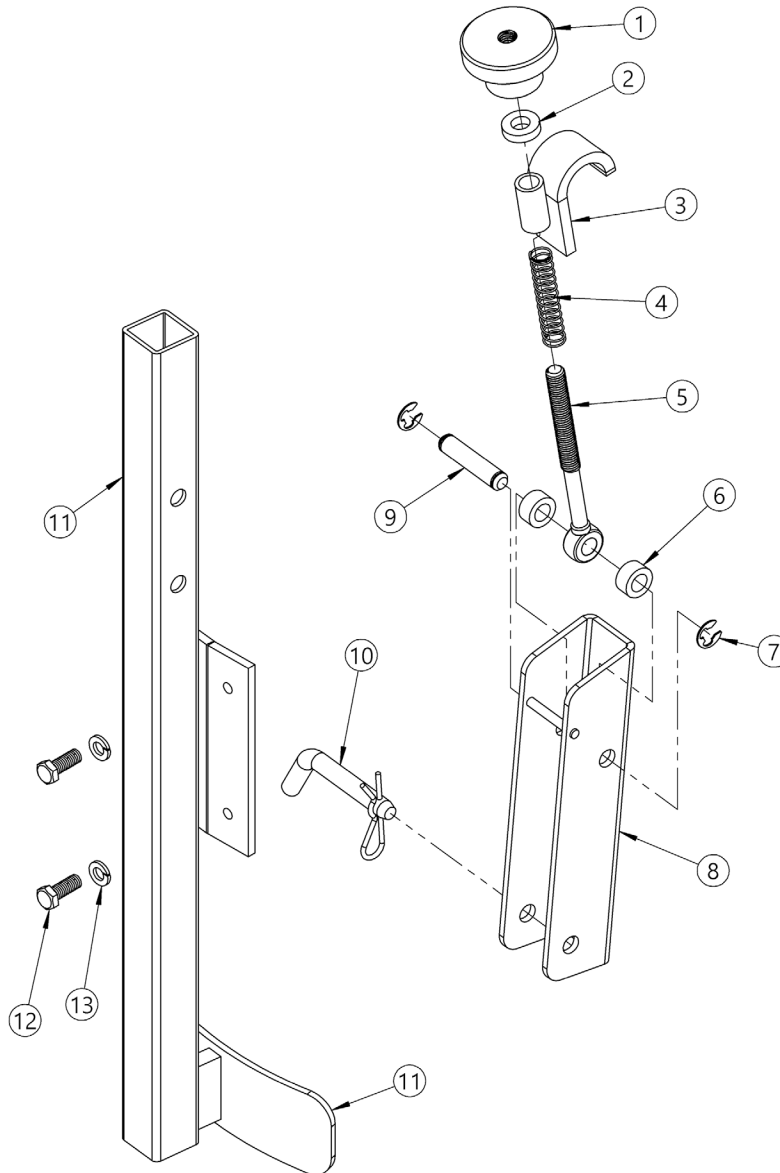

ITEM NO.	PART NUMBER	DESCRIPTION	QTY.
1	6490SS-P	KNOB, 2-1/2" DIA 1/2-13 TAP SS	1
2	6627-P	SPACER, NYLON, 1/2"OD .505"ID	1
3	6487SS-P	HOOK WELD, 4560BSS-P 4560BM-P	1
4	6590SS-P	SPRING, SS, KNOB, 4560SS-P	1
5	6484TSS-P	ROD END BOLT, TURNED 4560BSS-P	1
6	151SS-P	STOP SPACER, SS, 90-SS	2
7	3461SS-P	E CLIP, SS, 1/2", 82HM	2
8	6480BWSS-P	LOWER JAW WELD 4560BSS-P	1
9	6504SS-P	PIN, GROOVE, 1/2 X 2.080", SS	1
10	6548SS-P	PIN, QUICK, BENT, 1/2 X 3, SS	1
11	6489WSS-P	SUPPORT TUBE WELD, 4560BSS-P	1
12	535SS-P	HHCS, 3/8-16 X 1-1/4, SS	2
13	1474SS-P	WASHER, 3/8 SPLIT LOCK, SS	2