

### Parts Diagram for Morse Model 90 Verti-Karrier for 55-Gallon (210 liter) Drum Serial Number 0814 to \_\_\_\_ (MMYY)

**IMPORTANT NOTE**

4-Digit serial numbers are simply the month & year of manufacture

Example: 0802 is August 2002

For replacement parts, please contact your Morse dealer.

When ordering parts, please specify:

- Part number and description
- Model number
- Serial number

Find model number and serial number on name plate attached to frame.

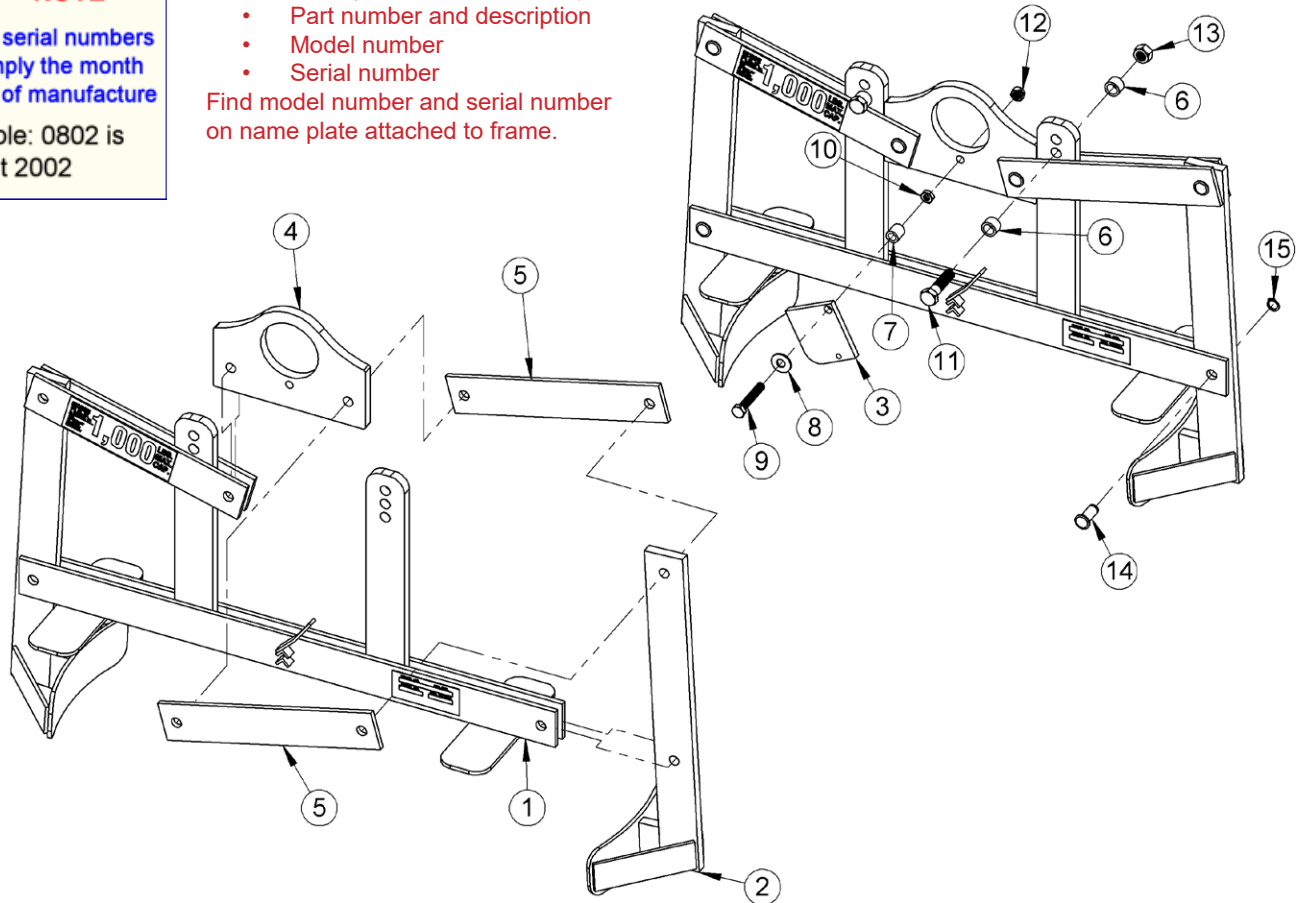

ITEM NO.	PART NUMBER	DESCRIPTION	Default/QTY.
1	144-P	BASE WELD, 90	1
2	143-P	ARM WELD, 90	2
3	145-P	LATCH WEIGHT WELD, 90	1
4	980-P	LIFTING PLATE, B/O, DRILLED 90	1
5	985-P	LINK, 90, 6/88	4
6	151-P	STOP SPACER, 90	4
7	1968-P	TUBING, 5/8 OD X .688, 90, 155	1
8	1166-P	WASHER, 3/8 USS 1" OD	1
9	6242-P	HHCS, 3/8-16 X 2-1/4 FULL THRD	1
10	1165-P	3/8 - 16 JAM NUT	1
11	1168-P	1/2 - 13 X 2 HHCS GR 2	2
12	3981-P	NUT, 3/8-16 NYLON LOCK	1
13	91-P	NUT, 1/2-13 FIN HEX	2
14	5344-P	PIN, GROOVE, 1/2 X 1.0625 C	6
15	5345-P	SNAP RING, EXT, HD, .05, 1/2"	6