

Super-Duty Kontrol-KARRIER

MADE
IN
USA

- 2500 Lb. Capacity
- Hand operated geared tilt
- 360° drum tilt control in both directions
- Quick, sure below hook drum handling by one person
- Save time, reduce waste, improve productivity
- Efficient, controlled high level pouring

Morse manual drum tilt Kontrol-KARRIER

Model 185XGR has a pull chain and chain wheel for manual drum tilt control with a 20' loop of chain to reach 10' back to the forklift operator. There is enough resistance in the enclosed gear box to automatically stop and hold the drum tilt angle. Hand wheel tilt control option is also available.

Extra-heavy-duty construction with steel tube framework, large shafts and bearings offer long life in tough service. The oil filled, worm gear speed reducer provides 150:1 gear reduction for fine control when tipping heavy drums.

The 3-Piece Drum Holder with 2 hinged metal bands and a clamp in the front is sized for your standard ribbed 55-gallon 22.5" diameter steel drum.

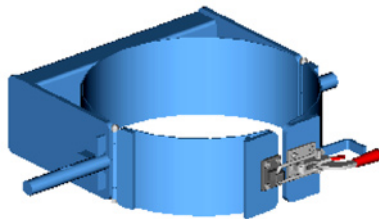

Ships fully assembled.

Full Drum Capacity 2500 Lb. Half-full drum capacity is 1250 Lb. Half-full rating is an indication of capacity for tilting an unbalanced, bottom-heavy drum. A partially full drum with unbalanced and shifting load is harder to tilt than full drum.

Dimensions

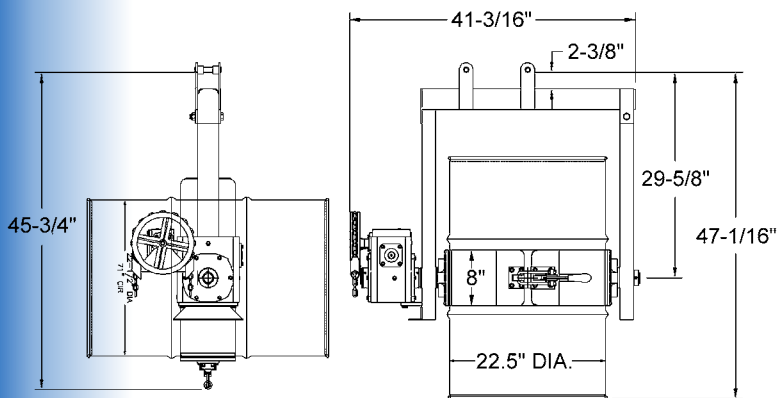

NOTE: Standard loop of pull chain extends approximately 6 feet below the chain wheel. Custom lengths are available.



Steps for use of Model 185XGR Kontrol-KARRIER

1. Attach to your hoist hook using off-center lifting point so empty Kontrol-KARRIER will hang plumb. Lift and move the Kontrol-KARRIER to your upright drum.
2. Mate the Kontrol-KARRIER's drum holder to the middle of your drum and secure your drum between drum ribs... no tools are needed.
3. Place the hoist hook in the lifting point above the drum center to lift Kontrol-KARRIER with your secured drum.
4. Pull down one side of the chain loop while letting out the other to turn your drum. Chain loop provides control of drum tilt 360° in either direction, even while drum is hoisted above your reach.

Options and Accessories

- **Option X03-185XGR** - 10" Hand Wheel with speed handle. Replaces the standard chain wheel with hand wheel to turn the drum.
- **Model 55/30-19GR** Diameter Adaptor. Simply insert this Diameter Adaptor into the drum holder to use model 185XGR for your 19" diameter 30-gallon steel drum. Quickly and easily install this Diameter Adaptor in the drum holder. Then simply lift it back out to go back to handling a 55-gallon steel drum.



Model #	Description	19" Diameter Adaptor	Unit Weight	Ship Weight	Ship Dimensions	Ships Class
185XGR	Kontrol-KARRIER with 3-piece drum holder, 2500 Lb. Capacity	Model 55/30-19GR	273 Lb.	300 Lb.	L 45" W 24" H 40"	77.5

MORSE Mfg. Co., Inc. • 727 West Manlius St. • P.O. Box 518 • East Syracuse, NY 13057-0518
Phone: (315) 437-8475 • Fax: (315) 437-1029

Email: nicepeople@MORSEmfgco.com • Website: www.MORSEmfgco.com