

Extra Heavy-Duty Forklift-Karrier

Extra Heavy-Duty Forklift-Karrier - 2,000 Lb. (907 kg) Capacity

MADE
IN
USA

- 360° drum tilt control in both directions
- Hand operated geared tilt with fully enclosed gear box
- Quick, sure drum handling with your forklift
- Save time, reduce waste, improve productivity
- Controlled high-level pouring

Manual drum tilt is controlled with a 20' (6 m) pull chain loop hanging 10' (3 m) below the chain wheel. There is enough resistance in the enclosed gear box to automatically stop and hold the drum tilt angle. Hand wheel tilt control option is also available.

Extra-heavy-duty construction with steel tube framework, large shafts and bearings offer long life in tough service. An oil filled, worm gear speed reducer provides 150:1 gear reduction for fine control when tipping heavy drums.

Full Drum Capacity 2,000 Lb. (907 kg), Half-full* drum capacity 1,000 Lb. (454 kg).

The drum holder of Model 285A-GR has an 8" wide metal band with chains and two load binders to secure your 22.5" (57.15 cm) diameter steel drum.



Dimensions

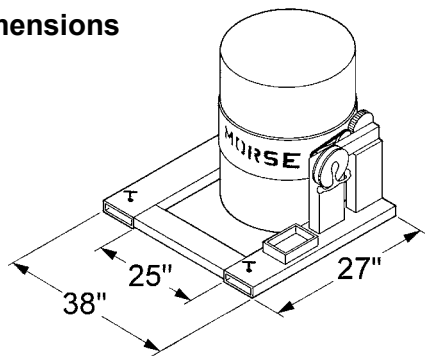

Fork pocket openings are 6.5" wide x 2.5" high (16.5 x 6.35 cm). Fork pockets are 26.5" (67.3 cm) deep.

Inside width between forks must be at least 25" (63.5 cm).

Ship Dimensions: L 45" W 33" H 23" (114 x 84 x 58 cm). Class 70.

NOTE: Standard loop of pull chain extends approximately ten feet beyond the chain wheel. Custom lengths are available.

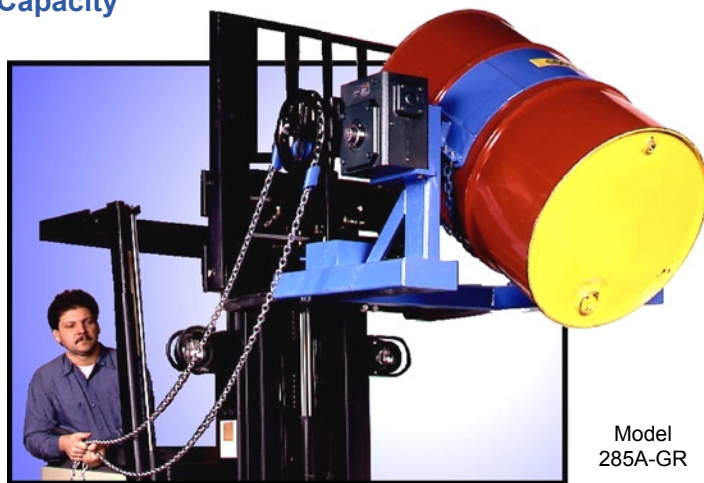

Model
285A-GR

Steps to use Extra Heavy-Duty Forklift-Karriers

1. Drive your truck forks into the Extra Heavy-Duty Forklift-Karrier's fork pockets, then dismount and screw down safety locks to grip the forks.
2. Drive to a drum at ground level, so that the drum holder meets the center of your drum.
3. Secure your drum in the drum holder between drum ribs... no tools are needed.
4. Raise your forklift carriage and the secured drum, then travel to the dumping location.
5. To turn the drum without leaving your forklift seat, pull the chain loop for complete control of drum tilting.
6. Lower drum to the floor, then release load binders.
7. Loosen screw down safety locks, then back forks out of fork pockets.

Options and Accessories

- **Option X03-285GR** - 10" (25.4 cm) Hand Wheel with speed handle. Replaces the standard chain wheel with hand wheel to turn the drum.
- **Model 55/30-19GR** Diameter Adaptor. Simply insert this Diameter Adaptor into the drum holder to handle your 19" (48.3 cm) diameter 30-gallon (114 liter) steel drum. Remove the Adaptor to handle your 55-gallon (208 liter) steel drum. Quickly and easily install this Diameter Adaptor in the drum holder. Simply lift it back out to handle a 55-gallon steel drum.



* Half-full rating is an indication of capacity for tilting an unbalanced, bottom-heavy drum. A partially full drum with unbalanced and shifting load is harder to tilt than a full drum.

Model #	Description	19" Adaptor	Unit Weight	Ship Weight
285A-GR	Extra-Heavy-Duty Forklift-Karrier, drum holder with load binders	55/30-19GR	244 Lb. (111 kg)	273 Lb. (124 kg)