

Lift and Dispense a Drum with Your Forklift

Forklift-Karrier with 3-Piece Drum Holder - 800 Lb. (363 kg) Capacity

- Quickly mount on your forklift
 - No tools or truck modifications
 - No electric or hydraulic connections
- Provides controlled drum pouring
- Allows 360° drum tilt control in both directions
- Eliminates backbreaking labor and dangerous, makeshift methods
- Custom versions available

Morse Forklift-Karriers have a 20' (6 m) long pull chain loop with 10' (3 m) drop so you control drum tilting, 360° in either direction. Dispense a drum right from your forklift. Can also be ordered with Hand Crank or Hand Wheel option for use only within reach.

We recommend the MORStop Tilt-Brake option to automatically hold the drum tilt angle until you move it. This prevents a partially full, unbalanced drum from turning out of control, even when the contents shift from one end to the other.

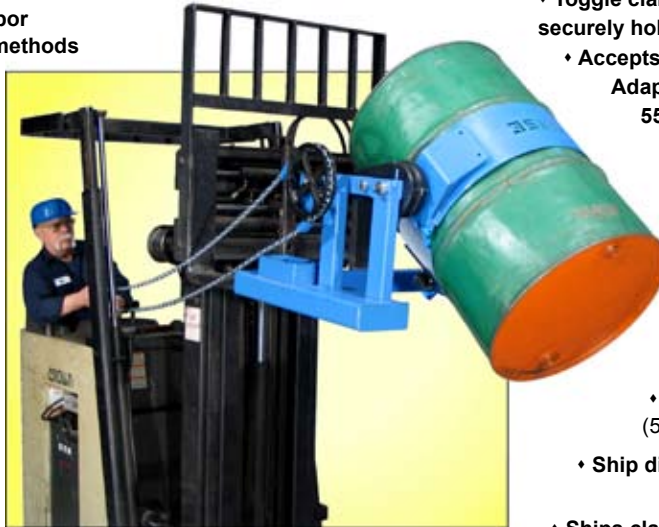

3-Piece Drum Holder

- Sized for ribbed 55-gallon (208 liter) steel drum with 22.5" (57 cm) diameter
- Hinged metal bands surround drum
- Toggle clamp closure securely holds drum



• Accepts Diameter Adaptor Model

55/30-19GR for 18.5" to 19" (47 to 48.25 cm) diameter drum

- Has durable stress relief weld joints

Model 285G

- Has chain wheel controlled tilt with 30:1 gear ratio and safety cover
- Handle drum with faucet or valve in place
- Has 800 Lb. (363 kg) full-drum capacity (500 Lb. (227 kg) half-full* drum capacity).
- Ship dimensions: L 42" W 34" H 23" (107 x 87 x 59 cm)
- Ships class 70

MODEL #	FORKLIFT-KARRIER DESCRIPTION	ADAPTOR FOR 30-GALLON DRUM	SHIP WEIGHT
285G	Handle ribbed 55-gallon (208 liter) steel drum	55/30-19GR	162 Lb. (73.5 kg)

* Half-full rating is an indication of capacity for tilting an unbalanced, bottom-heavy drum. A partially full drum with unbalanced and shifting load is harder to tilt than a full drum.

Options

Bracket Assembly



The **Bracket Assembly** provides a brace at top and bottom of your drum to prevent it from slipping lengthways through the drum holder. Use it to handle a smooth sided 55-gallon steel drum that lacks ribs. The bracket adjusts for 31" to 39" (79 to 99 cm) tall drum.

Part # 4556-P Bracket Assembly

Part # 4556M-P Spark Resistant Bracket Assembly

Part # 4556SS-P Stainless Steel Bracket Assembly

Top Rim Clamp



The **Top Rim Clamp** grips the upper rim of your drum to prevent it from slipping through the drum holder. Use it to handle a smooth sided 55-gallon (208 liter) steel drum that lacks ribs.

Part # 4560-P Top Rim Clamp Assembly

Part # 4560M-P Spark Resistant Top Rim Clamp Assembly

Part # 4560SS-P Stainless Steel Top Rim Clamp Assembly

Diameter Adaptor



Diameter Adaptor inserts into the drum holder to handle a typical 30-gallon (114 liter) drum with 18.5" to 19" (47 to 48.25 cm) diameter.

Model 55/30-19GR Diameter Adaptor for 30-gallon drum.

Tilt Control Options



Option # 3900i-P MORStop Tilt-Brake factory installed on your Forklift-Karrier is recommended to automatically hold the drum tilt angle.

Part # 3900-P MORStop Tilt-Brake Kit for field installation.

Option X01-285 Hand Crank with MORStop Tilt-Brake.



Option X02-285 Hand Crank.

Option X03-285 16" (40.6 cm) Hand Wheel.

Operating Instructions

1. Before sliding forklift forks into the fork tubes, adjust forks to an inside spread of 25" (63.5 cm) minimum. Lock forks into position on the forklift carriage.
2. Drive the forklift forward to slip the forks into the fork tubes. Tighten tee screws to secure the Forklift Karrier to the forks.
3. Pull the linch pin, open the toggle clamp and swing both hinged bands to the open position. Push Kontrol-Karrier against drum so that saddle will encircle drum.
4. Drive the forklift with the Forklift Karrier near floor level to position the saddle band around the middle of the drum between the ribs.
5. Secure the drum: Close the two hinged bands around the drum, latch the toggle clamp and insert the linch pin (see detail A).
6. Remove pull chain from chain box on base frame and place end of loop near operator's seat.
7. Raise forks to clear the floor and transport drum in vertical position to dispensing location.
8. To pour drum: pull on chain, rotating drum to angle required for dispensing. To control the pouring angle of the drum, pay out one side of chain and pull the other side to prevent the drum from free-wheeling.
9. If the Forklift-Karrier is equipped with the MORStop Tilt-Brake, there is no need to hold tension on both sides of the chain loop. Braking is immediate and self-actuating, without additional steps by the operator. To add the MORStop Tilt-Brake to your Forklift-Karrier, order kit for field installation (part # 3900-P).
10. When dispensing is completed, rotate the drum back to vertical and return drum. While transporting, ensure that the drum is raised away from the floor to prevent the drum bottom from interfering with a pallet or other obstacle.

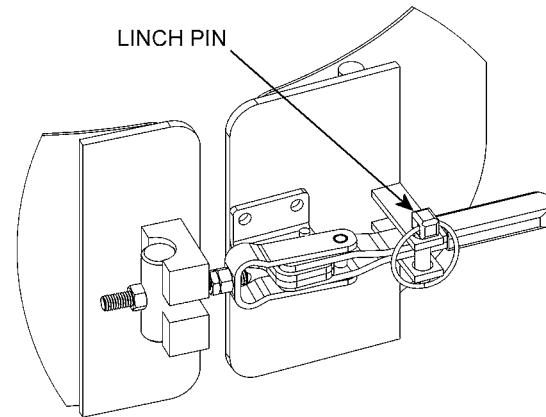
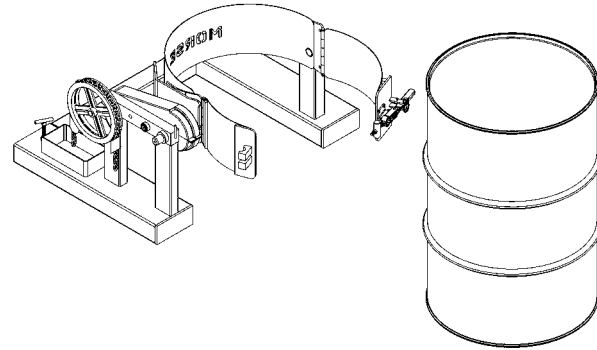

Detail A

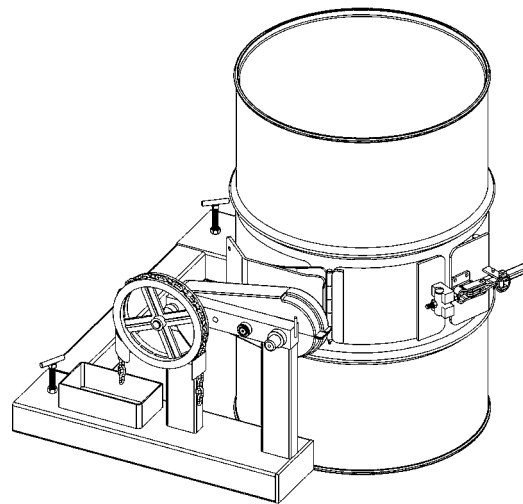

Dimensions

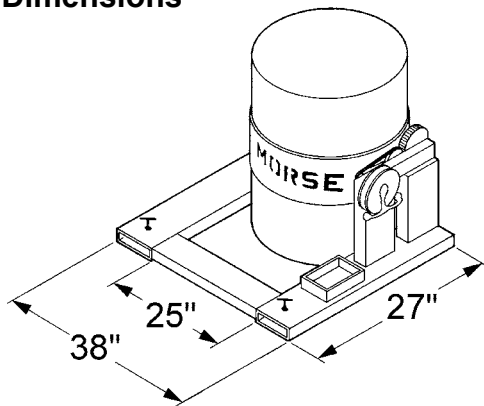

Fork pocket openings are 6.5" wide x 2.5" high (16.5 x 6.35 cm).

Fork pockets are 26.5" deep (67.3 cm).

Inside width between forks must be at least 25" (63.5 cm).

NOTE: Standard loop of pull chain extends approximately 10' (3 m) beyond the chain wheel. Custom lengths are available.

Please contact your Morse dealer