

CONTENTS

	Page
Receiving Procedures.	1
Warranty.	1
Safety Information.	1 - 2
Machine Description.	3 - 4
Operating Instructions.	5
Maintenance.	6

Operator's Manual
for Morse Vertical-Lift MORSPEED™
Model 512-125

Serial Number 275611 to _____

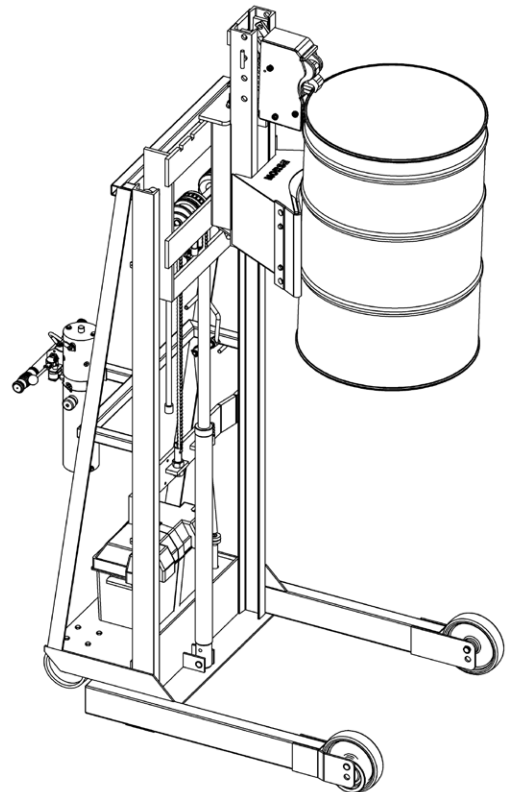

Receiving Procedures

Every Morse drum handler is inspected prior to shipping. However, damage may be incurred during transit.

- Check for visible damage. If you choose to accept damaged freight, always sign noting the damage on the **Bill of Lading**.
- Document the damage and have the truck driver sign. We recommend keeping a digital camera at your receiving dock for this purpose.
- Open packages expeditiously to check the condition of the goods. There is only a 24 hour window to notify the carrier of any concealed damage.
- Immediately **report all damage to the shipping company!** Then you may contact Morse for assistance with your freight claim.
- Morse Manufacturing will not be held responsible for any damaged freight that is not signed for as damaged.

Limited 2 Year Warranty

Morse drum handling equipment is guaranteed against defects in workmanship or materials for two years when used properly within its rated capacity. Warranty does not cover wear from normal use or damage from accident or abuse. Motors and other purchased parts carry the warranties of their manufacturers.

For warranty claims, contact your Morse Dealer to obtain a return authorization number, and for return freight advice. Return freight must be prepaid.

In all instances, liability is limited to the purchase price paid or to repairing or replacing the product. Customer assumes liability for any modifications, unauthorized repairs or parts substitution.

Safety Information

While Morse Manufacturing Co. drum handling equipment is engineered for safety and efficiency, a high degree of responsibility must be placed upon the machine operator to follow safe practices, based primarily on common sense, upon which true safety depends.



Failure to follow the safety precautions in this manual can result in personal injury or property damage. Observe the same precautions as with similar machinery where carelessness in operating or maintenance is hazardous to personnel. Carefully read the safety precautions below and throughout this manual.

Review the Material Safety Data Sheet(s) for the material(s) in the drum(s) and take all necessary precautions. Safety shoes, work gloves, hard hat and other personal protective devices are recommended.

Prior to initial use, inspect all moving parts. Perform necessary load test, inspections, operator training, etc.

Operator's Manual for Morse Vertical-Lift MORSPEED™ Model 512-125
Serial Number 275611 to _____

Safety Information (continued)

	DANGER - Indicates a situation which, if not avoided, <i>will</i> result in serious injury or death. This signal word is limited to the most extreme situations.
	WARNING - Indicates a situation which, if not avoided, <i>could</i> result in serious injury or death.
	CAUTION - Indicates a situation which, if not avoided, can result in damage to the machine.



CAUTION - Do NOT transport with drum raised.
Always lower the drum holder to lowest position before transporting.



DANGER - Stay well clear of power lines.
Never approach a power line. Current in a high voltage line may arc some distance from the wire to the steel framed, grounded machine.



WARNING - The Vertical-Lift MORSPEED™ is designed to handle one drum of the types listed at the top of page 3 - Machine Description. DO NOT attempt to handle any other type of drum or object. DO NOT exceed the weight capacity of 800 Lb. (363 kg).



WARNING - Level floors only.
For operation only on clean, level floors of suitable bearing capacity. Do not use on sloped surfaces, ramps, irregular or debris strewn floors.



WARNING - Do NOT modify the unit.
Under no circumstances should any modifications be made to the Morse machinery without factory authorization. Any modifications may void the warranty. This machine was designed to perform a specific job and alterations may result in injury to operator or machine.



WARNING - No loose fitting clothing.
Wear close-fitting clothing and safety equipment appropriate to the job. Loose fitting clothing may become caught on the machinery and cause severe personal injury.



WARNING - Hydraulic fluid under pressure can be hazardous.
Escaping hydraulic fluid under pressure can penetrate the skin, causing serious injury. Avoid the hazard by relieving pressure before disconnecting hydraulic lines. Keep hands and body away from pinholes and nozzles, which eject fluid under high pressure. Use a piece of cardboard to search for leaks. If an accident occurs, see a doctor immediately and inform them of the nature of the accident.



CAUTION - Wear safety shoes.
Wear safety shoes with non-slip soles and hard toe protection.



WARNING: This product can expose you to chemicals including barium sulfate, cobalt, titanium dioxide, and 2-methylimidazole, which are known to the State of California to cause cancer, and bisphenol-A, which is known to the State of California to cause birth defects or other reproductive harm.
For more information go to www.P65Warnings.ca.gov



WARNING: This product can expose you to chemicals including lead and arsenic, which are known to the State of California to cause cancer and birth defects or other reproductive harm.
For more information go to www.P65Warnings.ca.gov

Operator's Manual for Morse Vertical-Lift MORSPEED™ Model 512-125
Serial Number 275611 to _____

Machine Description

The Model 512-125 Vertical-Lift MORSPEED™ will lift a drum up to 45" (114 cm) high, measured from the floor to the lowest point of a vertical drum. It is designed to lift and transport a rimmed drum.

Lift and transport:

- Rimmed steel, fiber or plastic drum
- Maximum capacity is 800 Lb. (363 kg)
- Requires a minimum of 75 Lb. (34 kg) to begin the gripping action
- Drum height must be 24" (61 cm) or taller
- Works with any diameter drum
- Can be used with a straight walled or damaged drum

MORSE
Mfg. Co., Inc.
E. Syracuse, NY

The
Specialist
In Drum
Handling
Equipment

800
(363 kg)

Lb.
Max.
Capacity

Made in U.S.A.

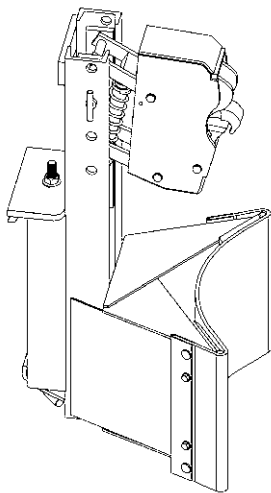

Option

Kit # 2523-P Belted Backrest Pad equips MORSPEED™ with a 12" (30.5 cm) wide fabric belt. It contacts the side of your drum to help protect it from being marred in handling. It is available as a bolt-on accessory.

Machine Unpacking

Inspect the machine for visible damage. If damage is noted, follow receiving procedure on page 1.

Remove machine from pallet by lifting from the square tubing at the top of the unit. Insert a strap or chain through the tubing and make a loop to lift by. Attach loop to an overhead crane and raise slowly.

Operator's Manual for Morse Vertical-Lift MORSPEED™ Model 512-125
Serial Number 275611 to _____

Installation Instructions

Machine is shipped with hydraulic fluid.

BEFORE operation, replace the **RED** shipping plug from the hydraulic reservoir with the **BLACK** breather, and insert lever handle into pump socket.

Battery has been charged prior to shipping and should be ready for use. See battery charger spec sheet.

Controls

The Morse Vertical-Lift **MORSPEED™** is manually propelled and steered. The drum lift is powered by a 12V DC motor.

There is one function for the operator to control: "LIFT" and lower function for vertical positioning of the drum.

LIFT and Lower Function (Figure 3.1)

- Push and hold the valve handle in against the start switch.
- Release the handle when the drum is at the desired height.
- To lower the drum: Pull and hold the valve handle out away from the start switch.

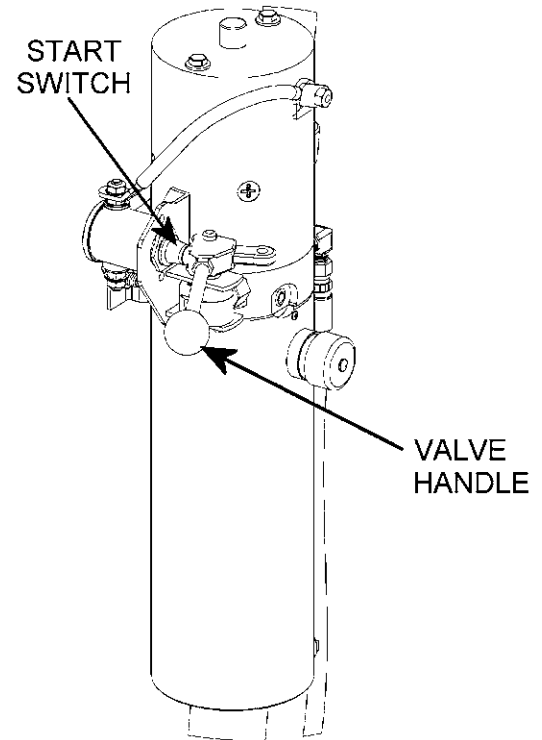

Figure 3.1



WARNING - Watch out for pinch points

Stay clear of moving parts. Operator should remain behind the push handle during the lift operation.

Floor Lock

The floor lock handle is located on the left side of the push handle. Pulling the floor lock handle toward the operator until it locks in the down position activates the floor lock. When the floor lock is activated it prevents unwanted free wheeling of the unit. Floor conditions determine the effectiveness of the floor lock. The operator should verify its holding action before depending on it to hold.

Drum Holder Assembly

The **MORSPEED™** drum holder assembly is the component on the Vertical-Lift **MORSPEED™** that is intended to hold the drum. The carriage assembly moves vertically along the mast, to position the **MORSPEED™** drum holder assembly designed to secure a drum by gripping the top rim.

Operator's Manual for Morse Vertical-Lift MORSPEED™ Model 512-125
Serial Number 275611 to _____

Operating Instructions

1. Push the Vertical-Lift MORSPEED™ to the drum.
2. Using the "LIFT" control as described in "Machine Description - Controls" (page 4), position the top of the MORSPEED™ head so it is flush with the top of the drum. MORSPEED™ jaws must arrive below the rim of the drum. If necessary, lower the MORSPEED™ head before contacting the drum to assure jaws will be below drum rim before attempting to lift drum.
3. **Attaching the drum:** Push MORSPEED™ head against drum. The spring loaded parallel links will pivot downward to cushion against the drum. Spring pressure will tend to keep the head forward, in contact with the drum during lifting to assure the lower jaw catches the underside of the drum top rim during the lift.
4. Operate the lift function to lift drum clear of floor. Push unit to deliver drum where needed. NOTE: Do not allow the drum to impact on floor, etc. or a spill or damage could occur.



WARNING: Once drum is correctly picked-up, it should remain held safely by the MORSPEED™ unless the unit is driven fast over a bad ridge or wide crack in the ground. The sudden movement could momentarily unweight the drum, thus allowing the jaws to open. Therefore, discipline should be followed by keeping the load low when moving from place to place, and by avoiding unreasonable surfaces and speeds.

5. Lift drum to desired height.



CAUTION – Do NOT transport with drum raised.

ALWAYS LOWER THE DRUM HOLDER TO LOWEST POSITION BEFORE TRANSPORTING. The unit can become unstable when transporting with a raised load.



WARNING - Stay clear of raised drum

NEVER allow anyone to be below any part of a raised drum handler or drum. Remain behind the push handle while handling a drum.

6. To release drum, simply lower drum until the MORSPEED™ jaws open automatically when weight is removed. Do NOT stop lowering as soon as drum touches down. Keep going down for a few inches more. Then you can back away.
7. Push the unit to storage area with MORSPEED™ fully lowered.

TIP # 1 - For 55-gallon steel drums, set MORSPEED™ Heads in carriage mount so that cross-pin is in the top or second hole. For shorter drums use suitable lower holes. It is always best to keep Vee Backrest as close to the bottom of the drum as possible.

TIP # 2 - It is not necessary to have the jaws make first contact with the drum rim. Simply drive them in below the rim and raise. They will engage as the lower jaws catch under the rim as the MORSPEED™ rises.

Possible Reasons for Failure to Pick Up Drum

- Unit being allowed to creep backwards after contact with drum has been made.

Possible Reasons for Failure to Release Drum

- Procedure in paragraph 6 of Operating Instructions not being followed.

Operator's Manual for Morse Vertical-Lift *MORSPEED*[™] Model 512-125
Serial Number 275611 to _____

Maintenance

1. Periodic inspection for the general condition of structural and mechanical components is imperative for safe and efficient operation.
2. Periodically inspect all moving parts, framework, drum holder and contact areas for signs of wear, fatigue, or loosening. Tighten, adjust, or replace parts as necessary to prevent failure and maintain proper function.
3. Inspect the hydraulic system for oil drips, hose damage, or other signs of wear. Inspect the level of the hydraulic fluid. Replace any parts that show signs of wear.
4. Grease wheel bearings periodically. Oil or grease all moving part. The *MORSPEED*[™] head should be protected from the weather when not in use. Apply 90W oil generously to all moving joints and spring anchor points approximately every 500 drum lifting cycles.
5. Worn or damaged parts must be properly replaced with the correct, genuine Morse parts.
6. Hydraulic pump is shipped filled with Noco Premium plus automatic transmission fluid d/m. Material safety data sheet (MSDS) is available online. Change oil yearly, sooner depending on dirty conditions or outdoor use. Replace oil with Mobil dte 24 or equivalent for indoor use (Mobil dte 13 for outdoor use).