

**Morse part # 1-5-1 Idler Attachment
to roll a 1 to 5 gallon can on Morse Drum Roller**

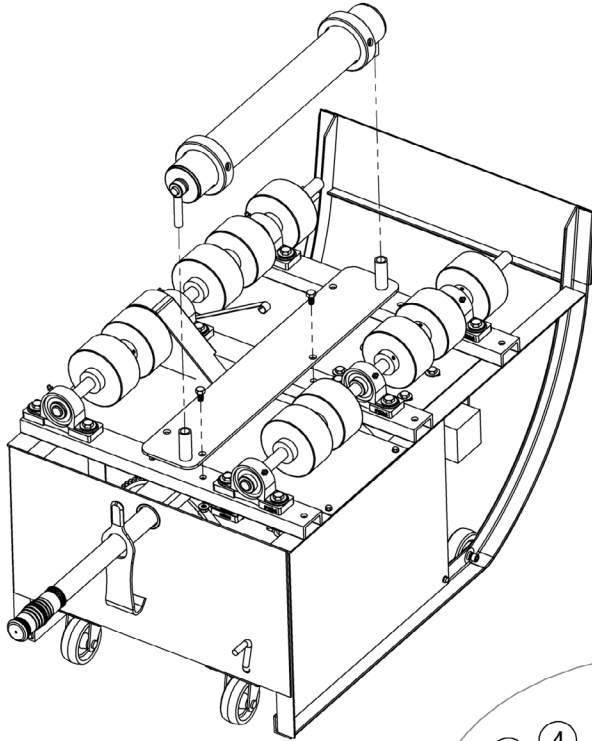

Assembly Instructions

1. Fasten base (item 1) onto the rotator channel as shown in diagram. Use the two bolts (item 7) and whiz-lock nuts (item 8) provided.
2. With the roller tube (item 2), collars (item 3), roller axle (item 4), tube bearing (item 5), and roller holder (item 6) assembled as shown, slide both roller holders (item 6) directly inside each roller base tube. Tighten down both collars on roller holders (item 6).
3. Adjust large collars (item 3) on the roller tube (item 2) far enough apart so that the can rolls between them.
4. Adjust the drive wheels on the rotator to roll the can.

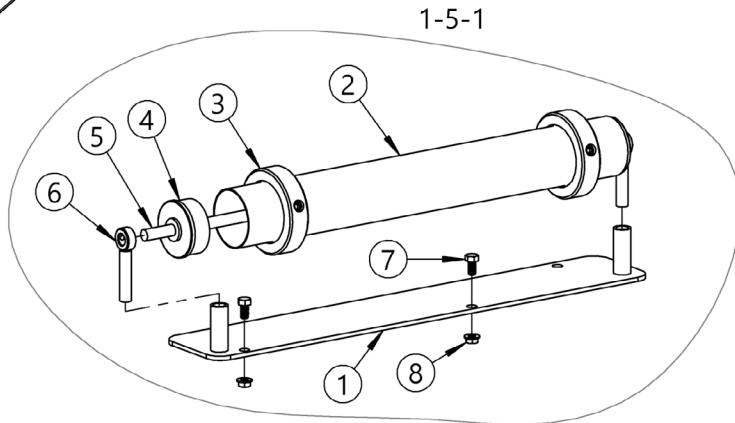

ITEM NO.	PART NUMBER	DESCRIPTION	QTY.
1	6290W-P	BASE WELD, 1-5-1	1
2	1197-P	ROLLER TUBE, 1-5 GAL IDLER	1
3	1195-P	COLLAR, 2-9/16" ID, 1-5 GAL	2
4	1906-P	TUBE BRG, 1/2" BORE	2
5	1199-P	ROLLER AXLE, 1-5 GAL IDLER	1
6	1200-P	ROLLER HOLDER, WELD, 1-5	2
7	1572-P	HHCS, 3/8-16 X 1 GR2 ZINC	2
8	4002-P	NUT, 3/8-16 WHIZ LOCK	2

