

**Parts Diagram for DC Power Lift Components
Used on Morse Model 410-125 Heavy-Duty Hydra-Lift Karrier
with 6-digit serial number 400000 to _____
with 4-digit serial number 1210 to ____ (MMYY)**

**IMPORTANT
NOTE**

4-Digit serial numbers
are simply the month
& year of manufacture
Example: 0802 is
August 2002

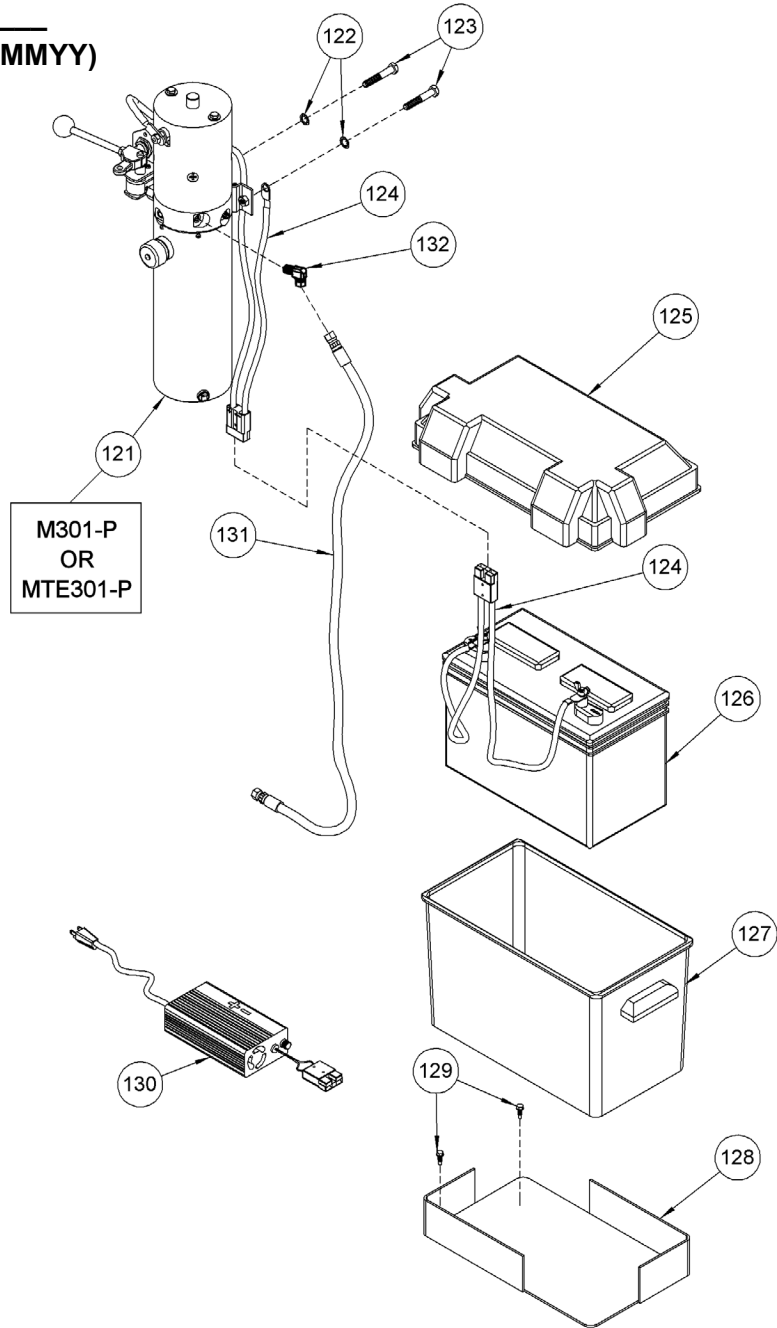

ITEM	QTY.	PART #	DESCRIPTION
121	1	M301-P (SHOWN)	HYD POWER PACK, -125
121	1	MTE301-P	HYD POWER PACK, -125 MTE
122	2	1739-P	WASHER 3/8 INTERNAL TOOTH LOCK
123	2	82-P	HHCS, 3/8-16 X 2-1/4 GR2
124	2	404-P	HARNESS, PUMP CABLE, 20/20
125	1	1728-P	TOP, BATTERY BOX, 400, 285A-BP

ITEM	QTY.	PART #	DESCRIPTION
126	1	388-P	BATTERY, 12V DC
127	1	1729-P	BOTTOM, BATTERY BOX, 400
128	1	1726W-P	WELD, BATTERY MOUNT, 410 DC
129	2	193-P	SCREW, 12-14 X 3/4 3 PT TEK
130	1	391-P	CHARGER 12V 50HZ 60HZ 100-240V
131	1	5180-P	HYD HOSE ASM, 28"
132	1	765-P	HYD FIT, MALE ELBOW, FLARE 400