

Parts List and Diagram for Model 155 Drum Hand Truck
Manufactured 01/2018 to _____

1. Slide the Handle Assembly tube through the Hook Slide Weldment (item 25) and into the Base Assembly tube and align drilled holes.
2. Insert bolt (item 21) through the aligned holes and secure with Lock Nut (item 22) to fasten the Handle Assembly to the Base Assembly.

Note: Hook Slide Weldment slides freely on the Handle Assembly tube to engage the upper rim of your drum.

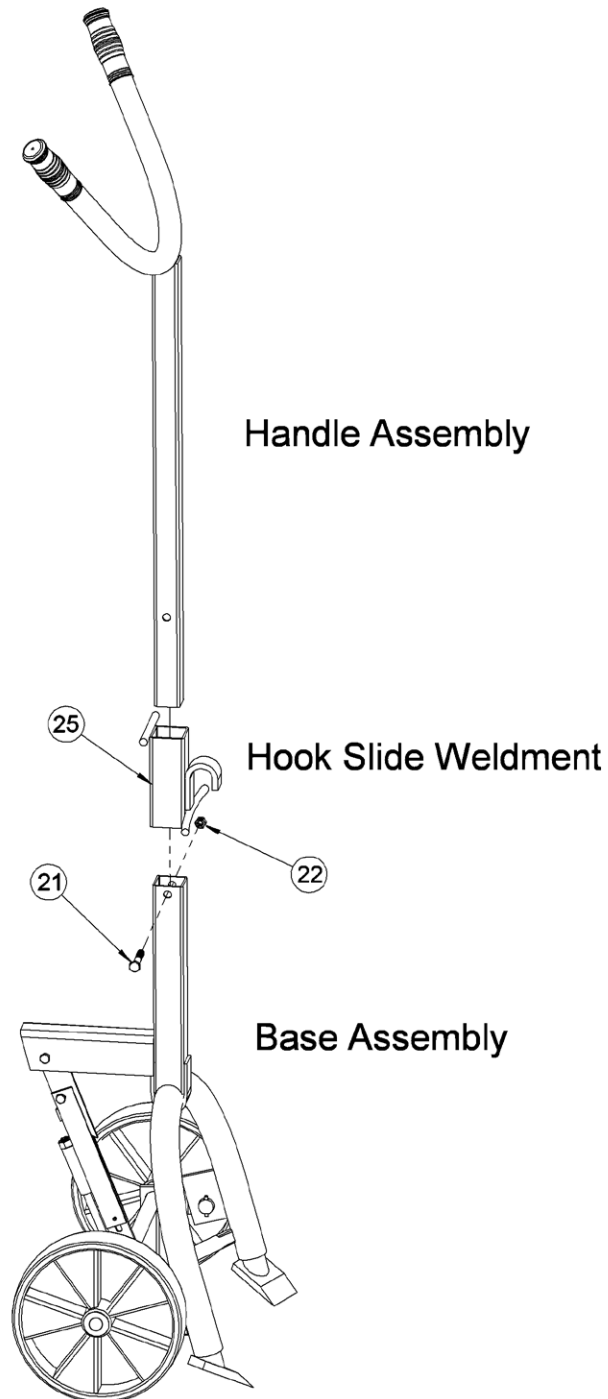

WARNING: This product can expose you to chemicals including barium sulfate, cobalt, titanium dioxide, and 2-methylimidazole, which are known to the State of California to cause cancer, and bisphenol-A, which is known to the State of California to cause birth defects or other reproductive harm. For more information go to www.P65Warnings.ca.gov



morsedrum.com



service@morsedrum.com



(315) 437-8475



103 Kuhn Rd.
Syracuse, NY 13208 U.S.A.

Parts List and Diagram for Model 155 Drum Hand Truck Manufactured 01/2018 to _____

For replacement parts, please contact your Morse dealer.

When ordering parts, please specify:

- Part number and description
- Model number

Find model number and serial number on metal name plate attached to frame.

Morse Model 155			
ITEM	QTY	PART #	DESCRIPTION
1	1	3972-P	BASE WELD, 155
2	1	1969-P	AXLE WELD, 155
3	2	1971-P	PEG WELD, 155
7	1	1962-P	BEVEL LINK, 155
8	1	1970-P	STAND WELD, 155
9	2	1968-P	TUBING, 5/8 OD X .688 90 155
10	1	35-P	HHCS, 5/16-18 X 1 GR2
11	2	491-P	NUT, 5/16-18 REV HEX LOCK
12	2	64-P	ROLL PIN, 3/16 X 1-1/4
13	1	176-P	ROLL PIN, 3/16 X 3/4
14	1	3970-P	HANDLE WELD, 152, 153, 155
15 *	2	702-P	WHEEL, RUBBER, 10", 7/8" BORE
17 *	4	1850-P	COLLAR, 7/8" ID, 201B
18	1	1954-P	HHCS, 5/16-18 X 2-1/2 GR2
19	1	1110-P	SPRING, COMPRESSION, 155
20	1	1007-P	SET SCREW, 1/2-13 X 3/4 CUP
21	1	82-P	HHCS, 3/8-16 X 2-1/4 GR2
22	1	1169-P	NUT, 3/8-16 REV HEX LOCK
23	2	83-P	GRIP, HANDLE, 1-1/4 X 4-1/2
25	1	1947-P	HOOK SLIDE WELD, 152

* Recommended spare parts.

