

**Contents**

	Page
Receiving Procedures. . . . .	1
Warranty. . . . .	1
Safety Information. . . . .	1 - 2
Machine Description. . . . .	3
Operating Instructions. . . . .	4
Maintenance. . . . .	4
Parts List and Diagram. . . . .	5 - 6
Recommended Spare Parts. . . . .	7

**Operator's Manual**  
**for Morse Adjusto-Karrier**

**Model 184**  
**Serial number 1109 to \_\_\_\_ (MMYY)**

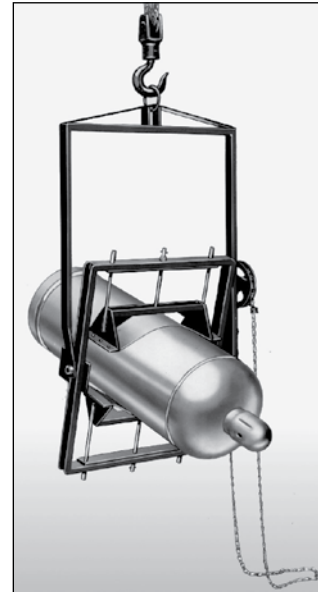

**Receiving Procedures**

Every Morse drum handler is inspected prior to shipping. However, damage may be incurred during transit.

- Check for visible damage. If you choose to accept damaged freight, always sign noting the damage on the **Bill of Lading**.
- Document the damage and have the truck driver sign. We recommend keeping a digital camera at your receiving dock for this purpose.
- Open packages expeditiously to check the condition of the goods. There is only a 24 hour window to notify the carrier of any concealed damage.
- Immediately **report all damage to the shipping company!** Then you may contact Morse for assistance with your freight claim.
- Morse Manufacturing will not be held responsible for any damaged freight that is not signed for as damaged.

**Limited 2 Year Warranty**

Morse drum handling equipment is guaranteed against defects in workmanship or materials for two years when used properly within its rated capacity. Warranty does not cover wear from normal use or damage from accident or abuse. Motors and other purchased parts carry the warranties of their manufacturers.

For warranty claims, contact your Morse Dealer to obtain a return authorization number, and for return freight advice. Return freight must be prepaid.

In all instances, liability is limited to the purchase price paid or to repairing or replacing the product. Customer assumes liability for any modifications, unauthorized repairs or parts substitution.

**Safety Information**

While Morse Manufacturing Co. drum handling equipment is engineered for safety and efficiency, a high degree of responsibility must be placed upon the machine operator to follow safe practices, based primarily on common sense, upon which true safety depends.

Failure to follow the safety precautions in this manual can result in personal injury or property damage. Observe the same precautions as with similar machinery where carelessness in operating or maintenance is hazardous to personnel. Carefully read the safety precautions below and throughout this manual.

Review the Material Safety Data Sheet(s) for the material(s) in the drum(s) and take all necessary precautions. Safety shoes, work gloves, hard hat and other personal protective devices are recommended.

Prior to initial use, inspect all moving parts and test rotation of chain wheel and drum holder assembly. Inspect drum holder assembly for proper operation. Perform necessary load test, inspections, operator training, etc.

### Operator's Manual for Morse Model 184 Adjusto-Karrier Serial number 1109 to \_\_\_\_ (MMYY)

#### Safety Information (continued)



**DANGER** - Indicates a situation which, if not avoided, will result in serious injury or death. This signal word is limited to the most extreme situations.



**WARNING** - Indicates a situation which, if not avoided, could result in serious injury or death.



**CAUTION** - Indicates a situation which, if not avoided, can result in damage to the machine.



**WARNING** - Adjusto-Karriers are designed to handle one drum of the types listed at the top of page 3. Machine Description. DO NOT attempt to handle any other type of drum or object.



**WARNING** - DO NOT exceed the weight capacity of 500 Lb. (227 kg).



**WARNING** - DO NOT operate damaged or malfunctioning unit, or a unit with missing parts.



**WARNING** - DO NOT lift people or suspend loads over people. Stay clear of suspended loads.



**WARNING** - DO NOT lift loads higher than necessary.



**WARNING** - DO NOT leave suspended loads unattended.



**WARNING** - DO NOT remove or obscure warning labels.



**WARNING** - DO NOT operate without first having read and understood operating manual.



**WARNING** - DO NOT make alterations or modify the unit. Under no circumstances should any modifications be made to the Morse machinery without factory authorization. Any modifications may void the warranty. This machine was designed to perform a specific job and alterations may result in injury to operator or machine.



**WARNING** - Wear safety shoes with non-slip soles and hard toe protection.



**CAUTION:** DO NOT allow drum to impact on floor, ground, etc.

**Operator's Manual for Morse Model 184 Adjusto-Karrier**  
Serial number 1109 to \_\_\_\_ (MMYY)

**Machine Description**

The Model 184 Adjusto-Karrier is designed to lift, transport, and dispense a steel or fiber drum 8" to 15" (20.3 to 38.1 cm) in diameter. The maximum full-drum capacity is 500 Lb. (227 kg). The capacity is derated to 250 Lb. (114 kg) for a half-full drum. The half-full rating is based on the tilt mechanism's capacity for handling an unbalanced bottom-heavy drum.



**Options**

- Option X01-186 Hand Crank with MORStop Tilt-Brake factory installed on new model 184.  
To replace standard chain wheel tilt control with this option in the field, order kit # 1460-P and kit # 3900-P.
- Option X02-186 Simple Hand Crank factory installed on new model 184.  
To replace standard chain wheel tilt control with this option in the field, order kit # 1460-P.
- Option X03-186 16" (40.6 cm) Diameter Hand Wheel factory installed on new model 184.  
To replace standard chain wheel tilt control with this option in the field, order Kit # 2690-P.

**Important**

1. Review the Material Safety Data Sheet(s) for the material(s) in the drum(s) and take all necessary precautions. Safety shoes, work gloves, hard hat and other personal protective devices are recommended.
2. Please read all instructions *thoroughly* before attempting to operate your new MORSE drum handler.
3. These models have a maximum capacity rating of 500 Lb. (227 kg) full drum and 250 Lb. (114 kg) half-full drum. The 184 is designed to lift, move and pour 8" to 15" (20.3 to 38.1 cm) diameter steel and fibre drums. *DO NOT* exceed these ratings. Exceeding these ratings or handling drums other than those mentioned above is unsafe and could result in equipment damage, excessive wear or awkward handling.
4. When loading, unloading, operating, or maintaining your MORSE drum handler, always use care and good judgment. Maintain secure footing and a firm hold. Keep hands and loose clothing away from all moving parts. Never allow anyone to be below any part of a raised drum handler or drum. Read operating instructions and review the pictures in the sales brochure before operation.
5. Model 184 is "Group 1 - Structural and Mechanical" Below-the-Hook Lifting Device which is covered by the American National Standard ANSI/ASME B30.20. The user should comply with all aspects of this standard.

**Assembly Instrucions**

1. Remove chain wheel (item 1), guide (item 2), pull chain (item 3) and roll pin (ietm 6) from carton.
2. Place guide over shaft (item 7). Align hole in chain wheel with hole in shaft. Hammer roll pin through aligned holes. If roll pin doesn't clear easily, rotate chain wheel 180° and try opposite side.
3. Place chain in chain wheel.
4. Prior to initial use, inspect all moving parts and test rotation of chain wheel and saddle assembly.
5. Perform necessary load test, inspections, operator training, etc. as prescribed in the ANSI/ASME B30.20 standard.

**Operator's Manual for Morse Model 184 Adjusto-Karrier**  
**Serial number 1109 to \_\_\_\_ (MMYY)**

**Operating Instructions**

1. With Adjusto-Karrier standing on the floor, lower hoist and engage hoist hook into the lifting eye.
2. Raise hoist to lift Adjusto-Karrier clear of floor and move it to the drum.
3. Back off each adjusting screw (item 33) using the removeable hand crank (item 34).
4. Position Adjusto-Karrier over drum.
5. Lower until Saddle Assembly (item 22) is aligned with the center of the load.
6. Turn each adjusting screw to tighten the binder strap (item 26) so drum is centered in the saddle assembly.
7. Raise hoist and position drum at the pouring station.
8. Pour drum by pulling on the pull chain (item 3) and rotating the drum to a suitable pouring angle.
9. After pouring is completed, rotate drum to vertical and lower hoist to return drum to floor.
10. Remove drum by backing out one adjusting screw and raising hoist to lift Adjusto-Karrier clear of drum.

**Maintenance**

Periodic inspection for the general condition of structural and mechanical components is imperative for safe and efficient operation.

1. Lubricate gear teeth and roller chain.
2. Clean and oil ratchet, pawl and other moving parts periodically. Clean and lubricate more often in environments where dust, dirt or other foreign particles will effect the performance of moving parts.
3. Periodically inspect all moving parts, framework, drum holder and contact areas for signs of wear, fatigue, or loosening. Tighten, adjust, or replace parts as necessary to prevent failure and maintain proper function.
4. Worn or damaged parts must be properly replaced with the correct, genuine Morse parts.

**Operator's Manual for Morse Model 184 Adjusto-Karrier**  
Serial number 1109 to \_\_\_\_ (MMYY)

ITEM	QTY.	PART #	DESCRIPTION
1 *	1	1303-P	POCKET CHAIN WHEEL, 3/4 BORE
2	1	1304-P	GUIDE, POCKET CHAIN WHEEL
3 *	1	3-185-P	PULL CHAIN, POCKET, 12' LENGTH
4 *	1	19-P	BEARING, 3/4" ID X 2-1/2"
5	1	1411-P	SPACER, SHAFT W/ 12T SPROCKET
6	4	64-P	ROLL PIN, 3/16 X 1-1/4
7 *	1	1302-P	SHAFT W/ 12T SPROCKET, POCKET
8	1	15-P	COLLAR, 3/4" ID
9 *	1	7-P	BEARING, 3/4" ID X 1-1/2"
10	1	16-P	COLLAR, 1" ID
11 *	1	18-P	BEARING, 1" ID X 2-1/2"
12 *	1	12-P	CHAIN, ROLLER, #35 W/ M LINK
13	1	795-P	LINK, MASTER, #35 CHAIN
14 *	1	13-P	SPROCKET #35 36T, 3/4" BORE
15 *	1	14-P	GEAR, PINION, 7 TOOTH
16 *	1	735-P	KEY, WOODRUFF, SIZE 9, ASA606
17	1	29-P	SPACER, SPUR GEAR .15"
18	2	22-P	SHCS, 3/8-24 X 5/8
19 *	1	23-P	GEAR, SPUR, 72T, 1" HOLE
20	1	42-184-P	OVERHEAD LIFT YOKE 184 W/ BRG
21	1	62-P	WASHER, 3/4 SPRING
22	1	1018-184-P	SADDLE ASM, 184
23	1	1019-P	FRAME, SADDLE, 184
24	16	35-P	HHCS, 5/16-18 X 1 GR2
25	4	179-P	CLAMP PLATE, 184, 186
26	2	181-184-P	BINDER STRAP, 184
27	2	182-184-P	BINDER FRAME, 184
28	16	491-P	NUT, 5/16-18 REV HEX LOCK
29	2	173-P	WASHER, 1/2 SAE FL 1-1/16 OD
30	2	174-P	THRUST BEARING
31	2	1000-P	SET SCREW, 1/4 - 20 X 1/4
32	2	2314-P	NUT, 5/8 ACME HEX, W/ HOLE 186
33	2	178-P	SCREW, 5/8 - 8 ACME, 186
34	1	183-P	HAND CRANK ASM, 186
35	1	4062-P	KIT, POLY COVER, 185, 285, 400 (NOT SHOWN)
* Recommended spare parts			

Operator's Manual for Morse Model 184 Adjusto-Karrier  
Serial number 1109 to \_\_\_\_ (MMYY)

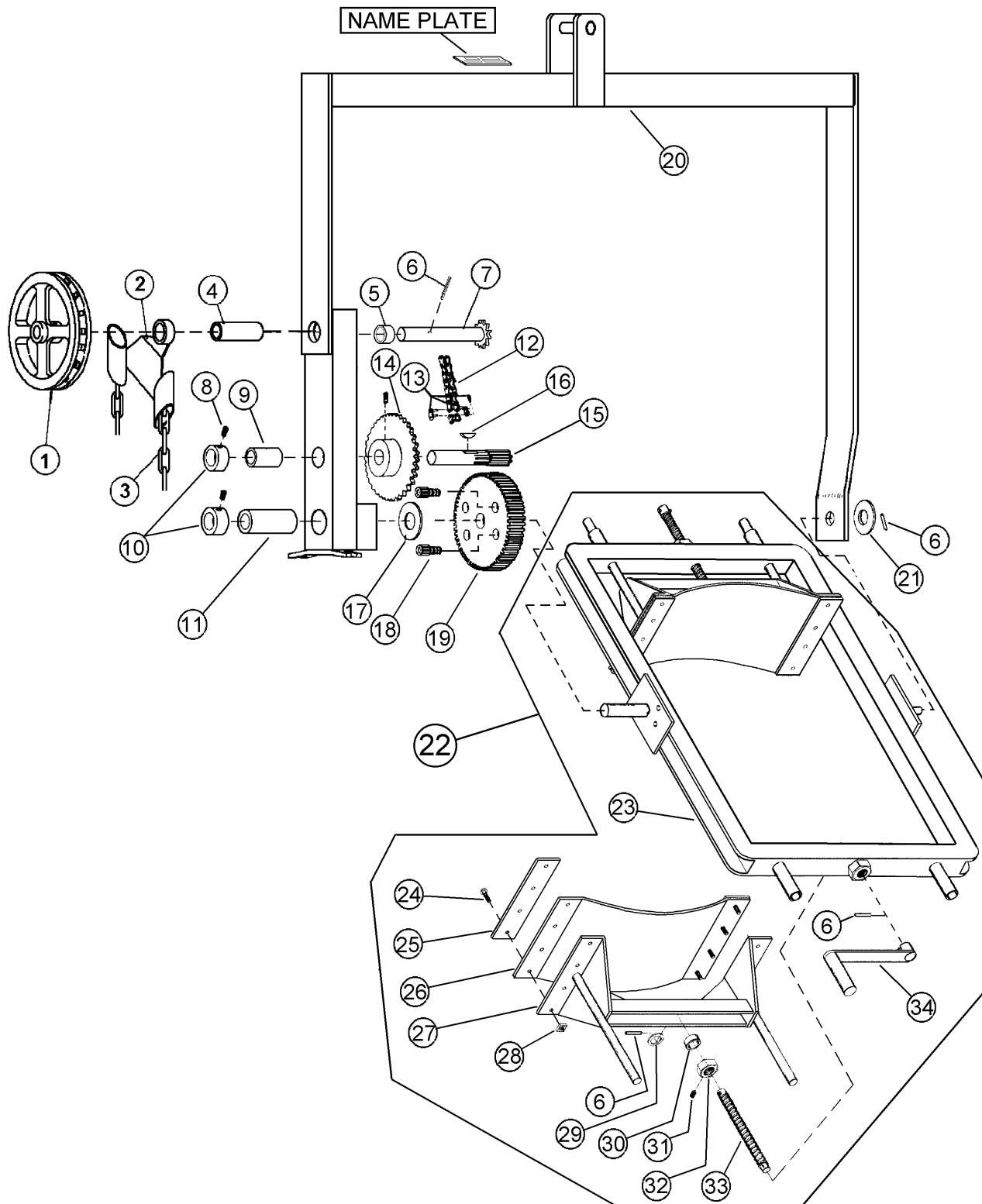

**Operator's Manual for Morse Model 184 Adjusto-Karrier**  
**Serial number 1109 to \_\_\_\_ (MMYY)**

**Recommended Spare Parts Kit Number: RP184-01**

**Kit Description: Kit, Spare Parts, 184**

Qty.	Part #	Description
1	1303-P	POCKET CHAIN WHEEL, 3/4 BORE
1	3-185-P	CHAIN, PULL, POCKET 12' LENGTH
1	19-P	BEARING, 3/4" ID X 2-1/2"
1	1302-P	SHAFT W/ 12T SPROCKET, POCKET
1	7-P	BEARING, 3/4" ID X 1-1/2"
1	18-P	BEARING, 1" ID X 2-1/2"
1	12-P	CHAIN, ROLLER, #35 W/ M LINK
1	13-P	SPROCKET #35 36T, 3/4" BORE
1	14-P	GEAR, PINION, 7 TOOTH
1	735-P	KEY, WOODRUFF, SIZE 9, ASA606
1	23-P	GEAR, SPUR, 72T, 1" HOLE