

Contents

	Page
Receiving Procedures.	1
Warranty.	1
Safety Information.	1 - 2
Machine Description.	3
Operating Instructions.	3
Maintenance.	3
Parts List and Diagram.	4

Operator's Manual
for Morse Kontrol-Karriers
Model 185A

Serial number 0103 to ____ (MMYY)

Receiving Procedures

Every Morse drum handler is inspected prior to shipping. However, damage may be incurred during transit.

- Check for visible damage. If you choose to accept damaged freight, always sign noting the damage on the **Bill of Lading**.
- Document the damage and have the truck driver sign. We recommend keeping a digital camera at your receiving dock for this purpose.
- Open packages expeditiously to check the condition of the goods. There is only a 24 hour window to notify the carrier of any concealed damage.
- Immediately **report all damage to the shipping company!** Then you may contact Morse for assistance with your freight claim.
- Morse Manufacturing will not be held responsible for any damaged freight that is not signed for as damaged.

Limited 2 Year Warranty

Morse drum handling equipment is guaranteed against defects in workmanship or materials for two years when used properly within its rated capacity. Warranty does not cover wear from normal use or damage from accident or abuse. Motors and other purchased parts carry the warranties of their manufacturers.

For warranty claims, contact your Morse Dealer to obtain a return authorization number, and for return freight advice. Return freight must be prepaid.

In all instances, liability is limited to the purchase price paid or to repairing or replacing the product. Customer assumes liability for any modifications, unauthorized repairs or parts substitution.



Safety Information

While Morse Manufacturing Co. drum handling equipment is engineered for safety and efficiency, a high degree of responsibility must be placed upon the machine operator to follow safe practices, based primarily on common sense, upon which true safety depends.

Failure to follow the safety precautions in this manual can result in personal injury or property damage. Observe the same precautions as with similar machinery where carelessness in operating or maintenance is hazardous to personnel. Carefully read the safety precautions below and throughout this manual.

Review the Material Safety Data Sheet(s) for the material(s) in the drum(s) and take all necessary precautions. Safety shoes, work gloves, hard hat and other personal protective devices are recommended.

Prior to initial use, inspect all moving parts. Perform necessary load test, inspections, operator training, etc.

Operator's Manual for Morse Model 185A Kontrol-Karrier Serial number 0103 to ____ (MMYY)

Safety Information (continued)



DANGER - Indicates a situation which, if not avoided, will result in serious injury or death. This signal word is limited to the most extreme situations.



WARNING - Indicates a situation which, if not avoided, could result in serious injury or death.



CAUTION - Indicates a situation which, if not avoided, can result in damage to the machine.



WARNING - Kontrol-Karriers are designed to handle one drum of the types listed at the top of page 3. Machine Description. DO NOT attempt to handle any other type of drum or object.



WARNING - DO NOT exceed the weight capacity of 800 Lb.



WARNING - DO NOT operate damaged or malfunctioning unit, or a unit with missing parts.



WARNING - DO NOT lift people or suspend loads over people. Stay clear of suspended loads.



WARNING - DO NOT lift loads higher than necessary.



WARNING - DO NOT leave suspended loads unattended.



WARNING - DO NOT remove or obscure warning labels.



WARNING - DO NOT operate without first having read and understood operating manual.



WARNING - DO NOT make alterations or modify the unit. Under no circumstances should any modifications be made to the Morse machinery without factory authorization. Any modifications may void the warranty. This machine was designed to perform a specific job and alterations may result in injury to operator or machine.



WARNING - Wear safety shoes with non-slip soles and hard toe protection.



CAUTION: DO NOT allow drum to impact on floor, ground, etc.

Operator's Manual for Morse Model 185A Kontrol-Karrier
Serial number 0103 to ____ (MMYY)

Machine Description

Model 185A Kontrol-Karrier is designed to lift, transport and dispense a standard 55-gallon steel drum 22.5" in diameter. The maximum capacity is 800 Lb.

Important

1. Review the Material Safety Data Sheet(s) for the material(s) in the drum(s) and take all necessary precautions. Safety shoes, work gloves, hard hat and other personal protective devices are recommended.
2. Please read all instructions thoroughly before attempting to operate your new Morse drum handler.
3. The 185 Series Kontrol-Karriers have a maximum capacity rating of 800 Lb. for a FULL drum and 500 Lb. for a HALF-FULL drum, and are designed to lift and move a drum of the size and type noted above. DO NOT exceed this rating. Exceeding this rating or handling drums other than those mentioned above is unsafe and could result in equipment damage, excessive wear, awkward or dangerous handling.
4. When loading, unloading, operating, or maintaining your MORSE drum handler, always use care and good judgment. Maintain secure footing and a firm hold. Keep hands and loose clothing away from all moving parts. Never allow anyone to be below any part of a raised drum handler or drum. Read operating instructions and review the pictures in the sales brochure before operation.
5. The 185 Series are a "Group 1 structural and mechanical" below-the-hook lifting device which are covered by the American National Standard ASME B30.20. The user should comply with all aspects of this standard.



Operating Instructions

1. Start with Kontrol-Karrier on the floor. Lower hoist and engage hoist hook to lift Kontrol-Karrier.
2. Raise hoist to lift Kontrol-Karrier clear of floor and transport it to the drum.
3. Suspend Kontrol-Karrier at a height which aligns drum saddle with center of drum.
4. With binder chain (item 25) hanging freely, push Kontrol-Karrier against drum so that saddle will encircle drum.
5. Secure the drum: drape the binder chain (item 25) across the face of the drum and engage a link into the slot in the ratchet (item 32). Turn the ratchet clockwise to tighten chain. If the chain doesn't cinch tightly on the drum, lift the pawl (item 30) to loosen and release the chain and try again with a different link in the notch. Firm hand pressure on the ratchet handle should tighten the chain sufficiently to hold the drum. DO NOT use mechanical aids such as a pipe to extend handle for extra leverage.
6. Raise hoist and position drum at pouring station.
7. Pour the drum by pulling on the pull chain (item 3) and rotating the drum to a suitable pouring angle. For best control of drum pouring angle, pay out one side of the chain loop while pulling in the other side, thus being able to hold back the drum rotation. The chain lock on the bottom of the power arm can be used to prevent drum rotation. To do so, criss cross the chain and insert in each slot of the chain lock. If the drum handler is equipped with the MORStop Tilt-Brake, there is no need to hold tension on both sides of the chain loop. Braking is immediate and self actuating, without additional steps by the operator. To add the MORStop Tilt-Brake to your drum handler, order part # 3900-P for a field installation kit.
8. After pouring is completed, rotate drum back to vertical position and lower hoist to return drum to floor.
9. To remove drum: Pull ratchet handle clockwise to relieve pressure on ratchet teeth. Lift pawl handle (item 30) to release teeth engagement and rotate ratchet to loosen chain and allow its removal from notch.

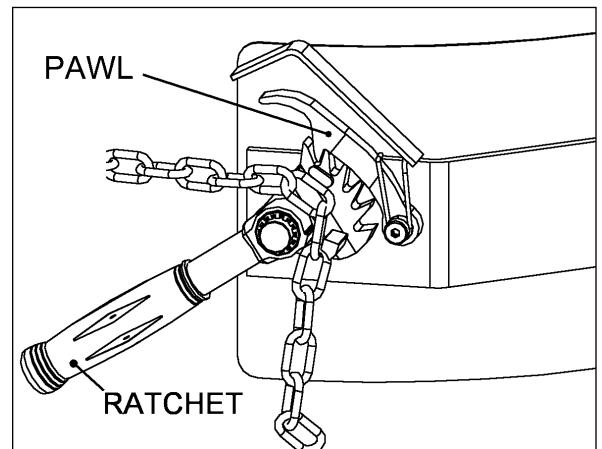

Maintenance

1. Lubricate gear teeth and roller chain.
2. Clean and oil ratchet, pawl and other moving parts periodically to maintain free action and reduce wear. Clean and lubricate more often in environment where dust, dirt or other foreign particulates will effect the performance of moving parts.
3. Periodically inspect all moving parts, framework and contact areas for signs of wear, fatigue or loosening. Tighten, adjust or replace parts as necessary to prevent failure and maintain proper function.

Operator's Manual for Morse Model 185A Kontrol-Karrier
Serial number 0103 to ____ (MMYY)

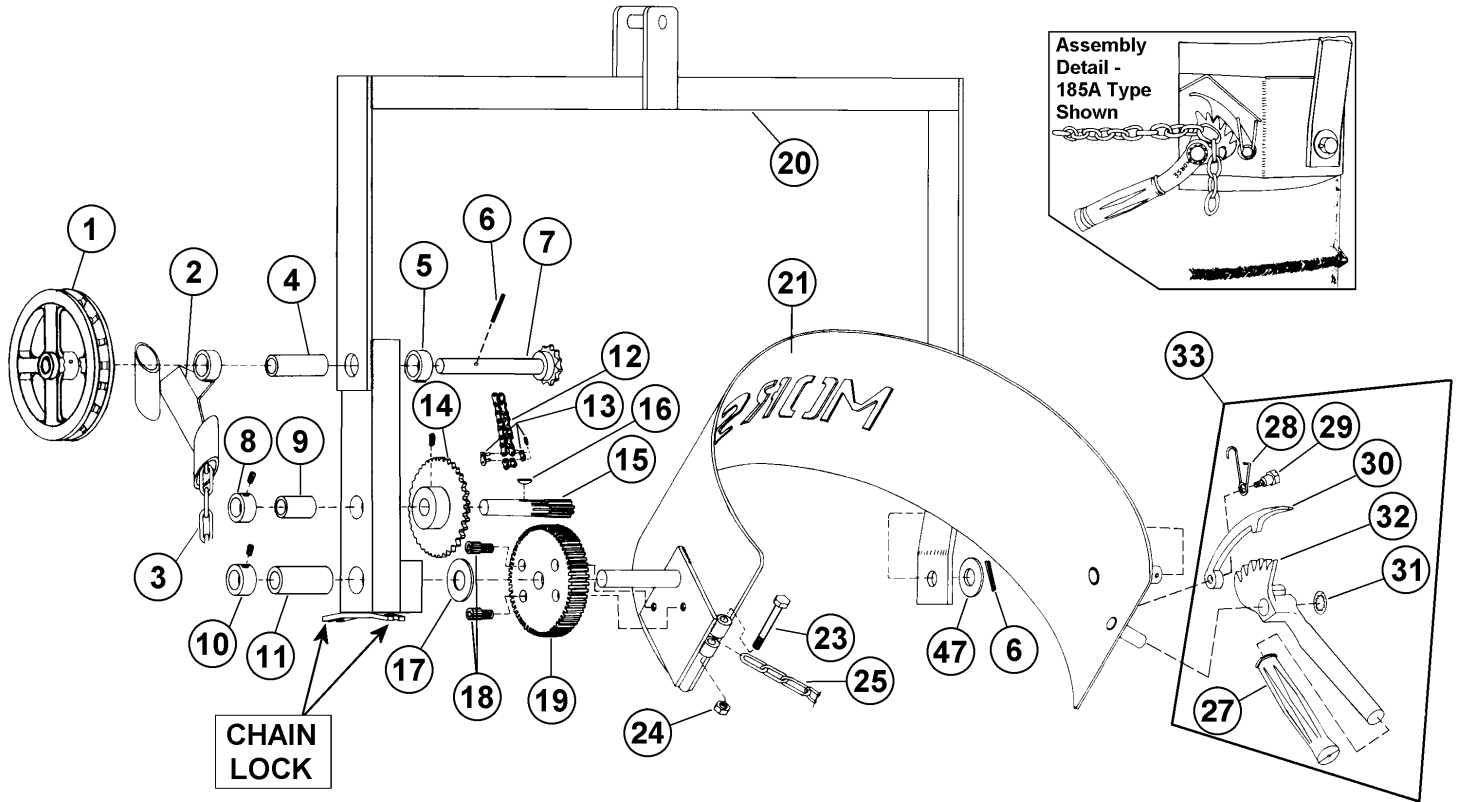

ITEM #	QTY.	PART #	DESCRIPTION
1*	1	1303-P	POCKET CHAIN WHEEL, 3/4 BORE
2	1	1304-P	GUIDE, POCKET CHAIN WHEEL
3*	1	3-185-P	CHAIN, PULL, POCKET 12' LENGTH
4*	1	19-P	BEARING, 3/4" ID X 2-1/2"
5	1	1411-P	SPACER, SHAFT W/ 12T SPROCKET
6	2	64-P	ROLL PIN, 3/16 X 1-1/4
7*	1	1302-P	SHAFT W/ 12T SPROCKET, POCKET
8	1	15-P	COLLAR, 3/4" ID
9*	1	7-P	BEARING, 3/4" ID X 1-1/2"
10	1	16-P	COLLAR, 1" ID
11*	1	18-P	BEARING, 1" ID X 2-1/2"
12*	1	12-P	CHAIN, ROLLER, #35 W/ M LINK
13	1	795-P	LINK, MASTER, #35 CHAIN
14*	1	13-P	SPROCKET #35 36T, 3/4" BORE
15*	1	14-P	GEAR, PINION, 7 TOOTH
16*	1	735-P	KEY, WOODRUFF, SIZE 9, ASA606
17	1	29-P	SPACER, SPUR GEAR .15"

ITEM #	QTY.	PART #	DESCRIPTION
18	2	22-P	SHCS, 3/8-24 X 5/8
19*	1	23-P	GEAR, SPUR, 72T, 1" HOLE
20	1	47-P	OVERHEAD LIFT YOKE 185A W/BRG
21 **	1	112A-P	SADDLE ASM, 185A
23*	1	4079-P	HHCS, M8 X 60 MM CL8.8, 8MM
24*	1	4081-P	NUT, M8 ESNA, 8MM
25*	1	180-P	CHAIN, CINCH, 3/16 ALLOY 33 LK
27	1	136-P	HANDLE GRIP, 7/8" X 4-3/4"
28	1	169-P	SPRING, PAWL
29	1	170-P	SCREW, 3/8 DIA X 5/8 SHOULDER
30	1	168-P	PAWL, WITH DRILLED HOLE
31	1	710-P	RETAINER, RATCHET PUSH NUT 3/4
32	1	165-P	RATCHET, MALLEABLE, SADDLE
33*	1	165KIT-P	KIT, RATCHET CHAIN TIGHTENER
47	1	55-P	WASHER, 3/4 SAE FL 1-1/2 OD

* Recommended spare parts.

** Item 21 "SADDLE ASM" (drum holder assembly) includes appropriate attached moving parts (items 23, 24, 25, and 33).