

CONTENTS

	Page
Receiving Procedures.	1
Warranty.	1
Safety Information.	1 - 2
Machine Description.	3
Accessories.	3
Operating Instructions.	4
Maintenance.	4
Parts List and Diagram.	5 - 7

Operator’s Manual
for Morse Kontrol-Karrier
with 3-Piece Drum Holder

Model 185G
Serial number 0616 to ____ (MMYY)

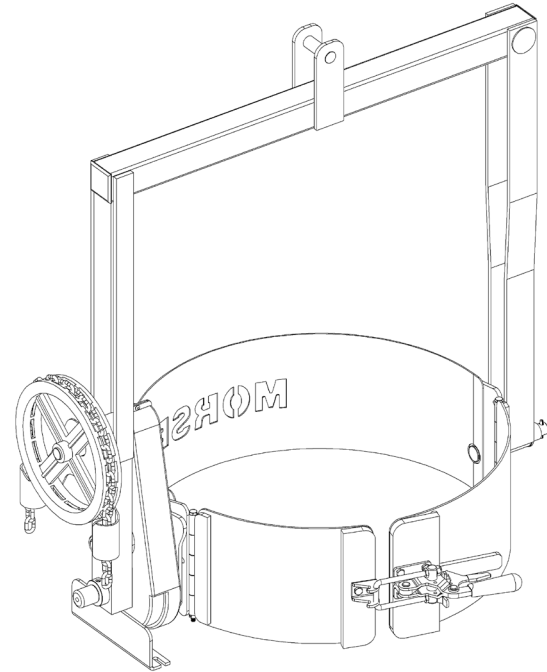

Receiving Procedures

Every Morse drum handler is inspected prior to shipping. However, damage may be incurred during transit.

- Check for visible damage. If you choose to accept damaged freight, always sign noting the damage on the **Bill of Lading**.
- Document the damage and have the truck driver sign. We recommend keeping a digital camera at your receiving dock for this purpose.
- Open packages expeditiously to check the condition of the goods. There is only a 24 hour window to notify the carrier of any concealed damage.
- Immediately **report all damage to the shipping company!** Then you may contact Morse for assistance with your freight claim.
- Morse Manufacturing will not be held responsible for any damaged freight that is not signed for as damaged.

Limited 2 Year Warranty

Morse drum handling equipment is guaranteed against defects in workmanship or materials for two years when used properly within its rated capacity. Warranty does not cover wear from normal use or damage from accident or abuse. Motors and other purchased parts carry the warranties of their manufacturers.

For warranty claims, contact your Morse Dealer to obtain a return authorization number, and for return freight advice. Return freight must be prepaid.

In all instances, liability is limited to the purchase price paid or to repairing or replacing the product. Customer assumes liability for any modifications, unauthorized repairs or parts substitution.

Safety Information

While Morse Manufacturing Co. drum handling equipment is engineered for safety and efficiency, a high degree of responsibility must be placed upon the machine operator to follow safe practices, based primarily on common sense, upon which true safety depends.



Failure to follow the safety precautions in this manual can result in personal injury or property damage. Observe the same precautions as with similar machinery where carelessness in operating or maintenance is hazardous to personnel. Carefully read the safety precautions below and throughout this manual.













Review the Material Safety Data Sheet(s) for the material(s) in the drum(s) and take all necessary precautions. Safety shoes, work gloves, hard hat and other personal protective devices are recommended.

Prior to initial use, inspect all moving parts and test rotation of chain wheel and drum holder assembly. Inspect drum holder assembly for proper operation. Perform necessary load test, inspections, operator training, etc.

Operator's Manual for Morse Kontrol-Karrier with 3-Piece Drum Holder
Model 185G Serial number 0616 to ____ (MMYY)

Safety Information (continued)

	DANGER - Indicates a situation which, if not avoided, will result in serious injury or death. This signal word is limited to the most extreme situations.
	WARNING - Indicates a situation which, if not avoided, could result in serious injury or death.
	CAUTION - Indicates a situation which, if not avoided, can result in damage to the machine.

-  **WARNING** - Kontrol-Karriers are designed to handle one drum of the types listed at the top of page 3. Machine Description. DO NOT attempt to handle any other type of drum or object.
-  **WARNING** - DO NOT exceed the weight capacity of 800 Lb. (363 kg).
-  **WARNING** - DO NOT operate damaged or malfunctioning unit, or a unit with missing parts.
-  **WARNING** - DO NOT lift people or suspend loads over people. Stay clear of suspended loads.
-  **WARNING** - DO NOT lift loads higher than necessary.
-  **WARNING** - DO NOT leave suspended loads unattended.
-  **WARNING** - DO NOT remove or obscure warning labels.
-  **WARNING** - DO NOT operate without first having read and understood operating manual.
-  **WARNING** - DO NOT make alterations or modify the unit. Under no circumstances should any modifications be made to the Morse machinery without factory authorization. Any modifications may void the warranty. This machine was designed to perform a specific job and alterations may result in injury to operator or machine.
-  **WARNING** - Wear safety shoes with non-slip soles and hard toe protection.
-  **CAUTION:** DO NOT allow drum to impact on floor, ground, etc.
-  **WARNING:** This product can expose you to chemicals including cobalt, titanium dioxide, and 2-methylimidazole, which are known to the State of California to cause cancer, and bisphenol-A, which is known to the State of California to cause birth defects or other reproductive harm. For more information go to www.P65Warnings.ca.gov

Operator's Manual for Morse Kontrol-Karrier with 3-Piece Drum Holder
Model 185G Serial number 0616 to ____ (MMYY)

Machine Description

Model 185G Kontrol-Karrier is designed to lift, transport, and dispense a ribbed 55-gallon (210 liter) steel drum 22.5" (57 cm) in diameter.

Maximum full-drum capacity is 800 Lb. (363 kg). Capacity is derated to 500 Lb. (227 kg) for a half-full drum. Half-full rating is based on the tilt mechanism's capacity for handling an unbalanced, bottom-heavy drum

MORSE
Mfg. Co., Inc.
E. Syracuse, NY

800 Lb.
(363 kg)

Lb. Max.
Capacity

The Specialist In Drum Handling Equipment

Made In U.S.A.

ACCESSORIES

to Install on EXISTING Manual Tilt Drum Handler

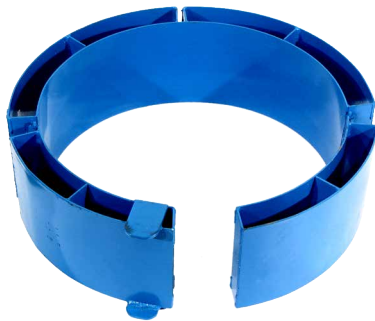

Model # 55/30-19GR Diameter Adapter for 30-gallon (114 liter) drum. Insert Diameter Adapter into drum holder to handle a 19" (48.3 cm) diameter steel drum.

NOTE: For 30-gallon (114 Liter) **PLASTIC** drum, insert Diameter Adapter; **AND** install Bracket or Top Rim Clamp to prevent drum slipping.

IMPORTANT: To prevent 30 or 55 gallon (114 or 210L) size plastic drum from slipping, you **MUST** install either Top Rim Clamp Kit or Bracket Assembly Kit.

- 1. Bracket Assembly Kit # 4556-P** is required to handle a RIMLESS plastic drum (figure 2.1), and is also recommended for a fiber drum. The Bracket adjusts for a 31" to 39" (79 to 99 cm) tall drum. You can also handle a rimmed drum with the Bracket installed.
- 2. Top Rim Clamp Kit # 4560B-P** to handle a RIMMED plastic drum (figure 2.2). Install the Top Rim Clamp Kit to handle a RIMMED plastic, steel or fiber drum with suitable top rim.

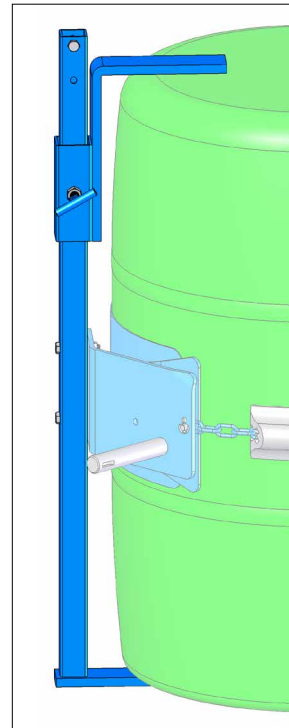

Figure 2.1

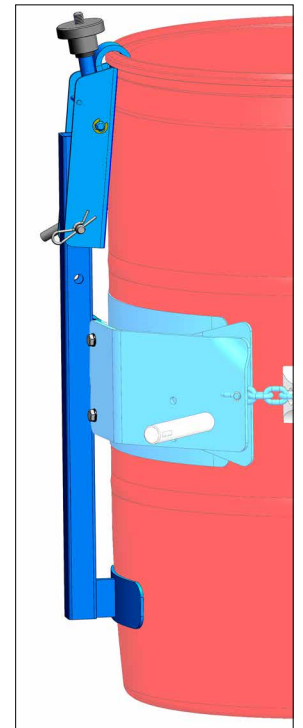
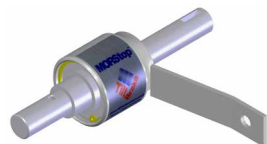
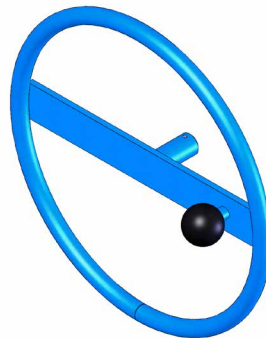

Figure 2.2

Kit # 3900-P MORStop™ Tilt-Brake
Automatically holds drum tilt angle until you move it.



Kit # 2690-P Hand Wheel
16" (40.6 cm) diameter Hand Wheel with speed knob. Replaces standard pull chain to turn drum.



Kit # 1460-P Hand Crank
9" (22.9 cm) Hand Crank. Replaces standard pull chain to turn drum.



Kit # 4556-P Bracket Assembly
to handle RIMLESS or RIMMED plastic drum



Kit # 4560B-P Top Rim Clamp
to handle RIMMED plastic drum



Kit # 6315-P Fork Pockets
Add fork pockets to below-hook drum handler

Operator's Manual for Morse Kontrol-Karrier with 3-Piece Drum Holder
Model 185G Serial number 0616 to ____ (MMYY)

Important

1. Please read all instructions thoroughly before attempting to operate your new Morse drum handler.
2. When loading, unloading, operating, or maintaining your MORSE drum handler, always use care and good judgment. Maintain secure footing and a firm hold. Keep hands and loose clothing away from all moving parts. Never allow anyone to be below any part of a raised drum handler or drum.
3. Read operating instructions and review pictures in sales brochure before operation.
4. 185 Series are a "Group 1 structural and mechanical" below-the-hook lifting devices which are covered by the American National Standard ASME B30.20. The user should comply with all aspects of this standard.

Operating Instructions

1. Start with Kontrol-Karrier on floor. Lower hoist and engage hoist hook to lift Kontrol-Karrier.
2. Raise hoist to lift Kontrol-Karrier clear of floor and transport it to drum.
3. Suspend Kontrol-Karrier at a height which aligns drum holder (saddle) with center of drum.
4. Open toggle clamp by activating release lever and swing both hinged bands to open position. Push Kontrol-Karrier against drum so that saddle will encircle drum.
5. Secure drum: Close two hinged bands around drum, latch toggle clamp (see detail A).
6. Raise hoist and position drum at pouring station.
7. Pour drum by pulling on pull chain loop and rotating drum to suitable pouring angle. For best control of drum pouring angle, pay out one side of chain loop while pulling in the other side, thus being able to hold back the drum rotation. Chain lock on bottom of power arm can be used to prevent drum rotation. To do so, crisscross chain and insert in each slot of chain lock. If drum handler is equipped with MORStop Tilt-Brake, there is no need to hold tension on both sides of chain loop. Braking is immediate and self actuating, without additional steps by the operator. To add MORStop Tilt-Brake to your drum handler, order Kit # 3900-P for a field installation kit.
8. After pouring is completed, rotate drum back to vertical position and lower hoist to return drum to floor.
9. To remove drum: Activate release lever, open toggle clamp and swing both hinged bands to open position.

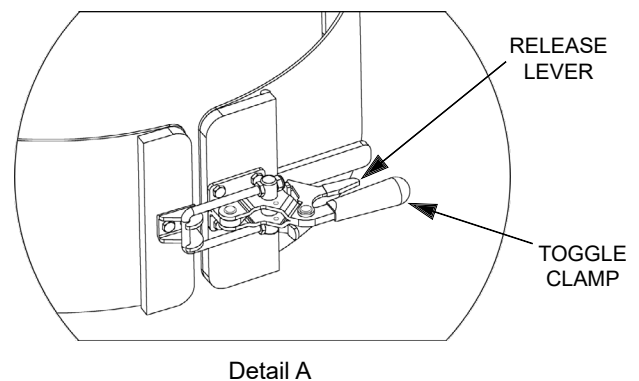
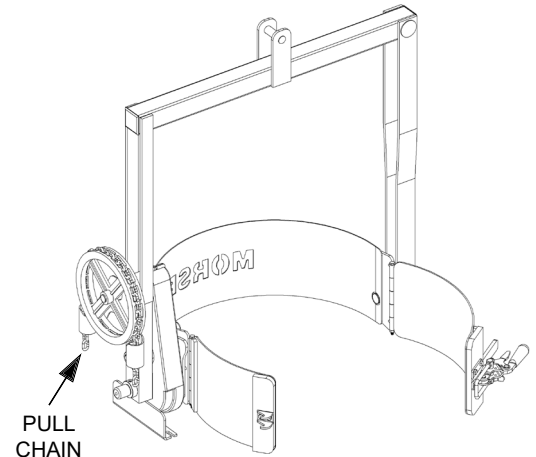

Detail A

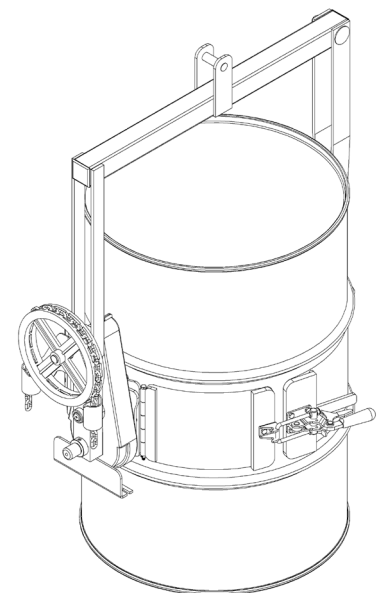

Maintenance

Periodic inspection for the general condition of structural and mechanical components is imperative for safe and efficient operation.

1. Lubricate gear teeth and roller chain.
2. Clean and oil saddle hinges and other moving parts periodically. Clean and lubricate more often in environments where dust, dirt or other foreign particles will effect the performance of moving parts.
3. Periodically inspect all moving parts, framework, drum holder and contact areas for signs of wear, fatigue, or loosening. Tighten, adjust, or replace parts as necessary to prevent failure and maintain proper function.
4. Worn or damaged parts must be properly replaced with correct, genuine Morse parts.

Operator's Manual for Morse Kontrol-Karrier with 3-Piece Drum Holder Model 185G Serial number 0616 to ____ (MMYY)

IMPORTANT NOTE

4-Digit serial numbers are simply the month & year of manufacture

Example: 0802 is August 2002

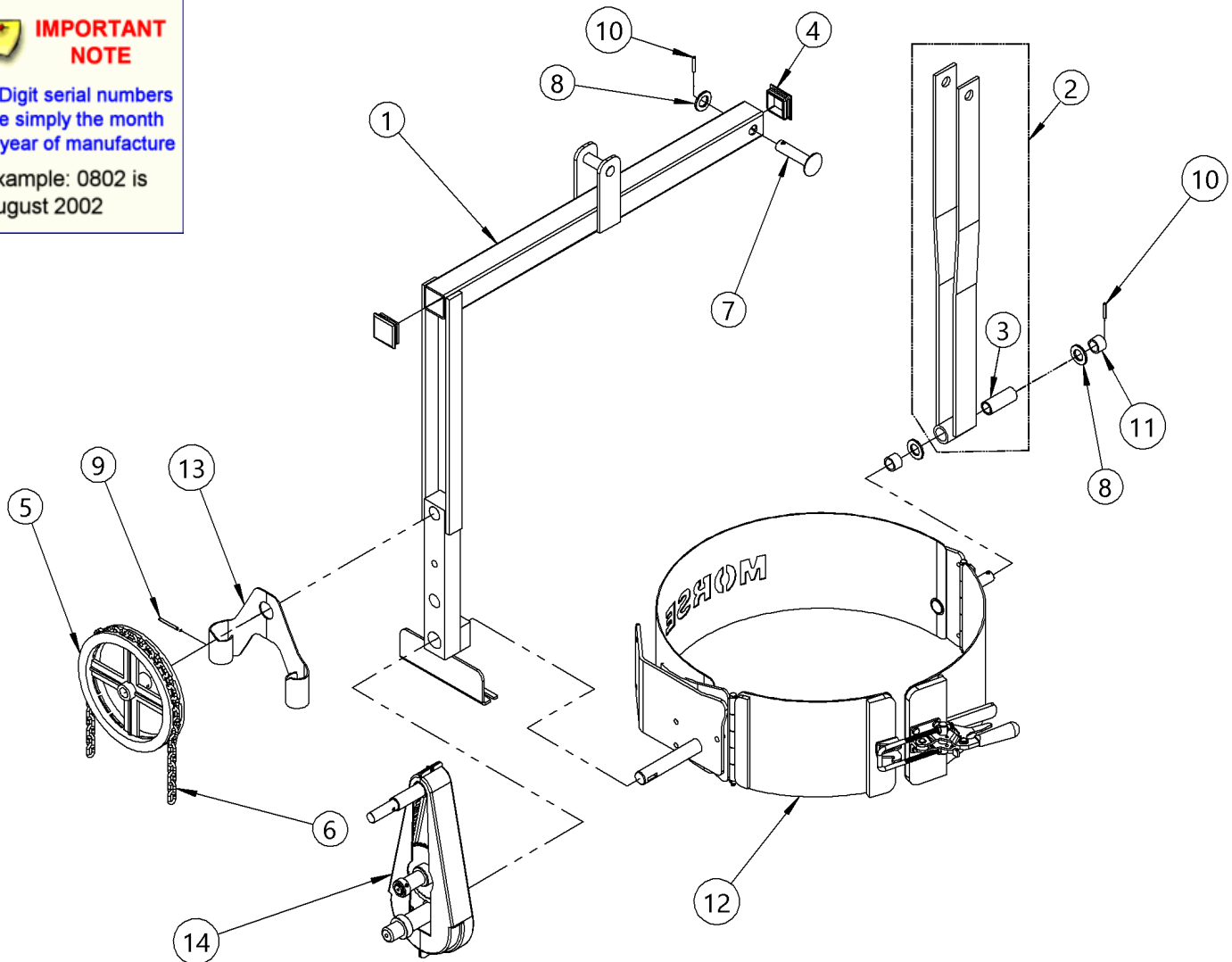

ITEM NO.	PART NUMBER	DESCRIPTION	QTY.
1	4494-P	OVERHEAD YOKE WELD, 185A MOR	1
2	4497B-P	IDLER ARM W/BRG, 185A & HD MOR	1
3	19-P	BEARING, 3/4" ID X 2-1/2"	1
4	4602-P	CAP, 2 X 2, PLASTIC	2
5	1303-P	POCKET CHAIN WHEEL, 3/4 BORE	1
6	3-185-P	PULL CHAIN, POCKET, 12' LENGTH	1
7	1436-P	CLEVIS PIN, LARGE TUBE, 92	1
8	55-P	WASHER, 3/4 SAE FL 1-1/2 OD	3
9	5269-P	ROLL PIN, 3/16 X 1-3/4	1
10	64-P	ROLL PIN, 3/16 X 1-1/4	2
11	1411-P	SPACER, SHAFT W/ 12T SPROCKET	2
12	5000G-P	SADDLE ASM, MORCINCH, 3PC	1
13	5245-P	GUIDE, POCKET CHAIN WHEEL	1
14	→	POWER TRAIN, SEE NEXT PAGE	1

Operator's Manual for Morse Kontrol-Karrier with 3-Piece Drum Holder
 Model 185G Serial number 0616 to ____ (MMYY)

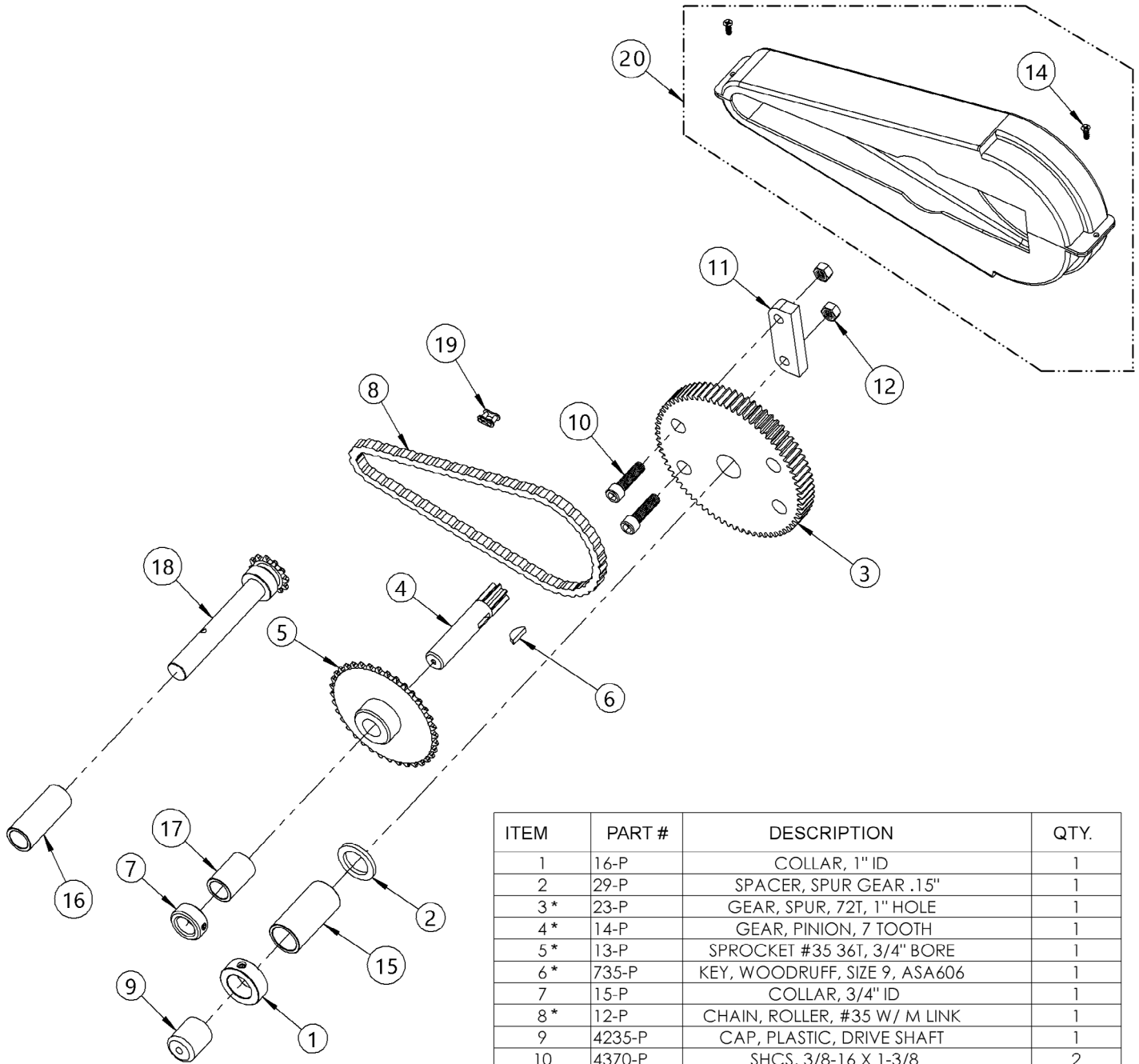

ITEM	PART #	DESCRIPTION	QTY.
1	16-P	COLLAR, 1" ID	1
2	29-P	SPACER, SPUR GEAR .15"	1
3*	23-P	GEAR, SPUR, 72T, 1" HOLE	1
4*	14-P	GEAR, PINION, 7 TOOTH	1
5*	13-P	SPROCKET #35 36T, 3/4" BORE	1
6*	735-P	KEY, WOODRUFF, SIZE 9, ASA606	1
7	15-P	COLLAR, 3/4" ID	1
8*	12-P	CHAIN, ROLLER, #35 W/ M LINK	1
9	4235-P	CAP, PLASTIC, DRIVE SHAFT	1
10	4370-P	SHCS, 3/8-16 X 1-3/8	2
11	4473-P	SPACER, SPUR GEAR, U	1
12	1169-P	NUT, 3/8-16 REV HEX LOCK	2
14	4481-P	SCREW, 8-32 X 1/2", FH	2
15*	18-P	BEARING, 1" ID X 2-1/2"	1
16*	19-P	BEARING, 3/4" ID X 2-1/2"	1
17*	7-P	BEARING, 3/4" ID X 1-1/2"	1
18*	5135-P	SHAFT, 12T SPROCKET & SPACER	1
19	795-P	LINK, MASTER, #35 CHAIN	1
20	4285-P	COVER SET, BLK POLY 30:1 REG	1

Operator's Manual for Morse Kontrol-Karrier with 3-Piece Drum Holder Model 185G Serial number 0616 to ____ (MMYY)

IMPORTANT NOTE

4-Digit serial numbers are simply the month & year of manufacture

Example: 0802 is August 2002

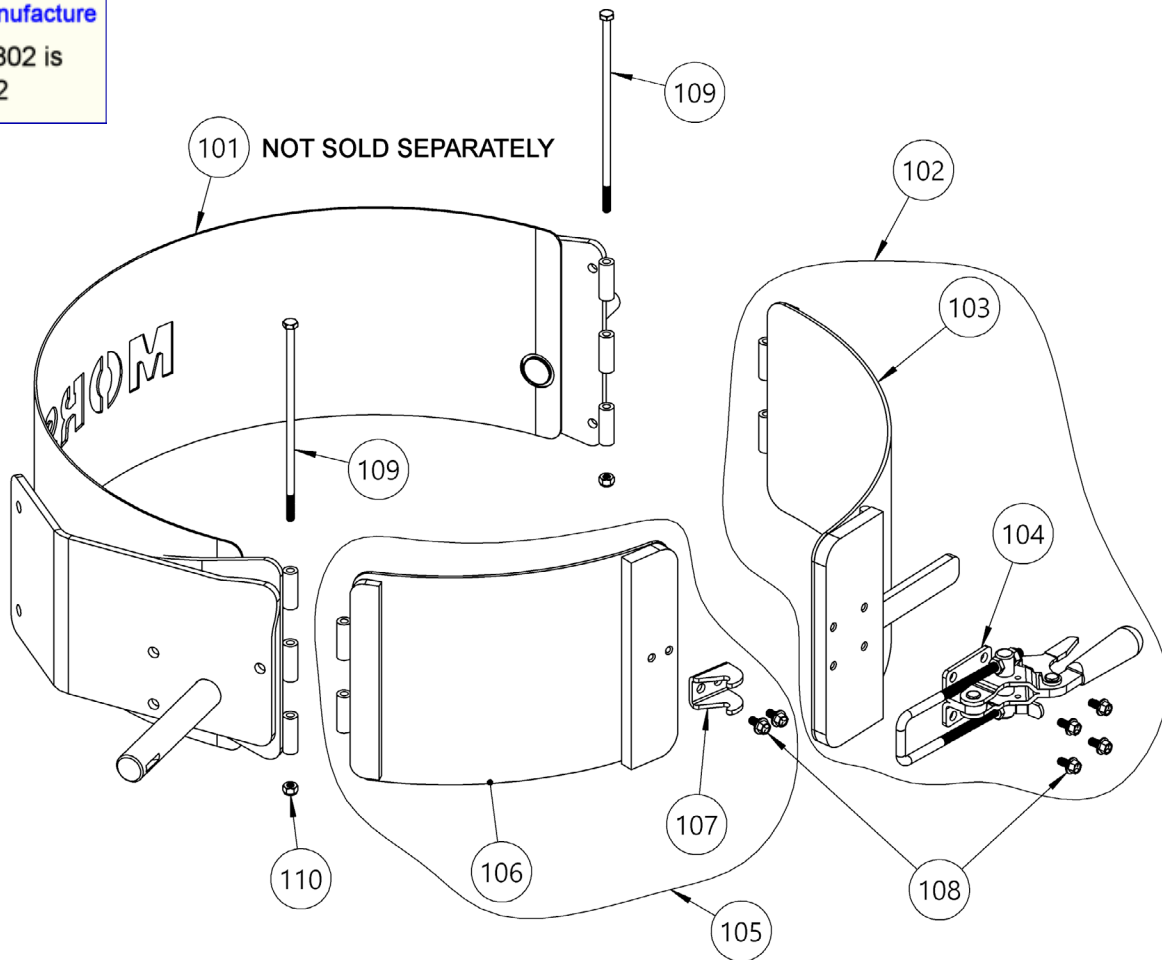

ITEM NO.	PART NUMBER	DESCRIPTION	QTY.
101	4210G-P	SADDLE WELD, MOR, 3PC	1
102	5933-P	HINGE CPT, CLAMP, 3PC, MOR	1
103	5933W-P	WELD, IDLER HINGE BAND, 3PC	1
104	6018-P	TOGGLE CLAMP, W/ 6" U, 5000G-P	1
105	5934-P	HINGE CPT, CATCH, 3PC, MOR	1
106	5934W-P	WELD, DRIVE HINGE BAND, 3PC	1
107	5932-P	CATCH, 341-R TOGGLE, CAMLOCK	1
108	4064-P	HHCS, 1/4-20 X 1/2 SER FLG	6
109	1296-P	HHCS, 1/4-20 X 7-1/2 GR5	2
110	1518-P	NUT, 1/4-20 NYLON LOCK	2