

**Contents**

	Page
Receiving Procedures. . . . .	1
Warranty. . . . .	1
Safety Information. . . . .	1 - 2
Machine Description. . . . .	3
Operating Instructions. . . . .	4
Maintenance. . . . .	4
Parts List and Diagram. . . . .	5 - 6
Recommended Spare Parts. . . . .	7

**Operator's Manual**  
**for Morse Heavy-Duty Kontrol-Karrier**  
**with 3-Piece Drum Holder**

**Model 185G-HD**  
**Serial number 0309 to \_\_\_\_ (MMYY)**



**Receiving Procedures**

Every Morse drum handler is inspected prior to shipping. However, damage may be incurred during transit.

- Check for visible damage. If you choose to accept damaged freight, always sign noting the damage on the **Bill of Lading**.
- Document the damage and have the truck driver sign. We recommend keeping a digital camera at your receiving dock for this purpose.
- Open packages expeditiously to check the condition of the goods. There is only a 24 hour window to notify the carrier of any concealed damage.
- Immediately **report all damage to the shipping company!** Then you may contact Morse for assistance with your freight claim.
- Morse Manufacturing will not be held responsible for any damaged freight that is not signed for as damaged.

**Limited 2 Year Warranty**

Morse drum handling equipment is guaranteed against defects in workmanship or materials for two years when used properly within its rated capacity. Warranty does not cover wear from normal use or damage from accident or abuse. Motors and other purchased parts carry the warranties of their manufacturers.

For warranty claims, contact your Morse Dealer to obtain a return authorization number, and for return freight advice. Return freight must be prepaid.

In all instances, liability is limited to the purchase price paid or to repairing or replacing the product. Customer assumes liability for any modifications, unauthorized repairs or parts substitution.

**Safety Information**

While Morse Manufacturing Co. drum handling equipment is engineered for safety and efficiency, a high degree of responsibility must be placed upon the machine operator to follow safe practices, based primarily on common sense, upon which true safety depends.

Failure to follow the safety precautions in this manual can result in personal injury or property damage. Observe the same precautions as with similar machinery where carelessness in operating or maintenance is hazardous to personnel. Carefully read the safety precautions below and throughout this manual.

Review the Material Safety Data Sheet(s) for the material(s) in the drum(s) and take all necessary precautions. Safety shoes, work gloves, hard hat and other personal protective devices are recommended.

Prior to initial use, inspect all moving parts and test rotation of chain wheel and drum holder assembly. Inspect drum holder assembly for proper operation. Perform necessary load test, inspections, operator training, etc.

### Operator's Manual for Morse Model 185G-HD Heavy-Duty Kontrol-Karrier Serial number 0309 to \_\_\_\_ (MMYY)

#### Safety Information (continued)



**DANGER** - Indicates a situation which, if not avoided, will result in serious injury or death. This signal word is limited to the most extreme situations.



**WARNING** - Indicates a situation which, if not avoided, could result in serious injury or death.



**CAUTION** - Indicates a situation which, if not avoided, can result in damage to the machine.



**WARNING** - Kontrol-Karriers are designed to handle one drum of the types listed at the top of page 3. Machine Description. DO NOT attempt to handle any other type of drum or object.



**WARNING** - DO NOT exceed the weight capacity of 1500 Lb.



**WARNING** - DO NOT operate damaged or malfunctioning unit, or a unit with missing parts.



**WARNING** - DO NOT lift people or suspend loads over people. Stay clear of suspended loads.



**WARNING** - DO NOT lift loads higher than necessary.



**WARNING** - DO NOT leave suspended loads unattended.



**WARNING** - DO NOT remove or obscure warning labels.



**WARNING** - DO NOT operate without first having read and understood operating manual.



**WARNING** - DO NOT make alterations or modify the unit. Under no circumstances should any modifications be made to the Morse machinery without factory authorization. Any modifications may void the warranty. This machine was designed to perform a specific job and alterations may result in injury to operator or machine.



**WARNING** - Wear safety shoes with non-slip soles and hard toe protection.



**CAUTION:** DO NOT allow drum to impact on floor, ground, etc.

**Operator's Manual for Morse Model 185G-HD Heavy-Duty Kontrol-Karrier**  
Serial number 0309 to \_\_\_\_ (MMYY)

**Machine Description**

**Model 185G-HD Heavy-Duty** Kontrol-Karrier is designed to lift, transport and dispense a ribbed 55-gallon steel drum 22.5" in diameter. The maximum full-drum capacity is 1500 Lb. The capacity is derated to 800 Lb. for a half-full drum. The half-full drum rating is based on the tilt mechanism's capacity for handling an unbalanced, bottom heavy load.



**Option**

- A 19" diameter drum can be handled with model 55/30-19GR Diameter Adaptor installed.

**Important**

1. Please read all instructions thoroughly before attempting to operate your new Morse drum handler.
2. When loading, unloading, operating, or maintaining your MORSE drum handler, always use care and good judgment. Maintain secure footing and a firm hold. Keep hands and loose clothing away from all moving parts. Never allow anyone to be below any part of a raised drum handler or drum. Read operating instructions and review the pictures in the sales brochure before operation.
3. The 185 Heavy-Duty Series are a "Group 1 structural and mechanical" below-the-hook lifting device which are covered by the American National Standard ASME B30.20. The user should comply with all aspects of this standard.

**Operator's Manual for Morse Model 185G-HD Heavy-Duty Kontrol-Karrier**  
**Serial number 0309 to \_\_\_\_ (MMYY)**

**Operating Instructions**

1. Start with Kontrol-Karrier on the floor. Lower hoist and engage hoist hook in off-center lift point to lift Kontrol-Karrier without drum.
2. Raise hoist to lift Kontrol-Karrier clear of floor and transport it to the drum.
3. Suspend Kontrol-Karrier at a height which aligns drum saddle with center of drum.
4. Pull the linch pin (item 109), open the toggle clamp and swing both hinged bands to the open position. Push Kontrol-Karrier against drum so that saddle will encircle drum.
5. Secure the drum: Close the two hinged bands around the drum, latch the toggle clamp and insert the linch pin (see detail A).
6. Move hoist hook to center lift point. Raise hoist and position drum at pouring station.
7. Pour the drum by pulling on the pull chain (item 11) and rotating the drum to a suitable pouring angle. For best control of drum pouring angle, pay out one side of the chain loop while pulling in the other side, thus being able to hold back the drum rotation. The chain lock on the bottom of the power arm can be used to prevent drum rotation. To do so, criss cross the chain and insert in each slot of the chain lock. If the drum handler is equipped with the MORStop Tilt-Brake, there is no need to hold tension on both sides of the chain loop. Braking is immediate and self actuating, without additional steps by the operator. To add the MORStop Tilt-Brake to your drum handler, order part # 3900-P for a field installation kit.
8. After pouring is completed, rotate drum back to vertical position and lower hoist to return drum to floor.
9. To remove drum: Pull the linch pin, open the toggle clamp and swing both hinged bands to the open position.

**Maintenance**

1. Periodic inspection for the general condition of structural and mechanical components is imperative for safe and efficient operation.
2. Lubricate gear teeth and roller chain.
3. Clean and oil saddle hinges and other moving parts periodically to maintain free action and reduce wear. Clean and lubricate more often in environment where dust, dirt or other foreign particles will effect the performance of moving parts.
4. Periodically inspect all moving parts, framework and contact areas for signs of wear, fatigue or loosening. Tighten, adjust or replace parts as necessary to prevent failure and maintain proper function.
5. Worn or damaged parts must be properly replaced with the correct, genuine Morse parts

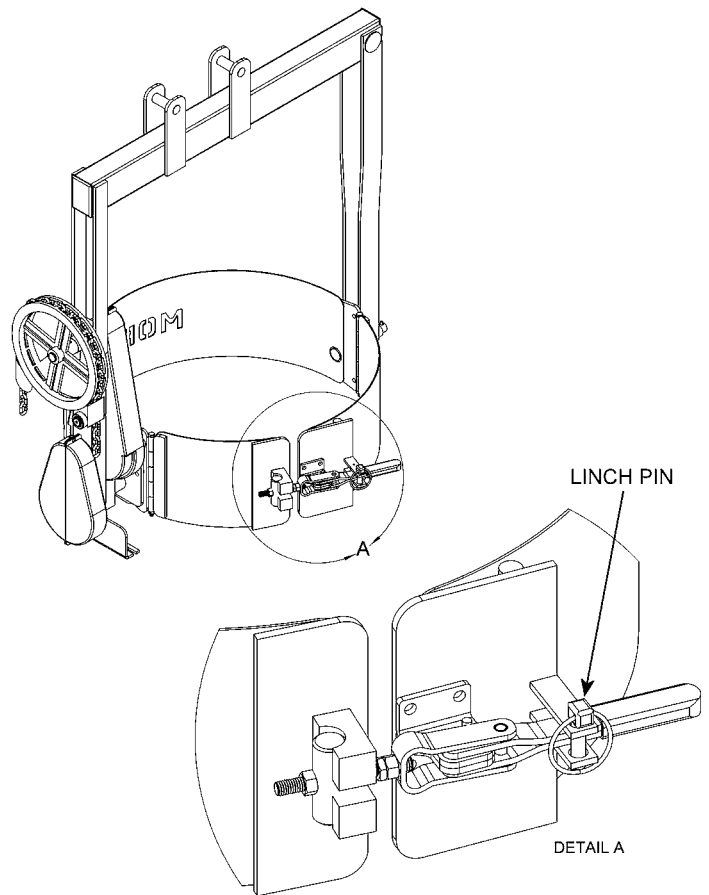

### Operator's Manual for Morse Model 185G-HD Heavy-Duty Kontrol-Karrier Serial number 0309 to \_\_\_\_ (MMYY)

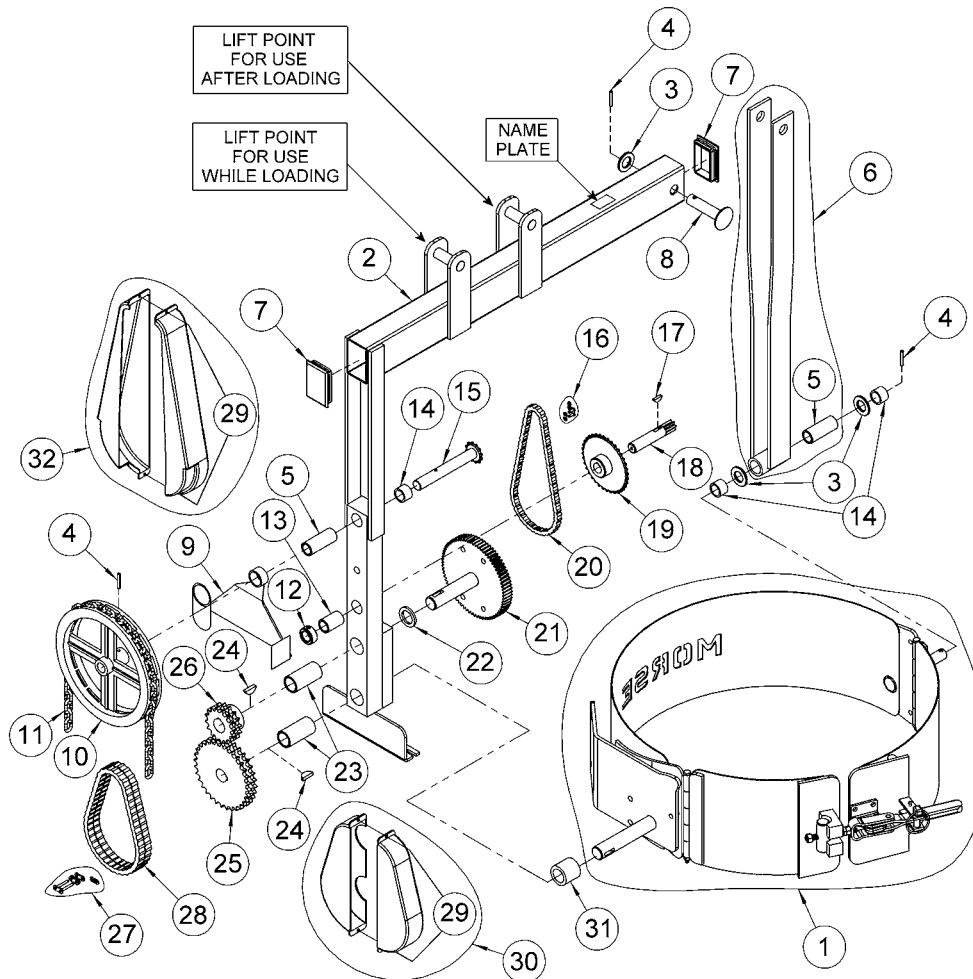

ITEM	QTY.	PART #	DESCRIPTION
1	1	5000G-P	SADDLE ASM, MORCINCH, MOR, 3PC
2	1	4503-P	OVERHEAD YOKE WELD 185A-HD MOR
3	3	55-P	WASHER, 3/4 SAE FL 1-1/2 OD
4*	3	64-P	ROLL PIN, 3/16 X 1-1/4
5*	2	19-P	BEARING, 3/4" ID X 2-1/2"
6	1	4497B-P	IDLER ARM W/BRG, 185A & HD MOR
7	2	4603-P	CAP, 2 X 3, PLASTIC
8	1	1436-P	CLEVIS PIN, LARGE TUBE, 92
9*	1	1304-P	GUIDE, POCKET CHAIN WHEEL
10*	1	1303-P	POCKET CHAIN WHEEL, 3/4 BORE
11*	1	3-185-P	CHAIN, PULL, POCKET 12' LENGTH
12	1	15-P	COLLAR, 3/4" ID
13*	1	7-P	BEARING, 3/4" ID X 1-1/2"
14*	3	1411-P	SPACER, SHAFT W/ 12T SPROCKET
15*	1	1302-P	SHAFT W/ 12T SPROCKET, POCKET
16	1	795-P	LINK, MASTER, #35 CHAIN

ITEM	QTY.	PART #	DESCRIPTION
17*	1	735-P	KEY, WOODRUFF, SIZE 9, ASA606
18*	1	14-P	GEAR, PINION, 7 TOOTH
19*	1	13-P	SPROCKET #35 36T, 3/4" BORE
20*	1	12-P	CHAIN, ROLLER, #35 W/ M LINK
21*	1	27-P	SPUR GEAR W/ 1" SHAFT, HD TYPE
22	1	29-P	SPACER, SPUR GEAR .15"
23*	2	18-P	BEARING, 1" ID X 2-1/2"
24*	2	736-P	KEY, WOODRUFF, SIZE 15, ASA808
25*	1	32-P	SPROCKET #40D 32T, 1" BORE
26*	1	30-P	SPROCKET #40D 16T, 1" BORE
27	1	796-P	LINK, MASTER, #40D CHAIN
28*	1	31-P	CHAIN, ROLLER, #40D W/ M. LINK
29	4	2182-P	WIRE / CABLE TIE, 4-33/64 (NOT SHOWN)
30	1	4284-P	COVER SET, 40D SPROCKETS
31	1	4372-P	SPACER, HD DRIVE SHAFT 1.4"
32	1	4286-P	COVER SET, 30:1 GEARS, HD

\* Recommended spare parts.

Operator's Manual for Morse Model 185G-HD Heavy-Duty Kontrol-Karrier  
Serial number 0309 to \_\_\_\_ (MMYY)

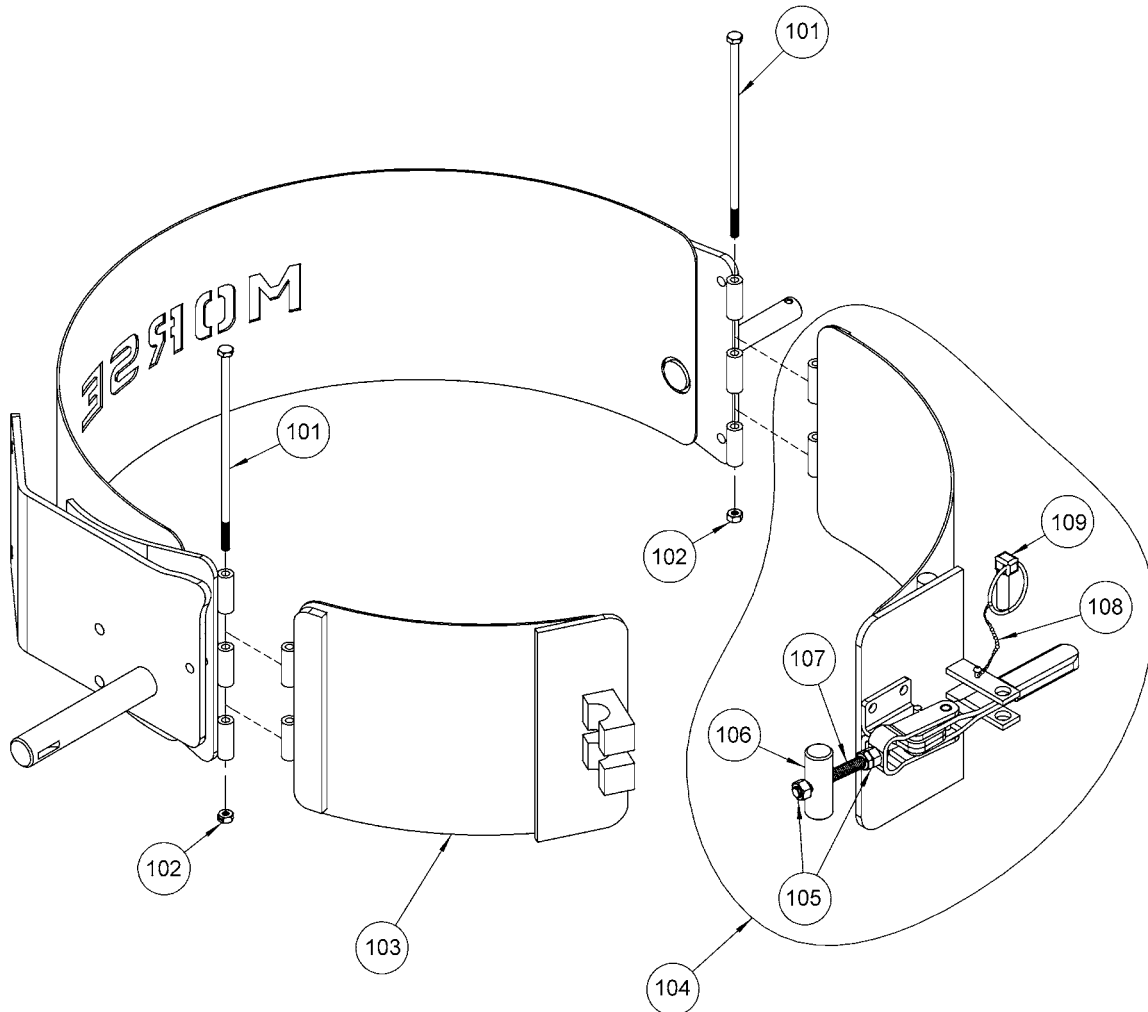

ITEM	QTY.	PART #	DESCRIPTION
101	2	1296-P	HHCS, 1/4-20 X 7-1/2 GR5
102	2	1297-P	NUT, 1/4-20 REV HEX LOCK
103	1	4491-P	HINGE CPT, DRIVE, 3PC, MOR
104	1	4490-P	HINGE CPT, IDLER, 3PC, MOR
105	2	2872-P	NUT, 3/8-24 FIN HEX, PCR-2000
106	1	2674-P	THREADED BARREL, CAMLOCK
107	1	2870-P	THREADED ROD, PCR-2000
108	1	2680-P	CHAIN, KEEPER, LINCH PIN, 6"
109	1	2871-P	LINCH PIN, 3PC SADDLE

**Operator's Manual for Morse Model 185G-HD Heavy-Duty Kontrol-Karrier**  
**Serial number 0309 to \_\_\_\_ (MMYY)**

**Recommended Spare Parts Kit Number: RP185-12.01**

**Kit Description: Kit, Spare Parts, 185G-HD**

Qty.	Part #	Description
3	64-P	ROLL PIN, 3/16 X 1-1/4
2	19-P	BEARING, 3/4" ID X 2-1/2"
1	1304-P	GUIDE, POCKET CHAIN WHEEL
1	1303-P	POCKET CHAIN WHEEL, 3/4 BORE
1	3-185-P	CHAIN, PULL, POCKET 12' LENGTH
1	7-P	BEARING, 3/4" ID X 1-1/2"
3	1411-P	SPACER, SHAFT W/ 12T SPROCKET
1	1302-P	SHAFT W/ 12T SPROCKET, POCKET
1	735-P	KEY, WOODRUFF, SIZE 9, ASA606
1	14-P	GEAR, PINION, 7 TOOTH
1	13-P	SPROCKET #35 36T, 3/4" BORE
1	12-P	CHAIN, ROLLER, #35 W/ M LINK
1	27-P	SPUR GEAR W/ 1" SHAFT, HD TYPE
2	18-P	BEARING, 1" ID X 2-1/2"
2	736-P	KEY, WOODRUFF, SIZE 15, ASA808
1	32-P	SPROCKET #40D 32T, 1" BORE
1	30-P	SPROCKET #40D 16T, 1" BORE
1	31-P	CHAIN, ROLLER, #40D W/ M. LINK