

Contents

	Page
Receiving Procedures.	1
Warranty.	1
Safety Information.	1 - 2
Machine Description.	2
Operating Instructions.	3
Maintenance.	3
Parts Lists and Diagram.	4 - 5

Operator's Manual

for Morse Spark Resistant Kontrol-Karrier with Air Power Tilt Model 195AM-A

Serial Number 224429 to 237662

Receiving Procedures

Every Morse drum handler is inspected prior to shipping. However, damage may be incurred during transit.

- Check for visible damage. If you choose to accept damaged freight, always sign noting the damage on the **BILL OF LADING**.
- Document the damage and have the truck driver sign. We recommend keeping a digital camera at your receiving dock for this purpose.
- Open packages expeditiously to check the condition of the goods. There is only a 24 hour window to notify the carrier of any concealed damage.
- **IMMEDIATELY REPORT ALL DAMAGE TO THE SHIPPING COMPANY!** Then you may contact Morse for assistance with your freight claim.
- Morse Manufacturing will not be held responsible for any damaged freight that is not signed for as damaged.

Delivery to non-business addresses without a loading dock result in additional freight charges. Residential delivery fees, inside delivery fees, re-delivery charges, and lift gate services will be added by the truck line, and are non-negotiable.

Limited 2 Year Warranty

Morse drum handling equipment is guaranteed against defects in workmanship or materials for **TWO YEARS** when used properly within its rated capacity. Warranty does not cover wear from normal use or damage from accident or abuse. Motors and other purchased parts carry the warranties of their manufacturers.

For warranty claims, contact your Morse Dealer to obtain a return authorization number, and for return freight advice. Return freight must be prepaid.

In all instances, liability is limited to the purchase price paid or to repairing or replacing the product. Customer assumes liability for any modifications, unauthorized repairs or parts substitution.

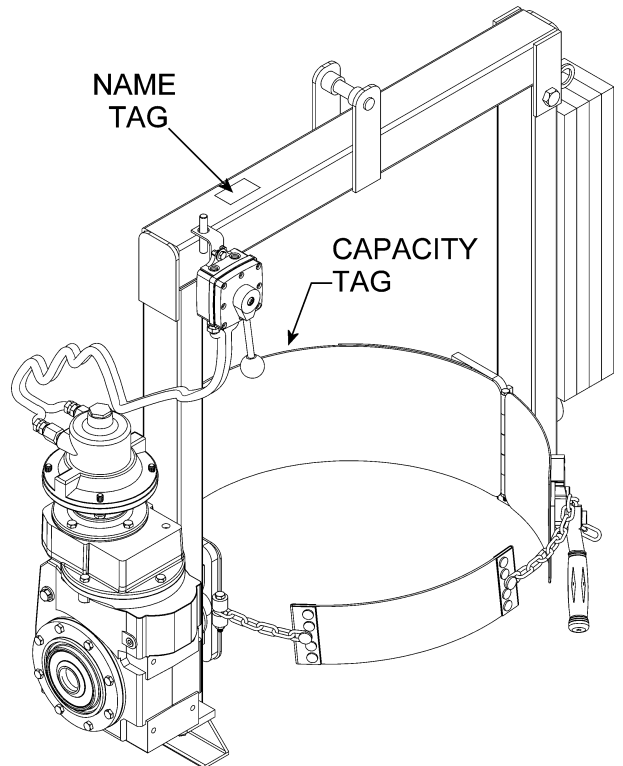

Safety Information

While Morse Manufacturing Co. drum handling equipment is engineered for safety and efficiency, a high degree of responsibility must be placed upon the machine operator to follow safe practices, based primarily on common sense, upon which true safety depends.

Failure to follow the safety precautions in this manual can result in personal injury or property damage. Observe the same precautions as with similar machinery where carelessness in operating or maintenance is hazardous to personnel. Carefully read the safety precautions throughout this manual.

Safety Information (continued)



DANGER - Indicates a situation which, if not avoided, *will* result in serious injury or death. This signal word is limited to the most extreme situations.



WARNING - Indicates a situation which, if not avoided, *could* result in serious injury or death.



CAUTION - Indicates a situation which, if not avoided, can result in damage to the machine.



WARNING

The Kontrol-Karrier is designed to handle one drum of the types listed under **Machine Description**. **DO NOT** attempt to handle any other type of drum or object. **DO NOT** exceed the weight capacity of 1,500 Lb. full drum and 800 Lb. half-full drum.



WARNING - Do Not Modify the Unit

Under no circumstances should any modifications be made to the Morse machinery without factory authorization. Any modifications may void the warranty. This machine was designed to perform a specific job and alterations may result in injury to operator or machine.



WARNING - No Loose Fitting Clothing

Wear close-fitting clothing and safety equipment appropriate to the job. Loose fitting clothing may become caught on the machinery and cause severe personal injury.



WARNING - Wear Safety Shoes

Wear safety shoes with non-slip soles and hard toe protection.



WARNING - Watch Out for Pinch Points

Stay clear of moving parts.



CAUTION - DO NOT allow drum to impact on floor, ground, or dumping station, etc.

Important

1. Review the Material Safety Data Sheet(s) for the material(s) in the drum(s) and take all necessary precautions. Safety shoes, work gloves, hard hat and other personal protective devices are recommended.
2. Please read all instructions *thoroughly* before attempting to operate your new MORSE drum handler.

Machine Description

1. The model 195AM-A has a maximum capacity rating of 1,500 Lb. full drum and 800 Lb. half-full drum and is designed to lift, move and pour *55-gallon steel drums*. **DO NOT** exceed these ratings. Exceeding these ratings or handling drums other than those mentioned above is unsafe and could result in equipment damage, excessive wear or awkward handling. Options and accessories are available for model 195AM-A to enable handling different sizes and types of drums (see Options and Accessories).
2. The model 195AM-A is a "Group 1 - Structural and Mechanical" Below-the-Hook Lifting Device which is covered by the American National Standard ANSI/ASME B30.20. The user should comply with all aspects of this standard.
3. When loading, unloading, operating, or maintaining your MORSE drum handler, always use care and good judgment. Maintain secure footing and a firm hold. Keep hands and loose clothing away from all moving parts. Never allow anyone to be below any part of a raised drum handler or drum. Read operating instructions and review the pictures in the sales brochure before operation.

Morse Spark Resistant Kontrol-Karrier with Air Power Tilt Model 195AM-A
Serial Number 224429 to 237662

Assembly Instructions

1. Install speed reducer oil vent plug and check oil level as shown in the speed reducer owners manual.
2. Air motor requires 40 PSI at 22 SCFM. Operating the air motor at higher pressures will reduce the life of the air motor and power transmission components.
3. Prior to initial use, inspect all moving parts and test rotation of saddle assembly. Inspect rubber strap and cinch chain for proper operation. Perform necessary load test, inspections, operator training, etc. as prescribed in the ANSI/ASME B30.20 standard.

Operating Instructions

1. With Kontrol-Karrier standing on the floor, lower hoist and engage hoist hook into the lifting eye.
2. Raise hoist to lift Kontrol-Karrier clear of floor and move it to the drum.
3. Position Kontrol-Karrier at a height which aligns the saddle band with the center of the drum.
4. With the rubber strap (item 25) hanging freely, push Kontrol-Karrier against the drum to surround the drum with the saddle band.
5. Drape the rubber strap across the front of the drum and insert one chain link into the slot on the ratchet (item 22). Turn the ratchet clockwise to tighten the cinch chain around the drum.
6. Raise hoist and position the drum at the pouring station.
7. Pour the drum by pulling lever clockwise on the control valve (item 3).
8. After pouring is completed, rotate the drum back to vertical position and lower hoist to return drum to floor.
9. To remove drum: Pull ratchet clockwise to relieve pressure on ratchet teeth. Lift pawl (item 18) to release teeth engagement and rotate ratchet counter-clockwise to loosen chain and allow its removal from notch.

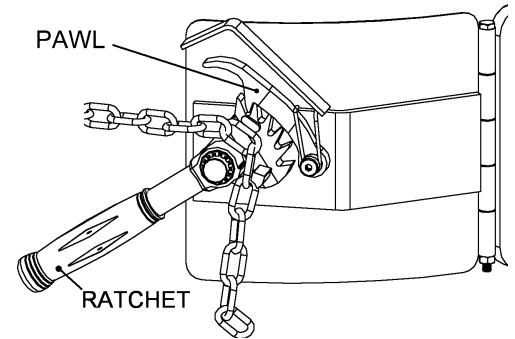

Maintenance

1. Inspect oil level in speed reducer.
2. Periodically inspect all moving parts, framework, rubber strap, and contact areas for signs of wear, fatigue, or loosening. Perform all inspections, load tests, and maintenance according to the ANSI/ASME B30.20 standard.
3. Ensure all labels are in place. Product labels should be inspected periodically and cleaned as necessary to maintain good legibility. Please contact Morse Mfg. Co. for replacement labels.



Options and Accessories to enable handling different sizes and types of drums with model 195AM-A.

A smaller diameter drum can be handled if the correct size Diameter Adaptor is installed. Adaptors simply lift in and out of the drum holder. See Diameter Adaptor literature.

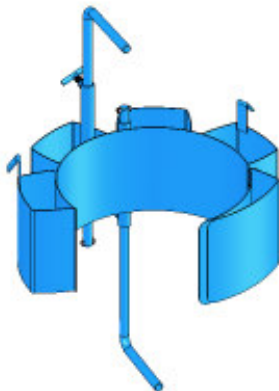

Model 55/30M-16
for 15.5" to 16" diameter drum.



Model 55/30M-19 for
18.5" to 19" diameter drum.

A 55-gallon plastic drum can be handled if the unit is equipped with the adjustable HDPS Bracket (Part # 1465M-P). This bracket fits into socket tube on the drum holder, and prevents a 55-gallon plastic drum from slipping lengthways.

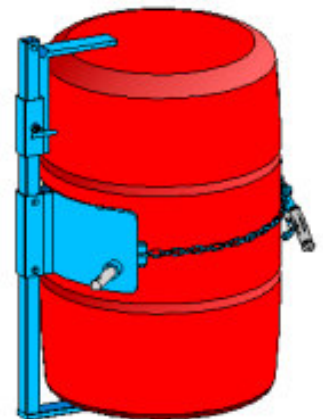

Parts List for Morse Spark Resistant Kontrol-Karrier with Air Power Tilt
Model 195AM-A
Serial Number 224429 to 237662

ITEM #	QTY.	PART #	DESCRIPTION
1	2	1518-P	NUT, LOCK, 1/4-20 NYLON
2	1	2888-P	MOUNT, CONTROL VALVE, 195A-A
3	1	2890-P	CONTROL VALVE, 195A-A
4	2	1866-P	WASHER, 1/4 USS 3/4 OD
5	2	1714-P	HHCS, 1/4-20 X 3/4 GR2
6	1	4196M-P	OVERHEAD WELD, 195AM-A
7	1	1473-P	NUT, LOCK, 5/8-11 REV HEX
8	1	565-P	HHCS, 5/8-11 X 4-1/2 GR5
9	1	2854-P	IDLER ARM W/ BEARINGS, 195A
10	1	570-P	COLLAR, 1-1/2" ID
11	2	560-P	BEARING, 1-1/2" ID X 2", GR
12	1	4201M-P	SADDLE ASM, 195AM-A
13	2	540-P	WASHER, 1-1/2 SAE FL 3" OD
14 *	1	726M-P	HINGE PLATE CPT, 1/4" SR
15	1	4200M-P	SADDLE WELD, 195AM-A (NOT SOLD SEPARATELY)
16	1	1296-P	HHCS, 1/4-20 X 7-1/2 GR5
17	1	1297-P	NUT, LOCK, 1/4-20 REV HEX
18	1	168-P	PAWL, WITH DRILLED HOLE
19	1	169-P	SPRING, PAWL
20	1	170-P	SCREW, SHOULDER, 3/8 DIA X 5/8
21	1	710-P	RETAINER, RATCHET PUSH ON 3/4"
22	1	165SS-P	RATCHET, STEEL-IT
23	1	4409-P	GRIP, HANDLE 7/8" X 4-3/4" RED
24	1	165KITM-P	KIT, RATCHET TIGHTENER, SR
25	1	E14SS	FIBRE DRUM STRAP, SS, SR
26	1	4081-P	NUT, ESNA, M8, 8MM
27	1	525-P	KEY, WOODRUFF, SIZE F, ASA1211
28	1	4079-P	HHCS, M8 X 60 MM GR5, 8MM
29	2	1644-P	WASHER, 1/2 SPLIT LOCK
30	2	1502-P	HHCS, 7/16-14 X 1-1/4 GR5
31	1	4067-P	SPEED REDUCER, 195, HELICAL
32	1	3652-P	PLUG, SPEED REDUCER, GR SERIES
33	4	535-P	HHCS, 3/8-16 X 1-1/4 GR5
34	4	1474-P	WASHER, 3/8 SPLIT LOCK
35	1	290-A-P	MOTOR, 1HP, AIR, 56C
36	2	4009-P	ADAPTOR PIPE FIT, 1/4-3/8 195A
37	1	2891-P	HOSE, 12', SELF COILING 195A-A
* Recommended spare parts			

Parts Diagram for Morse Spark Resistant Kontrol-Karrier with Air Power Tilt
Model 195AM-A
Serial Number 224429 to 237662

