

Parts List and Diagram for Morse Kit 2523-P

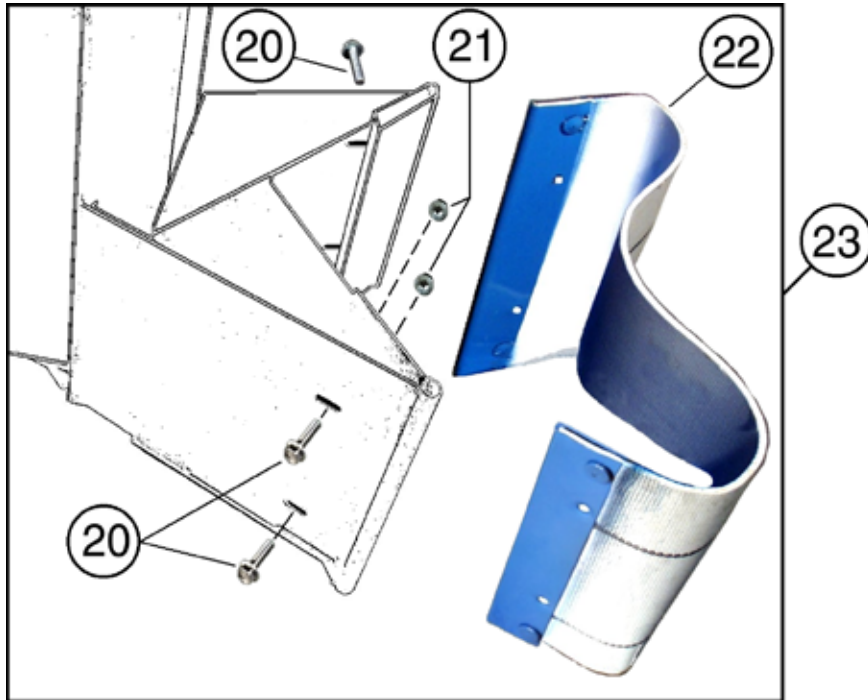

ITEM	QTY *	PART #	DESCRIPTION
20	4	1635-P	5/16 - 18 X 1-1/4 WHIZ SCREW
21	4	1634-P	5/16 - 18 WHIZ - LOCK NUT
22	1	2522-P	BELT ASM, MORSPEED BACKREST
23	1	2523-P	BELT KIT, MORSPEED BACKREST

* Order two Belted Backrest Kits for double drum handlers (model 288-2 or model 288-2-2H), one for each drum position.