

CONTENTS

	Page
Receiving Procedures.	1
Warranty.	1
Safety Information.	1 - 2
Machine Description.	3 - 4
Accessories.	3
Operating Instructions.	4
Maintenance.	5
Dimensions to Calculate Lost Load.	5
Parts Lists and Diagrams.	6 - 7

Operator’s Manual
for Morse Forklift-Karrier
Model 285A

Serial Number 420550 to _____

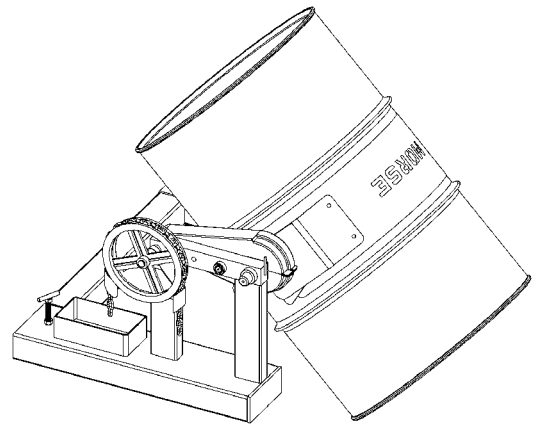
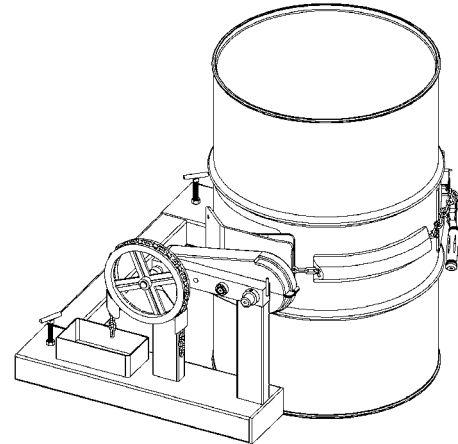

Receiving Procedures

Every Morse drum handler is inspected prior to shipping. However, damage may be incurred during transit.

- Check for visible damage. If you choose to accept damaged freight, always sign noting the damage on the **BILL OF LADING**.
- Document the damage and have the truck driver sign. We recommend keeping a digital camera at your receiving dock for this purpose.
- Open packages expeditiously to check the condition of the goods. There is only a 24 hour window to notify the carrier of any concealed damage.
- **IMMEDIATELY REPORT ALL DAMAGE TO THE SHIPPING COMPANY!** Then you may contact Morse for assistance with your freight claim.
- Morse Manufacturing will not be held responsible for any damaged freight that is not signed for as damaged.

Delivery to non-business addresses without a loading dock result in additional freight charges. Residential delivery fees, inside delivery fees, re-delivery charges, and lift gate services will be added by the truck line, and are non-negotiable.

Limited 2 Year Warranty

Morse drum handling equipment is guaranteed against defects in workmanship or materials for **TWO YEARS** when used properly within its rated capacity. Warranty does not cover wear from normal use or damage from accident or abuse. Motors and other purchased parts carry the warranties of their manufacturers.

For warranty claims, contact your Morse Dealer to obtain a return authorization number, and for return freight advice. Return freight must be prepaid.

In all instances, liability is limited to the purchase price paid or to repairing or replacing the product. Customer assumes liability for any modifications, unauthorized repairs or parts substitution.

Safety Information

While Morse Manufacturing Co. drum handling equipment is engineered for safety and efficiency, a high degree of responsibility must be placed upon the machine operator to follow safe practices, based primarily on common sense, upon which true safety depends.

Failure to follow the safety precautions in this manual can result in personal injury or property damage. Observe the same precautions as with similar machinery where carelessness in operating or maintenance is hazardous to personnel. Carefully read the safety precautions below and throughout this manual.

Operator's Manual for Morse Forklift-Karrier Model 285A
Serial Number 420550 to _____

Safety Information (continued)

 **DANGER** - Indicates a situation which, if not avoided, will result in serious injury or death. This signal word is limited to the most extreme situations.

 **WARNING** - Indicates a situation which, if not avoided, could result in serious injury or death.

 **CAUTION** - Indicates a situation which, if not avoided, can result in damage to the machine.



WARNING - The Forklift-Karrier is designed to handle one drum of the types listed at the top of page 3. Machine Description. **DO NOT** attempt to handle any other type of drum or object. **DO NOT** exceed the weight capacity of 800 Lb. (363 kg). Exceeding these ratings is unsafe and could result in equipment damage, excessive wear or awkward handling.



WARNING - Do Not Modify the Unit. Under no circumstances should any modifications be made to the Morse machinery without factory authorization. Any modifications may void the warranty. This machine was designed to perform a specific job and alterations may result in injury to operator or machine.



WARNING - No Loose Fitting Clothing. Wear close-fitting clothing and safety equipment appropriate to the job. Loose fitting clothing may become caught on the machinery and cause severe personal injury.



CAUTION – Do Not Transport with Drum Raised. Always lower the drum holder to lowest position before transporting.



CAUTION - Wear safety shoes with non-slip soles and hard toe protection.



CAUTION: **DO NOT** allow drum to impact on floor, ground, or dumping station, etc.



WARNING: This product can expose you to chemicals including barium sulfate, cobalt, titanium dioxide, and 2-methylimidazole, which are known to the State of California to cause cancer, and bisphenol-A, which is known to the State of California to cause birth defects or other reproductive harm. For more information go to www.P65Warnings.ca.gov

Operator's Manual for Morse Forklift-Karrier Model 285A
Serial Number 420550 to _____

Machine Description

Model 285A Forklift-Karrier is designed to lift, transport, and dispense a ribbed 55-gallon (210 liter) steel or fiber drum 22" to 23.5" (56 to 59.7 cm) in diameter.

Maximum full-drum capacity is 800 Lb. (363 kg). Capacity is derated to 500 Lb. (227 kg) for a half-full drum. Half-full rating is based on the tilt mechanism's capacity for handling an unbalanced bottom-heavy drum.

MORSE
Mfg. Co., Inc.
E. Syracuse, NY

The Specialist
in Drum
Handling
Equipment

800 Lb.
(363 kg)

Max.
Capacity

Made in U.S.A.

ACCESSORIES

to Install on EXISTING Manual Tilt Drum Handler

55/30 Series Diameter Adapters for drum with diameter smaller than 22" (56 cm). To handle a smaller drum, insert the correct size Diameter Adapter into the standard drum holder. See Diameter Adapter info at:

<https://morsedrum.com/products/diameter-adapters>

ONLY Diameter Adapters for drum with 17.5" (44.5 cm) diameter or smaller have integrated brackets to prevent drum slipping length-ways.

NOTE: For 30-gallon (114 Liter) PLASTIC drum, insert Diameter Adapter; **AND** install Bracket or Top Rim Clamp to prevent drum slipping.

IMPORTANT: To prevent 30 to 55 gallon (114 to 210 L) size plastic drum from slipping, you **MUST** install either Top Rim Clamp Kit or Bracket Assembly Kit.

- 1. Bracket Assembly Kit # 4556-P** is required to handle a RIMLESS plastic drum (figure 2.1), and is also recommended for a fiber drum. The Bracket adjusts for a 31" to 39" (79 to 99 cm) tall drum. You can also handle a rimmed drum with the Bracket installed.
- 2. Top Rim Clamp Kit # 4560B-P** to handle a RIMMED plastic drum (figure 2.2). Install the Top Rim Clamp Kit to handle a RIMMED plastic, steel or fiber drum with suitable top rim.

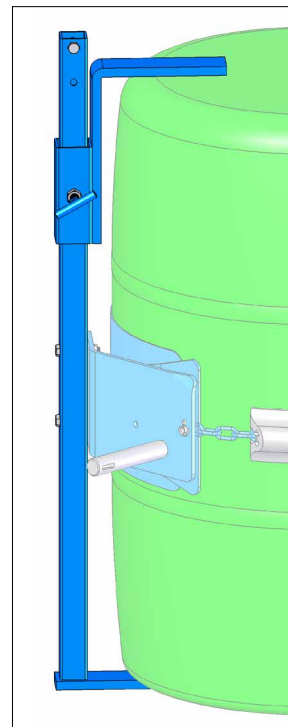

Figure 2.1

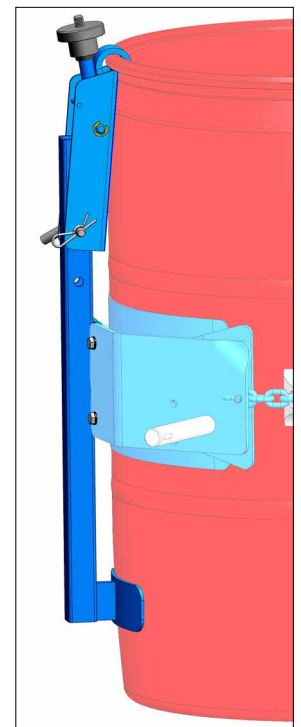
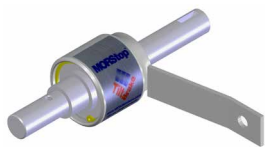
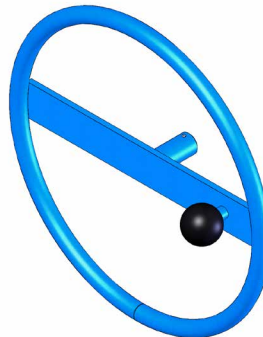

Figure 2.2

Kit # 3900-P
MORStop™ Tilt-Brake
Automatically holds drum tilt angle until you move it.



Kit # 2690-P
Hand Wheel
16" (40.6 cm) diameter Hand Wheel with speed knob. Replaces standard pull chain to turn drum.



Kit # 4556-P
Bracket Assembly
to handle RIMLESS or RIMMED plastic drum

Kit # 4560B-P
Top Rim Clamp
to handle RIMMED plastic drum

Operator's Manual for Morse Forklift-Karrier Model 285A
Serial Number 420550 to _____

Important

1. Please read all instructions thoroughly before attempting to operate your new Morse drum handler.
2. When loading, unloading, operating, or maintaining your MORSE drum handler, always use care and good judgment. Maintain secure footing and a firm hold. Keep hands and loose clothing away from all moving parts. Never allow anyone to be below any part of a raised drum handler or drum. Read operating instructions and review pictures in the sales brochure before operation.
3. This model is a front-end attachment for a forklift, OSHA recommends that "... the truck (forklift) be marked to identify attachment(s) and show approximate weight of truck and attachment combination at maximum elevation with load laterally centered." See center of gravity dimensions on page 5 for calculating lost load on your equipment.

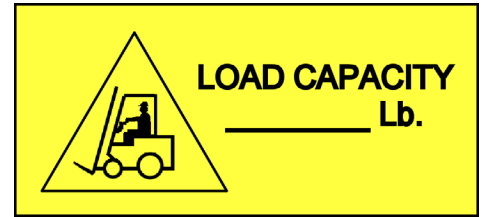

Operating Instructions

1. Before sliding forklift forks into fork tubes, adjust forks to inside spread of 25" (63.5 cm) minimum. Lock forks into position on forklift carriage.
2. Drive forklift forward to slip forks into fork tubes. Tighten tee screws (item #8) to secure Forklift Karrier to forks.
3. Release cinch chain (item #112) and hang loose end from upright peg on front of gear block. Swing ratchet hinge plate to open position.
4. Drive forklift with Forklift Karrier near floor level to position drum holder (saddle) band around middle of drum between ribs.
5. Drape cinch chain across front of drum and insert one link into notch on ratchet handle (shown right). Turn ratchet handle clockwise to tighten cinch chain around drum.
6. Remove pull chain (item #11) from chain box on base frame and place end of loop near operator's seat.
7. Raise forks to clear floor and transport drum in vertical position to dispensing location.
8. To pour drum: pull on chain (item #11), rotating drum to angle required for dispensing. To control pouring angle of drum, pay out one side of chain and pull the other side to prevent drum from free-wheeling.
9. If Forklift-Karrier is equipped with MORStop Tilt-Brake, there is no need to hold tension on both sides of chain loop. Braking is immediate and self-actuating, without additional steps by the operator. To add MORStop Tilt-Brake to your Forklift-Karrier, order kit for field installation (Kit # 3900-P).
10. When dispensing is completed, rotate drum back to vertical and return drum. While transporting, ensure that drum is raised away from floor to prevent drum bottom from interfering with a pallet or other obstacle.

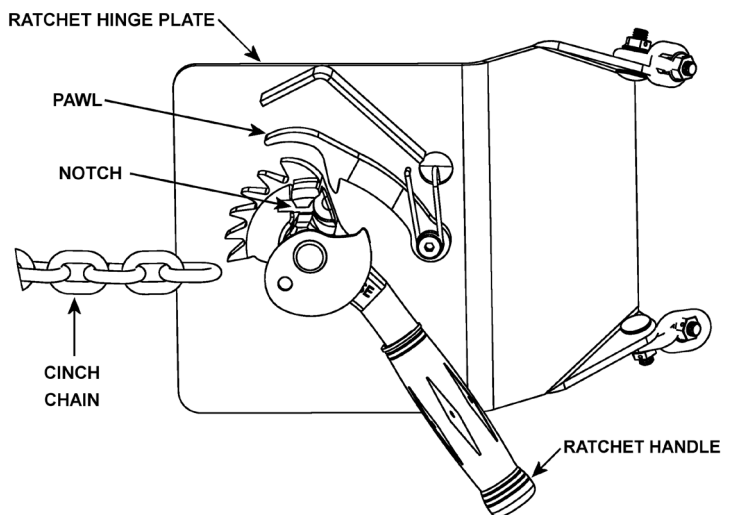
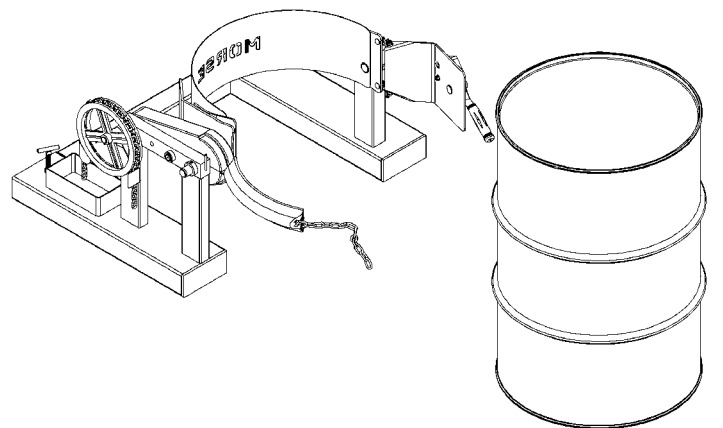
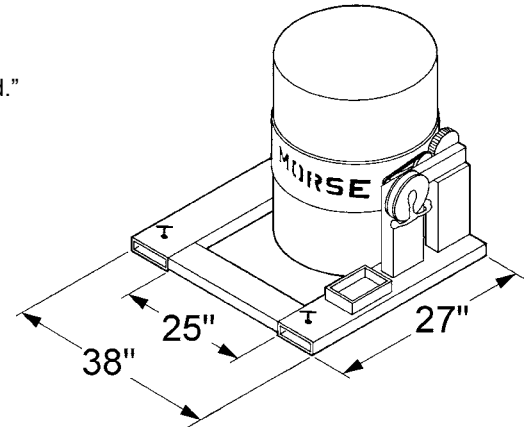

Operator's Manual for Morse Forklift-Karrier Model 285A
Serial Number 420550 to _____

Maintenance

Periodic inspection for the general condition of structural and mechanical components is imperative for safe and efficient operation.

1. Lubricate gear teeth and roller chain.
2. Clean and oil ratchet, pawl and other moving parts periodically. Clean and lubricate more often in environments where dust, dirt or other foreign particles will effect the performance of moving parts.
3. Periodically inspect all moving parts, framework, drum holder and contact areas for signs of wear, fatigue, or loosening. Tighten, adjust, or replace parts as necessary to prevent failure and maintain proper function.
4. Worn or damaged parts must be properly replaced with the correct, genuine Morse parts.

MORSE MODEL 285A

Center of gravity shown for Morse attachment combined with max drum: 958lb [435kg]
(Applies to models: 285A, 285AM, 285G approx net weight 149lb)

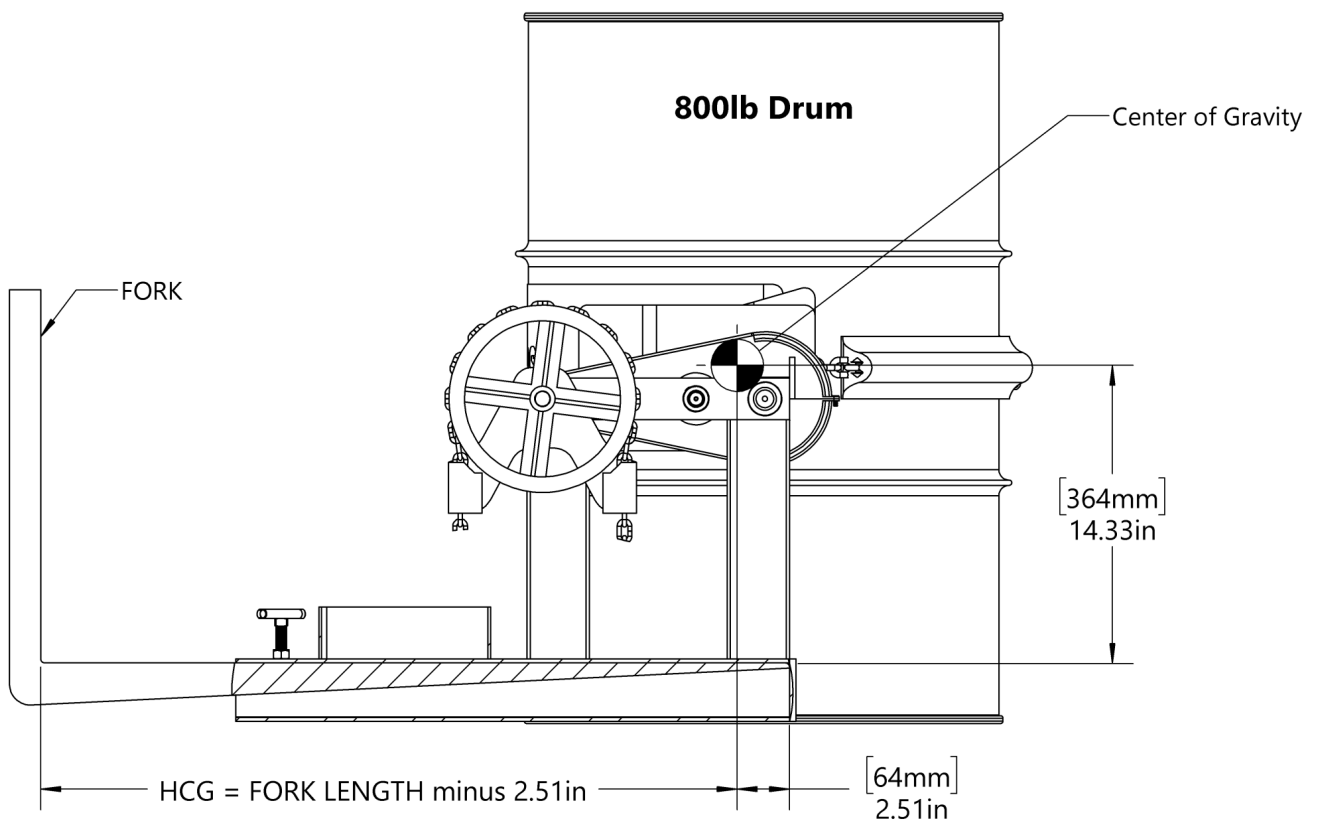

(DIMENSIONS ASSUME FORKS ARE TOUCHING FORK TUBE END CAPS.)

Operator's Manual for Morse Forklift-Karrier Model 285A Serial Number 420550 to _____

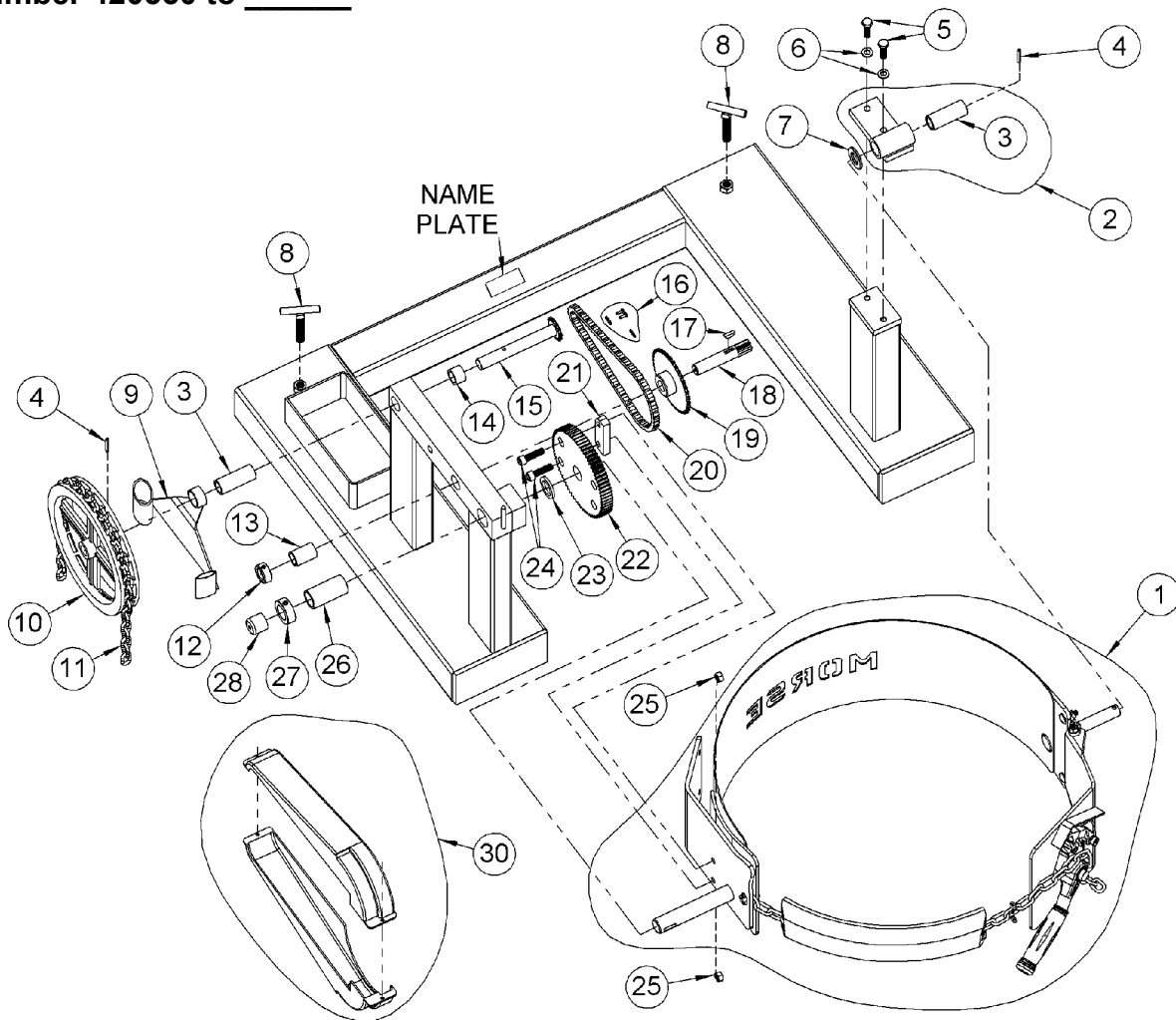

ITEM	QTY.	PART #	DESCRIPTION
1	1	5000-P	SADDLE ASM, MORCINCH, MOR
2*	1	3849B-P	BEARING BLOCK, SLIDING IDLER
3*	2	19-P	BEARING, 3/4" ID X 2-1/2"
4*	2	64-P	ROLL PIN, 3/16 X 1-1/4
5	2	535-P	HHCS, 3/8-16 X 1-1/4 GR5
6	2	1474-P	WASHER, 3/8 SPLIT LOCK
7	1	55-P	WASHER, 3/4 SAE FL 1-1/2 OD
8	2	58-P	SET SCREW, LOCK TEE, 285
9*	1	1304-P	GUIDE, POCKET CHAIN WHEEL
10*	1	1303-P	POCKET CHAIN WHEEL, 3/4 BORE
11*	1	3-285-P	CHAIN, PULL, POCKET 20' LENGTH
12	1	15-P	COLLAR, 3/4" ID
13*	1	7-P	BEARING, 3/4" ID X 1-1/2"
14*	1	1411-P	SPACER, SHAFT W/ 12T SPROCKET
15*	1	1302-P	SHAFT W/ 12T SPROCKET, POCKET

ITEM	QTY.	PART #	DESCRIPTION
16	1	795-P	LINK, MASTER, #35 CHAIN
17*	1	735-P	KEY, WOODRUFF, SIZE 9, ASA606
18*	1	14-P	GEAR, PINION, 7 TOOTH
19*	1	13-P	SPROCKET #35 36T, 3/4" BORE
20*	1	12-P	CHAIN, ROLLER, #35 W/ M LINK
21	1	4473-P	SPACER, SPUR GEAR, MOR
22*	1	23-P	GEAR, SPUR, 72T, 1" HOLE
23	1	29-P	SPACER, SPUR GEAR .15"
24	2	4370-P	SHCS, 3/8-16 X 1-3/8
25	2	1169-P	NUT, 3/8-16 REV HEX LOCK
26*	1	18-P	BEARING, 1" ID X 2-1/2"
27	1	16-P	COLLAR, 1" ID
28	1	4235-P	CAP, PLASTIC, DRIVE SHAFT
29	2	2182-P	WIRE / CABLE TIE, 4-33/64 (NOT SHOWN)
30	1	4285-P	COVER SET, 30:1 GEARS, REG

* Recommended spare parts.

Operator's Manual for Morse Forklift-Karrier Model 285A
Serial Number 420550 to _____

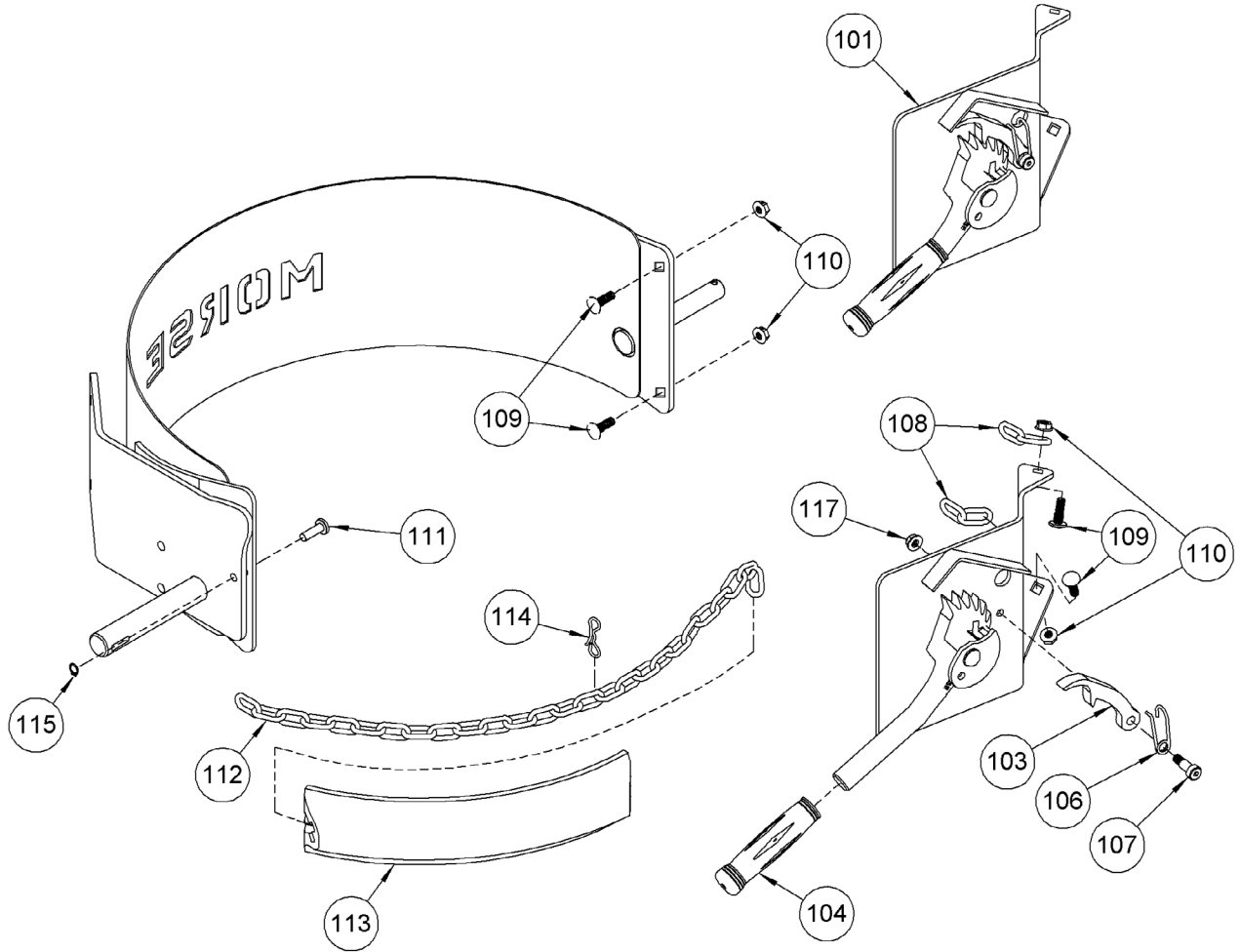

ITEM	QTY.	PART #	DESCRIPTION
101*	1	6871A-P	RATCHET PLATE CPT, SQ HOLE
103	1	168-P	PAWL, WITH DRILLED HOLE
104	1	136-P	GRIP, HANDLE 7/8" X 4-3/4"
106	1	169-P	SPRING, PAWL
107	1	170-P	SCREW, 3/8 DIA X 5/8 SHOULDER
108*	2	5019-P	CHAIN, HINGE, 9/32 ALLOY 2 LK
109*	4	6833-P	BOLT, 5/16-18 X 1 GR5 CAR

ITEM	QTY.	PART #	DESCRIPTION
110*	4	4178-P	NUT, 5/16-18 FLANGE LOCK, MOR
111*	1	4172SP-P	PIN, S.P., CINCH CHAIN, 5000-P
112*	1	5017-P	CHAIN, CINCH, 9/32, 38 LINK
113*	1	4414-P	COVER, CINCH CHAIN, FLEX PVC
114	1	4710-P	PIN, BOW TIE COTTER, MOR
115*	1	4744-P	SNAP RING, EXTERNAL, 3/8"
117	1	1634-P	NUT, 5/16-18 WHIZ LOCK

* Recommended spare parts.