

**Contents**

	Page
Receiving Procedures. . . . .	1
Warranty. . . . .	1
Safety Information. . . . .	1 - 2
Machine Description. . . . .	3
Assembly Instructions. . . . .	3
Operating Instructions. . . . .	4
Maintenance. . . . .	4
Calculating Lost Load. . . . .	5
Parts List and Diagram. . . . .	6

**Operator's Manual**  
**for Morse Extra Heavy-Duty**  
**Forklift-Karrier**  
**Model 285XGR**

Serial Number 0108 to 1209 (MMYY)

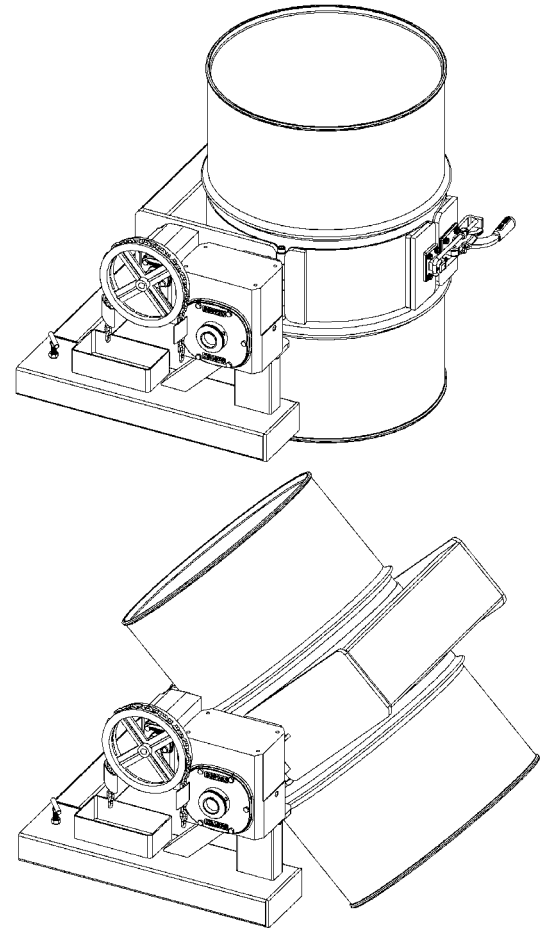

**Receiving Procedures**

Every Morse drum handler is inspected prior to shipping. However, damage may be incurred during transit.

- Check for visible damage. If you choose to accept damaged freight, always sign noting the damage on the **Bill of Lading**.
- Document the damage and have the truck driver sign. We recommend keeping a digital camera at your receiving dock for this purpose.
- Open packages expeditiously to check the condition of the goods. There is only a 24 hour window to notify the carrier of any concealed damage.
- Immediately **report all damage to the shipping company!** Then you may contact Morse for assistance with your freight claim.
- Morse Manufacturing will not be held responsible for any damaged freight that is not signed for as damaged.

**Limited 2 Year Warranty**

Morse drum handling equipment is guaranteed against defects in workmanship or materials for two years when used properly within its rated capacity. Warranty does not cover wear from normal use or damage from accident or abuse. Motors and other purchased parts carry the warranties of their manufacturers.

For warranty claims, contact your Morse Dealer to obtain a return authorization number, and for return freight advice. Return freight must be prepaid.

In all instances, liability is limited to the purchase price paid or to repairing or replacing the product. Customer assumes liability for any modifications, unauthorized repairs or parts substitution.

**Safety Information**

While Morse Manufacturing Co. drum handling equipment is engineered for safety and efficiency, a high degree of responsibility must be placed upon the machine operator to follow safe practices, based primarily on common sense, upon which true safety depends.

Failure to follow the safety precautions in this manual can result in personal injury or property damage. Observe the same precautions as with similar machinery where carelessness in operating or maintenance is hazardous to personnel. Carefully read the safety precautions below and throughout this manual.

#### Operator's Manual for

Morse Extra Heavy-Duty Forklift-Karrier with 2500 Lb. Capacity - Model 285XGR  
Serial Number 0108 to 1209 (MMYY)

#### Safety Information (continued)



**DANGER** - Indicates a situation which, if not avoided, will result in serious injury or death. This signal word is limited to the most extreme situations.



**WARNING** - Indicates a situation which, if not avoided, could result in serious injury or death.



**CAUTION** - Indicates a situation which, if not avoided, can result in damage to the machine.



**CAUTION** – Do Not Transport with Drum Raised. Always lower the drum holder to lowest position before transporting.



**WARNING** - The Forklift-Karrier is designed to handle one drum of the types listed at the top of page 3. Machine Description. DO NOT attempt to handle any other type of drum or object. DO NOT exceed the weight capacity of 2500 Lb.



**WARNING** - Do Not Modify the Unit.

Under no circumstances should any modifications be made to the Morse machinery without factory authorization. Any modifications may void the warranty. This machine was designed to perform a specific job and alterations may result in injury to operator or machine.



**WARNING** - No Loose Fitting Clothing

Wear close-fitting clothing and safety equipment appropriate to the job. Loose fitting clothing may become caught on the machinery and cause severe personal injury.



**CAUTION** - Wear Safety Shoes

Wear safety shoes with non-slip soles and hard toe protection.



**CAUTION:** DO NOT allow drum to impact on floor, ground, or dumping station, etc.

## Operator's Manual for

**Morse Extra Heavy-Duty Forklift-Karrier with 2500 Lb. Capacity - Model 285XGR**  
**Serial Number 0108 to 1209 (MMYY)**

## Machine Description

The Model 285XGR Extra Heavy-Duty Forklift-Karrier is designed to lift, transport, and dispense a ribbed 55-gallon steel drum 22.5" in diameter. The maximum full-drum capacity is 2500 Lb. The capacity is derated to 1250 Lb. for a half-full drum. The half-full rating is based on the tilt mechanism's capacity for handling an unbalanced bottom-heavy drum.



## Assembly Instructions

1. Remove the following items from the small cardboard box packaged with the 285XGR: chain wheel, chain guide w/ pull chain, bushing, 3/16 square key (items 2-6).
2. Slide bushing (item 4) and chain guide w/ pull chain (items 3 and 5) onto speed reducer (item 7) input shaft with the chain guide facing outward as pictured in parts diagram.
3. Insert 3/16 square key (item 6) into the key way on the input shaft of the speed reducer. Slide the key up to the bushing.
4. While raising the pull chain up into a loop, slide the chain wheel onto shaft with the keyway in the chain wheel lined up with the square key. Lay the loop of pull chain into the pockets in the chain wheel. Tighten the two set screws on the hub of the chain wheel.
5. Install speed reducer oil vent plug and check oil level as shown in the speed reducer owners manual.
6. Prior to initial use, inspect all moving parts and test rotation of chain wheel and saddle assembly. Perform necessary load test, inspections, operator training, etc.

## Important

1. Review the Material Safety Data Sheet(s) for the material(s) in the drum(s) and take all necessary precautions. Safety shoes, work gloves, hard hat and other personal protective devices are recommended.
2. Please read all instructions thoroughly before attempting to operate your new Morse drum handler.
3. The model 285XGR has a maximum capacity rating of 2500 Lb. full drum and 1250 Lb. half-full drum and is designed to lift, move and pour a 55-gallon steel drum. DO NOT exceed these ratings. Exceeding these ratings or handling drums other than those mentioned above is unsafe and could result in equipment damage, excessive wear or awkward handling.
4. When loading, unloading, operating, or maintaining your MORSE drum handler, always use care and good judgment. Maintain secure footing and a firm hold. Keep hands and loose clothing away from all moving parts. Never allow anyone to be below any part of a raised drum handler or drum. Read operating instructions and review the pictures in the sales brochure before operation.
5. Because the model 285XGR is a front-end attachment for a forklift, OSHA recommends that "... the truck (forklift) be marked to identify the attachment(s) and show the approximate weight of the truck and attachment combination at maximum elevation with load laterally centered." See center of gravity dimensions of model 285XGR on page 5 for calculating lost load on your equipment.
6. Prior to initial use, inspect all moving parts and test rotation of chain wheel and saddle assembly. Inspect saddle assembly for proper operation. Perform necessary load test, inspections, operator training, etc.

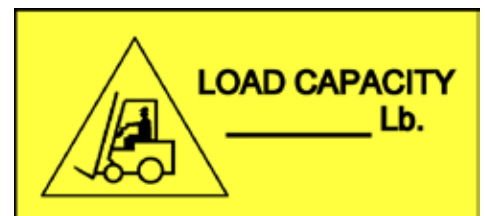

**Operator's Manual for**  
**Morse Extra Heavy-Duty Forklift-Karrier with 2500 Lb. Capacity - Model 285XGR**  
**Serial Number 0108 to 1209 (MMYY)**

**Operating Instructions**

1. Before sliding forklift forks into the fork tubes, adjust forks to an inside spread of 24.5" minimum. Lock forks into position on the forklift carriage.
2. Drive the forklift forward to slip the forks into the fork tubes (see item 29). Tighten tee screws (item 13) to secure the Forklift Karrier to the forks. Transport Forklift Karrier to drum to be handled.
3. Drive the forklift with the Forklift Karrier near floor level to position the saddle band around the middle of the drum between the ribs.
4. Open the toggle clamp by activating the release lever (item 25) and swing both hinge bands to the open position. Push the Forklift-Karrier against the drum to surround the drum with the saddle band.
5. Close the two hinged bands around the drum and latch the toggle clamp to secure the drum.
6. Remove pull chain (item 5) from chain box on base frame (item 29) and place end of loop near operator's seat.
7. Raise forks to clear the floor and transport drum in vertical position to dispensing location.
8. To pour drum: pull on chain (item 5), rotating drum to angle required for dispensing. To control the pouring angle of the drum, pay out one side of chain and pull the other side to prevent the drum from free-wheeling.
9. When dispensing is completed, rotate the drum back to vertical and return drum. While transporting, ensure that the drum is raised away from the floor to prevent the drum bottom from interfering with a pallet or other obstacle.
10. Remove the drum by activating the release lever and opening the toggle clamp. Swing both hinged bands open. Drive the forklift away from the drum.

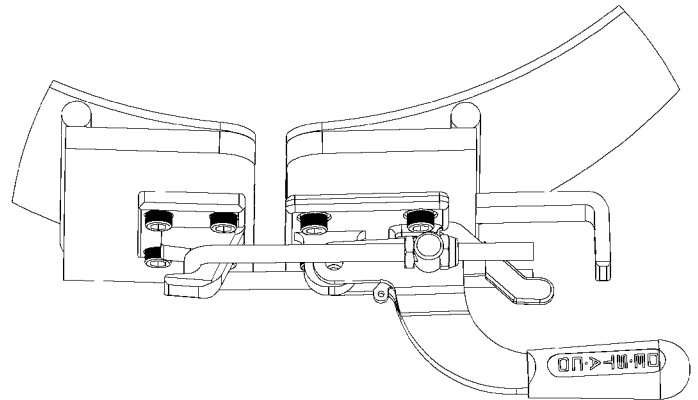
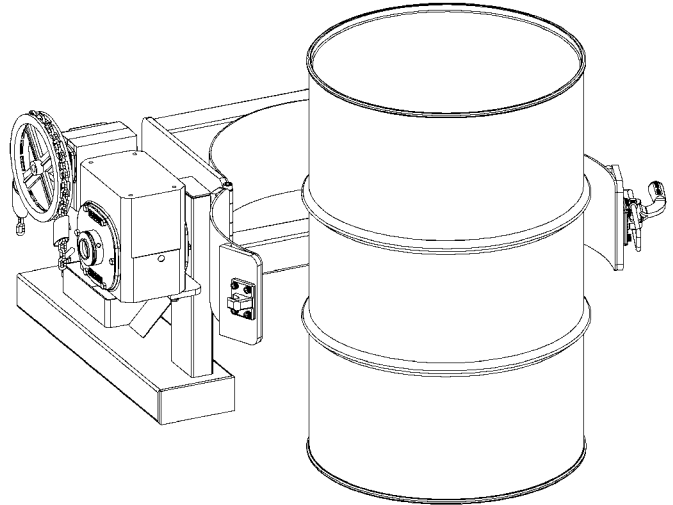

**Maintenance**

Periodic inspection for the general condition of structural and mechanical components is imperative for safe and efficient operation.

1. Inspect oil level in speed reducer.
2. Periodically inspect all moving parts, framework, drum holder and contact areas for signs of wear, fatigue, or loosening. Tighten, adjust, or replace parts as necessary to prevent failure and maintain proper function.
3. Oil or grease all moving parts.
4. Worn or damaged parts must be properly replaced with the correct, genuine Morse parts.

**Operator's Manual for**  
**Morse Extra Heavy-Duty Forklift-Karrier with 2500 Lb. Capacity - Model 285XGR**  
**Serial Number 0108 to 1209 (MMYY)**

**CENTER OF GRAVITY DIMENSIONS FOR  
 CALCULATING LOST LOAD ON EQUIPMENT**

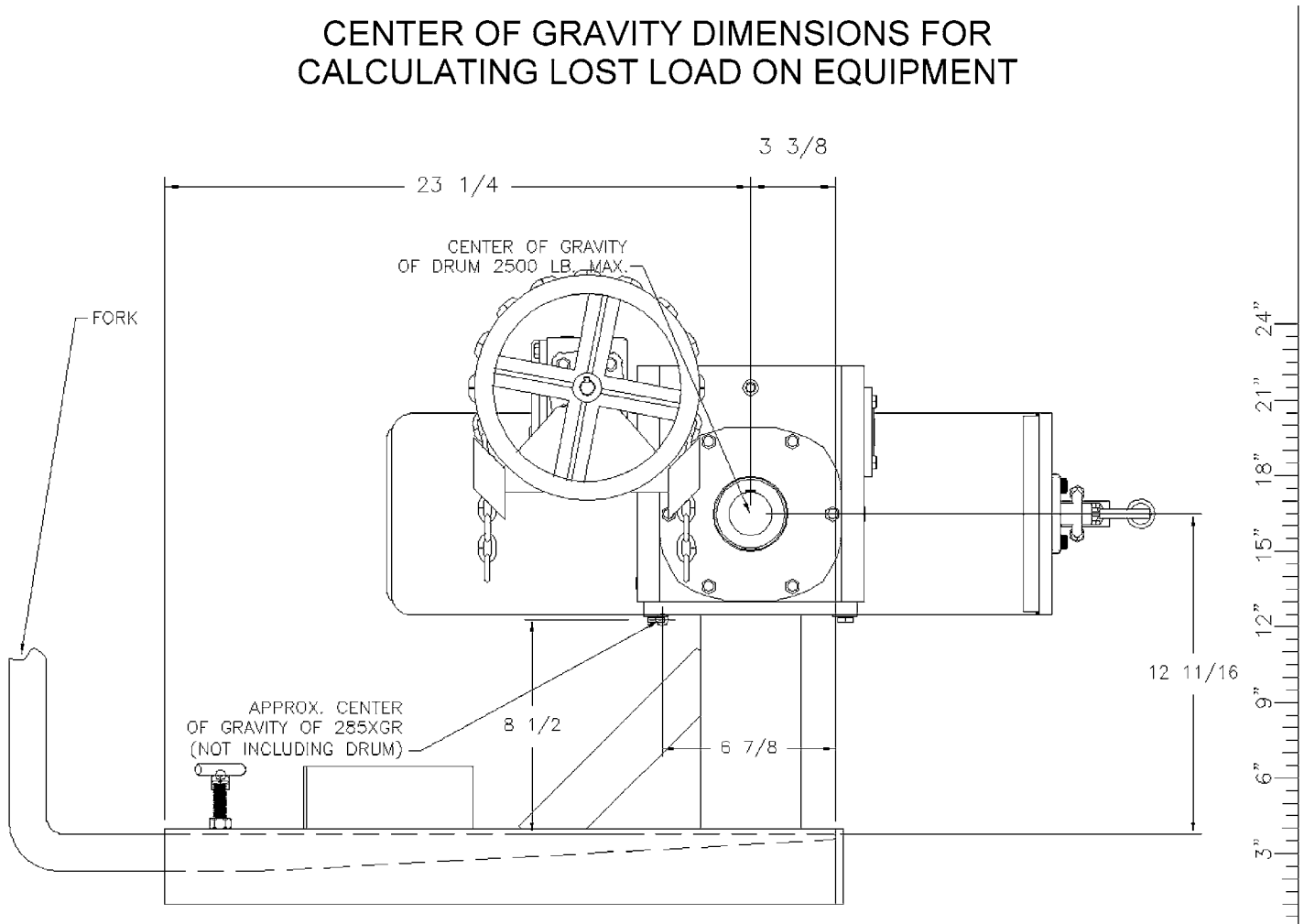

DIMENSIONS ARE MEASURED FROM INSIDE OF FORK TUBE END. THIS WILL GIVE A FIXED POINT TO WHICH LOST LOAD DATA CAN BE DETERMINED. (FORKS MUST BE TOUCHING THIS FORK TUBE END.)

MODEL  
285XGR

NET WEIGHT  
333

OPTION SUBTRACT FROM MODEL  
X03 -9 L.B.

**Operator's Manual for**  
**Morse Extra Heavy-Duty Forklift-Karrier with 2500 Lb. Capacity - Model 285XGR**  
**Serial Number 0108 to 1209 (MMYY)**

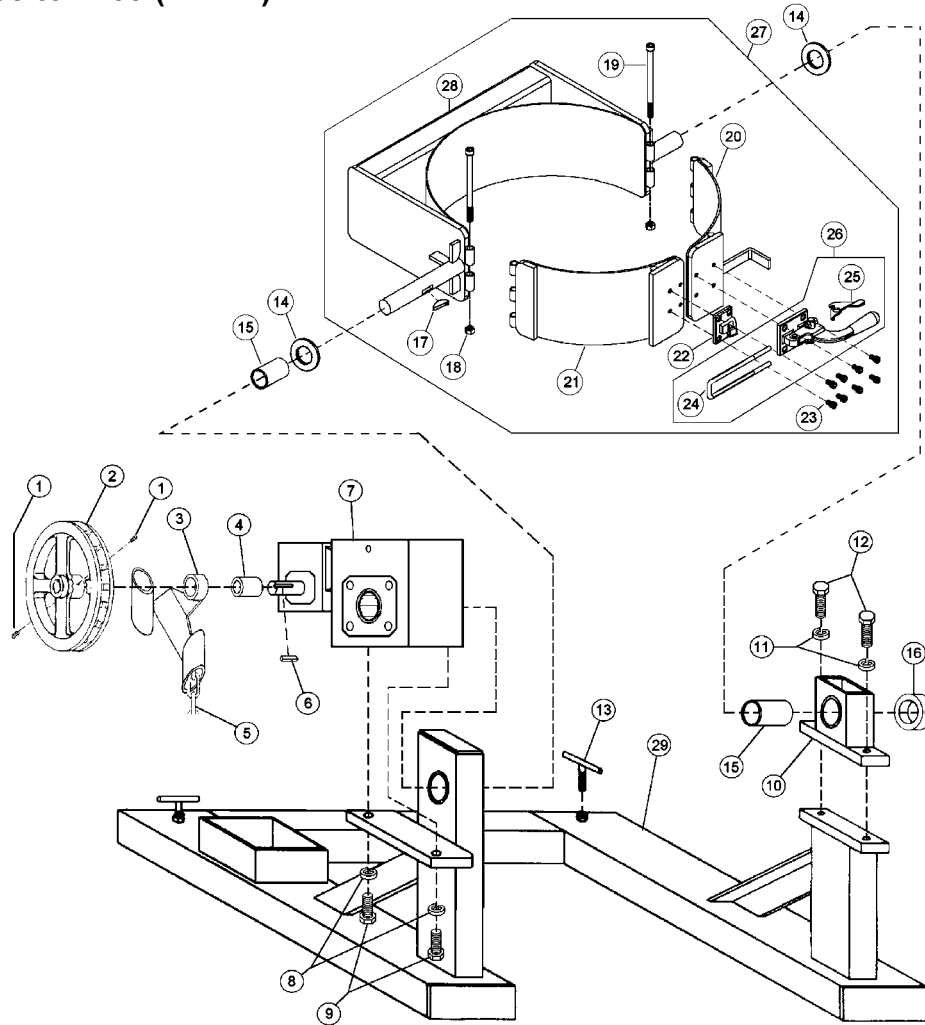

ITEM	QTY	PART #	DESCRIPTION
1	2	1000-P	SET SCREW, 1/4 - 20 X 1/4
2	1	1322-P	POCKET CHAIN WHEEL, 5/8 BORE
3	1	1304-P	GUIDE, POCKET CHAIN WHEEL
4	1	1324-P	BUSHING, 5/8 ID X 1" OD
5	1	3-285-P	PULL CHAIN, POCKET, 20' LENGTH
6	1	1326-P	KEY, SQUARE, 3/16 X 1"
7	1	603-P	SPEED REDUCER, 2 STAGE, 285GR
8	2	1166-P	WASHER, 3/8 USS 1" OD
9	2	1502-P	HHCS, 7/16-14 X 1-1/4 GR5
10	1	595-P	IDLER BEARING ASM, 285GR
11	2	1474-P	WASHER, 3/8 SPLIT LOCK
12	2	535-P	HHCS, 3/8-16 X 1-1/4 GR5
13	2	58-P	SET SCREW, LOCK TEE, 285
14	2	540-P	WASHER, 1-1/2 SAE FL 3" OD
15 *	2	560-P	BEARING, 1-1/2" ID X 2", GR

ITEM	QTY	PART #	DESCRIPTION
16	1	570-P	COLLAR, 1-1/2" ID
17	1	525-P	KEY, WOODRUFF, SIZE F, ASA1211
18	2	810-P	NUT, LOCK, 1/2-13 REV HEX
19	2	3592-P	SHCS, 1/2-13 X 7-1/2
20	1	4516-P	FRONT BAND WELD, CLAMP, XGR
21	1	4515-P	FRONT BAND WELD, CATCH, XGR
22	1	3067-P	CATCH, 375-R TOGGLE, CAMLOCK
23	8	22-P	SHCS, 3/8-24 X 5/8
24	1	4190-P	U-BOLT, 7", 375-R CLAMP
25	1	3601-P	RELEASE LEVER, 2984-P
26 *	1	4187-P	TOGGLE CLAMP, W/ U BOLT
27	1	4511-P	SADDLE ASM, XGR, 3PC, 2500LB
28	1	4512-P	SADDLE WELD, XGR, 2500 LB. (NOT SOLD SEPERATELY)
29	1	590-P	BASE FRAME 285GR W/ BRG

\* Recommended spare parts