

## OPERATOR'S MANUAL FOR "MORSPEED" FORK TRUCK DRUM HANDLER

(If using Model 287 "Carriage Mount with Head" directly on carriage without forks, skip to step 2.)

1. Position forks to proper width to meet the fork sleeve openings of the "Morspeed" Fork Reach Mount. Drive forks into sleeves until they contact far endcaps. Hook the safety chain clamp to top edge of carriage and tighten T-bolt. Take up the slack by engaging a chain link in the notch provided on the top rack angle.
2. Place Carriage Mounts with Heads on cross bars of Fork Reach Mount or onto ITA Class 2 carriage. Space them so the "Morspeed" jaws are approximately one drum diameter center-to-center. For Model 288-1, center the single Carriage Mount with Head.
3. For 55 gallon steel drums, set "Morspeed" Heads in carriage mount so that cross-pin is in the top or second hole. For shorter drums use suitable lower holes. It is always best to keep Vee Backrest as close to the bottom of the drum as possible.
4. Set rake of mast so that when lifted, the "Morspeed" Carriage Mounts are vertical or inclined slightly forward. This setting should be maintained.
5. Approaching the drums for lifting:  
Drive truck with unit low to the floor. Steer to make the Morspeed head meet the drum straight-on at its center-line. The head should push into the side of the drum near the drum top. Morspeed jaws must arrive below the rim of the drum. Operator can gauge the proper height by aligning the top of the head(s) to be about flush with the top of the drum. If necessary, lower the carriage before contacting the drum to assure jaws will be below the rim before lifting.
6. As the "Morspeed" Heads are driven against the drums, the spring loaded parallel links will pivot downward to cushion against the drum. Spring pressure will tend to keep the head(s) forward, in contact with the drum during lifting to assure that the lower jaw catches the rim during the lift.
7. Raise carriage in one steady movement until drums are seen to be properly suspended. Avoid any tendency to interrupt the lift while the "Morspeed" Jaws operate to grab the drum. After very little practice, operations 5, 6, and 7 will be done easily in one flow of action.

**TIP:** It is not necessary to tilt the mast forward or back to effect gripping or releasing.

**TIP:** It is not necessary to have the jaws make first contact with the drum rim. Simply drive them in below the rim and raise. They will engage as the lower jaws catch under the rim as the Morspeed rises.

**TIP:** It is not necessary to tilt the mast backward as you might when handling pallets. If, after the drums are properly lifted, you want to tilt them back to clear other drums, this is permissible. Reset the mast to the original position (with Morspeed upright, drum will tilt forward slightly) before drums are put down and released.

**TIP:** If lifting two drums that are not spotted side by side, it may be necessary to lift one, carry it and put it down next to the other drum. Then both can be picked up together, side by side.

8. Drive the truck to deliver the drums as necessary.

**WARNING:** Once drums are correctly picked-up, they should remain held safely by the "Morspeed" unless the truck is driven fast over a bad ridge or wide crack in the ground. The sudden movement could momentarily unweight the drum, thus allowing the jaws to open. Therefore, good truck discipline should be followed by keeping the load low when moving from place to place and by avoiding unreasonable surfaces and speeds.

9. To release drums, simply lower them until the “Morspeed” Jaws open automatically. Do not stop lowering as soon as drums touchdown, keep going down for a few more inches. Then you can back away.

**TIP: USE OF VEE BACKREST TO POSITION DRUMS:** Drums standing on the floor can be positioned for picking up by tilting the truck mast backward so the “Morspeed” Heads will clear the drums. The Vee Backrest can then be used to push the drums to locate them correctly. To lift drums, return mast to proper position as in Step 4 and Note in Step 8.

#### **POSSIBLE REASONS FOR FAILURE TO PICK-UP:**

- (a) Carriage mounts with Heads not spaced correctly (paragraph 2). (For two drum models)
- (b) Carriage mount not lifting vertically (paragraph 4).
- (c) Truck not being squared up (paragraph 5).
- (d) Truck being allowed to creep backwards after contact with drums has been made.
- (e) Truck driver tilting mast backwards.

#### **POSSIBLE REASONS FOR FAILURE TO RELEASE:**

- (a) Paragraph 9 procedure not being followed.
- (b) Carriage mount not vertical. If mast is tilted backward, the drum may meet the floor leaning backward. As drum settles and tries to return to upright it may pull against inside of the upper jaw “hook” preventing the upper jaw from moving cleanly upward and away to release the drum.

#### **MAINTENANCE:**

Regular lubrication of moving parts is recommended. The “Morspeed” Head should be protected from the weather when not in use. Apply 90W oil generously to all moving joints and spring-anchor points approximately every 500 drum lifting cycles. Apart from replacement of springs, the customer is requested to communicate with the Supplier at once in the unlikely event of defect or breakdown.

***The Manufacturer cannot be held responsible for any consequences if spare parts other than those supplied by them are used.***

#### **MORSE MFG. CO., INC.**

727 West Manlius Street  
P.O. Box 518  
East Syracuse, NY 13057-0518  
Phone: 315-437-8475  
Fax: 315-437-1029 •  
E-mail: [service@morsemfgco.com](mailto:service@morsemfgco.com)  
URL: [www.morsemfgco.com](http://www.morsemfgco.com)

**When ordering parts, specify  
part number and description,  
model number and serial number.  
Find model number and serial number  
on metal tag attached to Morspeed.**

**MORSPEED Model Numbers**



**MODEL 288-0**

Fork Reach Mount assembly which allows the use of MORSPEED on forks. It is not a drum handler by itself.



**MODEL 287**

Has one "head" per drum. Fits directly onto ITA Class 2 carriage without forks. Also mounts onto Model 288-0 to provide ample reach for moving drums to and from pallets or shelves.



**MODEL 287-2H**

Has two "heads" for a single drum. Fits directly onto ITA Class 2 carriage without forks. Also mounts onto Model 288-0 to provide ample reach for moving drums to and from pallets or shelves.



**MODEL 288-1**

Fork mounted model designed to handle one drum with a single head.

**SINGLE HEAD MODELS**



**MODEL 288-2**

Fork mounted model designed to handle two drums, each with a single head.



**MODEL 288-1-2H**

Fork mounted model designed to handle a single drum, gripping it with two heads.

**DOUBLE HEAD MODELS**



**MODEL 288-2-2H**

Fork mounted model designed to handle two drums with two heads per drum.

# MORSPEED

ITEM	MODEL NUMBERS (see note 2)	QUANTITY (see note 1)	PART NUMBER	DESCRIPTION
1	**	1	2635-P	CHAIN ANCHOR TEE, 288-0
2	**	1	288-0	MORSPEED FORK REACH MOUNT
3	**	1*	287	MORSPEED CARRIAGE MT W/HEAD
4	**	1*	2625-P	TIE ROD WELDMENT, 287
5	**	1*	2619-P	TIE ROD HOOK, 287
6	**	1*	17-P	WASHER, 5/8 SAE FL
7	**	1*	2626-P	5/8 - 11 FIN HEX NUT STL
8	**	1*	2624A-P	CARRIAGE MT WELDMENT, 287
9	**	1*	2624-P	CARRIAGE MT W/LOCK W/O HEAD
10	**	1*	913-P	HAIR PIN, PIN RETAINER, 287
11	**	1*	923-P	MORSPEED HEAD ASM
12	**	1*	911-P	LOCK PIN WELDMENT, 287
13	**	1*	923X2-P	MORSPEED DOUBLE HEAD, 1 DRUM
14	**	1*	923CX2-P	BACKREST W/ BOX CPT, 923X2-P
15	**	1*	923AX2-P	DBL HEAD W/O BACKREST, 923X2-P
16	**	4*	1474-P	WASHER, 3/8 SPLIT LOCK
17	**	4*	535-P	3/8 - 16 X 1-1/4 HHCS GR 5 STL
18	287, 288-1	1	927-P	SPRING, MORSPEED, LARGE
18	287-2H, 288-2, 288-1-2H	2	927-P	SPRING, MORSPEED, LARGE
18	288-2-2H	4	927-P	SPRING, MORSPEED, LARGE
19	287, 288-1	1	928-P	BLOCK, SPRING, ANCHOR
19	287-2H, 288-2, 288-1-2H	2	928-P	BLOCK, SPRING, ANCHOR
19	288-2-2H	4	928-P	BLOCK, SPRING, ANCHOR
20	**	4*	1635-P	5/16 - 18 X 1-1/4 WHIZ SCREW
21	(OPTIONAL)	4*	1634-P	5/16 - 18 WHIZ - LOCK NUT
22	(OPTIONAL)	1*	2522-P	BELT ASM, MORSPEED BACKREST
23	(OPTIONAL)	2*	2523-P	BELT KIT, MORSPEED BACKREST
24	287, 288-1	1	926-P	SPRING, MORSPEED, MEDIUM
24	287-2H, 288-2, 288-1-2H	2	926-P	SPRING, MORSPEED, MEDIUM
24	288-2-2H	4	926-P	SPRING, MORSPEED, MEDIUM
25	287, 288-1	1	2973-P	SPRING, MORSPEED, LOW TENSION
25	287-2H, 288-2, 288-1-2H	2	2973-P	SPRING, MORSPEED, LOW TENSION
25	288-2-2H	4	2973-P	SPRING, MORSPEED, LOW TENSION
26	**	1*	921-P	SPRING SET, 1LG, 1MD, 1LT

NOTE 1: \* Quantities are doubled for Model 288-2 or Model 288-2-2H.

NOTE 2: \*\* Indicates part is included in all MORSPEED models in 287 and 288 series.

### MORSPEED

SEE PAGE 6 FOR  
INTERNAL SPRING  
ARRANGEMENT

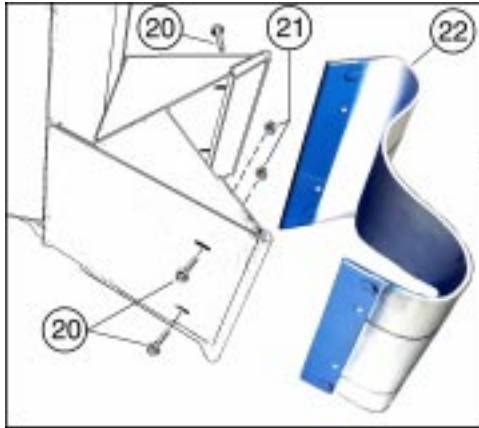

OPTIONAL BELT KIT  
MOUNTS ONTO MODEL 287

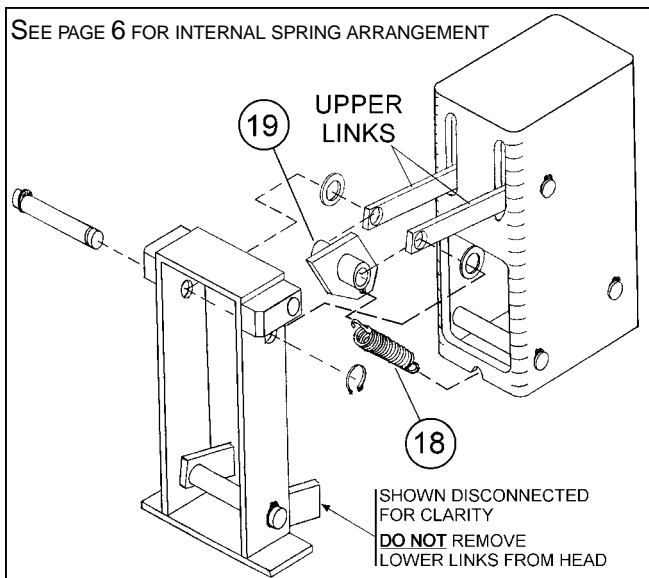
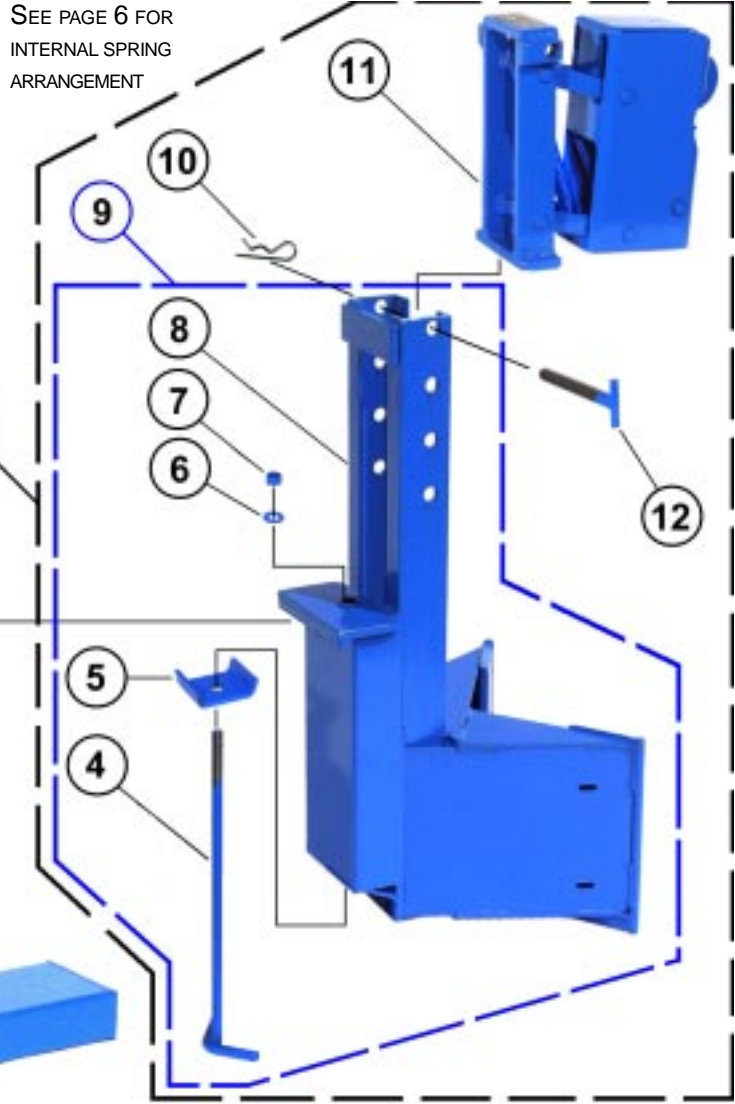
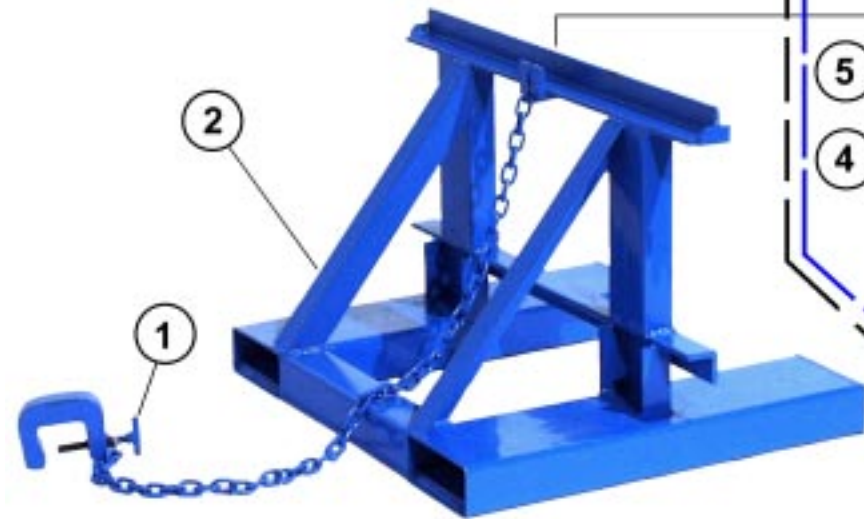

MORSPEED SINGLE HEAD

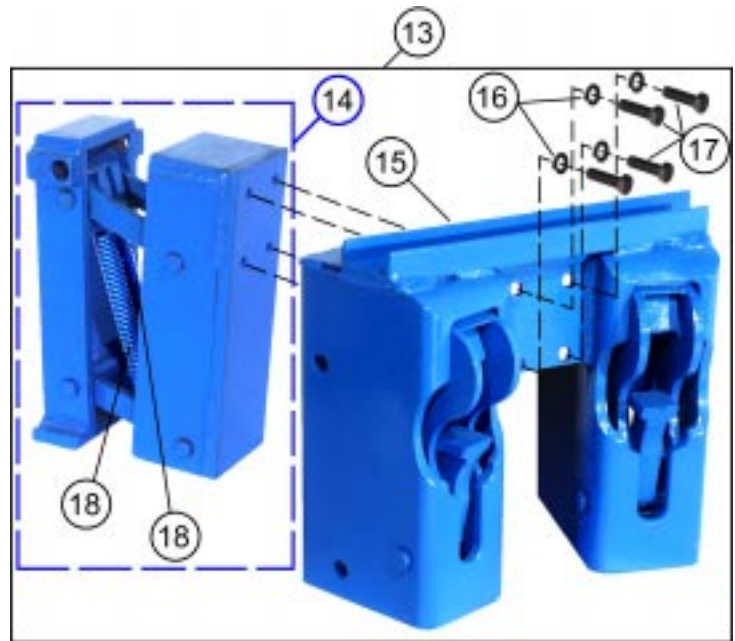

MORSPEED DOUBLE HEAD (Model numbers end with "-2H")

## MORSPEED Head Internal Springs

- P/N 920-P SPRING SET INCLUDED:
  - (2) 926-P MEDIUM (item 24)
  - (1) 925-P SMALL (discontinued)
  - (1) 927-P LARGE (item 18). . . not shown (see page 5)

- P/N 921-P (item 26) SPRING SET INCLUDES:
  - (1) 926-P MEDIUM (item 24)
  - (1) 2973-P LOW TENSION (item 25)
  - (1) 927-P LARGE (item 18). . . not shown (see page 5)

(Prior to 01/99)

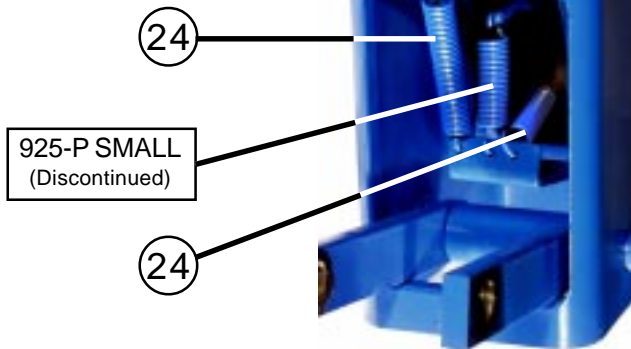

Heads made prior to 01/1999 had Part Number 922-P

(As of 01/99)

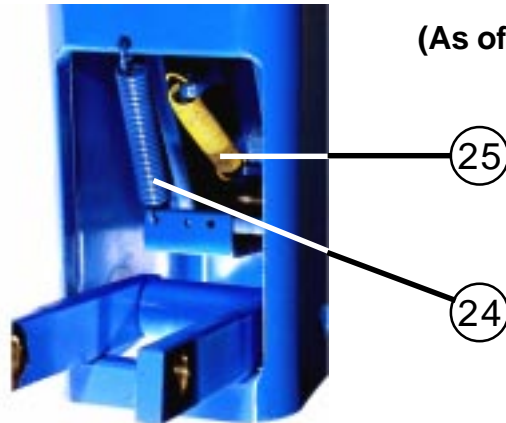

Heads made since 01/1999 have Part Number 923-P

## Factory Service of the **MORSPEED** Heads (item 11 - Part 923-P) Model 288 Series and 287

**MORSPEED Head Has Few User Serviceable Parts.** The mechanism in the head is designed and built for durability with several of its critical moving parts "permanently" retained. The design allows the springs to be replaced. Removal and replacement of some shafts and retainers will be possible to access the springs. Spring replacement may be performed by maintenance personnel on site or in local shops. Repairs other than spring replacement should not be attempted by user. See Factory Rebuilding below.

**Springs Are Recommended Spare Parts.** Morse sells original equipment springs (items 18, 24, 25) and the anchor plate (item 19). See list below. The customer may order and replace these springs as necessary. Some users keep some springs on hand to minimize downtime.

**Factory Rebuilding Service Available** (order Part Number 1090-P). Aside from replacement of the springs, which a customer may do in their own facility, Morse Mfg. recommends that if a head needs repair, it should be sent back to the factory to be serviced or rebuilt. For example, jaws, pins, etc. should be repaired or replaced using the factory service explained below.

**To Have The Head Serviced** the user should contact their Morse Dealer to obtain RGA number (Return Goods Authorization). Ship the head to the address below, freight prepaid. Mark the shipment with the RGA number, your Morse Dealer name, and your return address. Include contact person name, phone and fax numbers, and any explanatory notes about the wear or damage to be fixed.

**Ship Head(s) To:**

Morse Mfg. Co., Inc.  
RGA (show authorization number)  
MORSE DEALER NAME  
727 West Manlius St.  
East Syracuse, NY 13057

Morse will evaluate the head to determine its suitability for repair or recommend replacement. Severely worn or damaged heads may be unsuitable for rebuilding. Morse sells new heads and occasionally has rebuilt heads for sale (part number 1071-P).

Issue A Purchase Order. Morse Mfg. will enable the Morse Dealer to provide a quotation of the repair charges or advice on replacement. User should issue a purchase order to the Morse Dealer for the work to be completed.