

PARTS LIST for WORM GEAR SPEED REDUCER used on

Morse 300 Series and 5154 Series Drum Rotators Serial Number 174638 to _____

Speed Reducers used on End-Over-End Drum Rotators:

Part # 2919-P used on 1-300 Series

Part # 2920-P used on 2-300 Series

Speed Reducers used on 5154 Series Drum Rotators:

Part # 2913-P, 2914-P, 2916-P or 2917-P

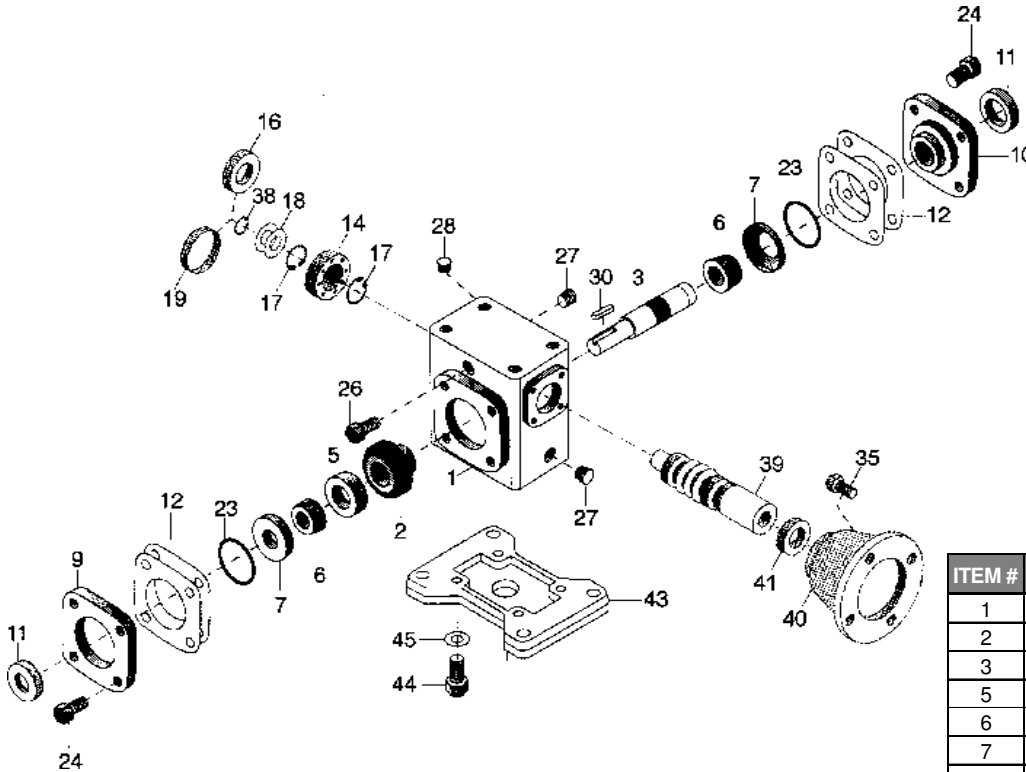

For replacement parts, please contact your Morse dealer.

When ordering parts, please specify:
 - Part number and description,
 - Model number
 - Serial number

Find model number and serial number on metal name plate attached to frame.

ITEM #	DESCRIPTION
1	HOUSING
2	WORM GEAR
3	SINGLE PROJECTING OUTPUT SHAFT
5	GEAR SPACER
6	OUTPUT BEARING (CONE) - MODELS 713-760
7	OUTPUT BEARING (CUP) - MODELS 713-760
9	BEARING CARRIER (OPEN)
10	BEARING CARRIER (CLOSED)
11	OUTPUT OIL SEAL
12	ADJUSTMENT SHIMS
14	INPUT BEARING - MODELS 710-726
16	INPUT OIL SEAL - MODELS 710-726
17	RETAINING RING
18	ADJUSTMENT SHIMS
19	BORE PLUG - MODELS 710-726
23	OUTPUT "O" RING
24	HEX HEAD CAP SCREW (8)
26	VENT PLUG - 2 PIECE
27	PIPE PLUG
28	PROTECTIVE CAP PLUG
30	OUTPUT KEY
35	HEX HEAD CAP SCREW (4)
38	RETAINING RING - MODELS 710-738
39	MOTOR SHAFT - MODELS 710-738
40	MOTOR FLANGE - MODELS 710-738
41	OIL SEAL - MODELS 710-738
43	HORIZONTAL BASE
44	HEX HEAD CAP SCREW
45	LOCKWASHER