

**Contents**

	Page
Receiving Procedures. . . . .	1
Warranty. . . . .	1
Safety Information. . . . .	1 - 2
Machine Description. . . . .	3 - 4
Operating Instructions. . . . .	4 - 5
Maintenance. . . . .	5
Parts Lists and Diagrams. . . . .	6 - 9

**Operator's Manual**  
**for Morse Hydra-Lift Drum Karrier**  
**Model 400A-60-110**

Serial Number 0103 to \_\_\_\_ (MMYY)

**Receiving Procedures**

Every Morse drum handler is inspected prior to shipping. However, damage may be incurred during transit.

- Check for visible damage. If you choose to accept damaged freight, always sign noting the damage on the **BILL OF LADING**.
- Document the damage and have the truck driver sign. We recommend keeping a digital camera at your receiving dock for this purpose.
- Open packages expeditiously to check the condition of the goods. There is only a 24 hour window to notify the carrier of any concealed damage.
- **IMMEDIATELY REPORT ALL DAMAGE TO THE SHIPPING COMPANY!** Then you may contact Morse for assistance with your freight claim.
- Morse Manufacturing will not be held responsible for any damaged freight that is not signed for as damaged.

Delivery to non-business addresses without a loading dock result in additional freight charges. Residential delivery fees, inside delivery fees, re-delivery charges, and lift gate services will be added by the truck line, and are non-negotiable.

**Limited 2 Year Warranty**

Morse drum handling equipment is guaranteed against defects in workmanship or materials for **TWO YEARS** when used properly within its rated capacity. Warranty does not cover wear from normal use or damage from accident or abuse. Motors and other purchased parts carry the warranties of their manufacturers.

For warranty claims, contact your Morse Dealer to obtain a return authorization number, and for return freight advice. Return freight must be prepaid.

In all instances, liability is limited to the purchase price paid or to repairing or replacing the product. Customer assumes liability for any modifications, unauthorized repairs or parts substitution.

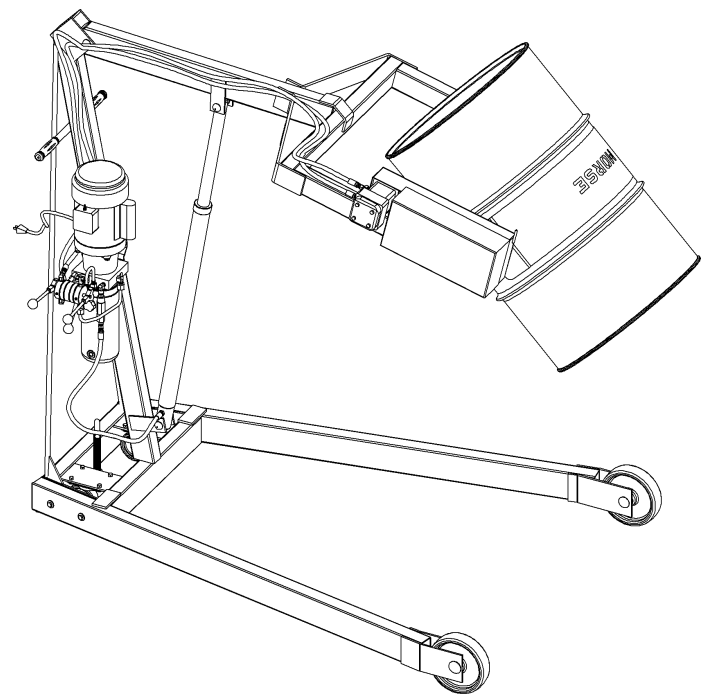

**Safety Information**

While Morse Manufacturing Co. drum handling equipment is engineered for safety and efficiency, a high degree of responsibility must be placed upon the machine operator to follow safe practices, based primarily on common sense, upon which true safety depends.

Failure to follow the safety precautions in this manual can result in personal injury or property damage. Observe the same precautions as with similar machinery where carelessness in operating or maintenance is hazardous to personnel. Carefully read the safety precautions below and throughout this manual.

**Operator's Manual for Morse Hydra-Lift Drum Karrier Model 400A-60-110**  
Serial Number 0103 to \_\_\_\_ (MMYY)

**Safety Information (continued)**



**DANGER** - Indicates a situation which, if not avoided, *will* result in serious injury or death. This signal word is limited to the most extreme situations.



**WARNING** - Indicates a situation which, if not avoided, *could* result in serious injury or death.



**CAUTION** - Indicates a situation which, if not avoided, can result in damage to the machine.



**CAUTION – Do Not Transport with Drum Raised**

*ALWAYS LOWER THE DRUM HOLDER TO LOWEST POSITION BEFORE TRANSPORTING.* The unit can become unstable when transporting with a raised load.



**DANGER - Stay Clear of Power Lines**

*KEEP WELL CLEAR OF POWER LINES.* Never approach a power line. Current in a high voltage line may arc some distance from the wire to the steel framed, grounded machine.



**WARNING**

The Hydra-Lift Karrier is designed to handle one drum of the types listed at the top of page 3, under **2. Machine Description**. *DO NOT* attempt to handle any other type of drum or object. *DO NOT* exceed the weight capacity of 800 Lb.



**WARNING - Level Floors Only**

For operation only on clean, level floors of suitable bearing capacity. Do not use on sloped surfaces, ramps, irregular or debris strewn floors.



**WARNING - Do Not Modify the Unit**

Under no circumstances should any modifications be made to the Morse machinery without factory authorization. Any modifications may void the warranty. This machine was designed to perform a specific job and alterations may result in injury to operator or machine.



**WARNING - No Loose Fitting Clothing**

Wear close-fitting clothing and safety equipment appropriate to the job. Loose fitting clothing may become caught on the machinery and cause severe personal injury.



**WARNING - Hydraulic Fluid Under Pressure Can Be Hazardous**

Escaping hydraulic fluid under pressure can penetrate the skin, causing serious injury. Avoid the hazard by relieving pressure before disconnecting hydraulic lines. Keep hands and body away from pinholes and nozzles, which eject fluid under high pressure. Use a piece of cardboard to search for leaks. If an accident occurs, see a doctor immediately and inform them of the nature of the accident.



**CAUTION - Wear Safety Shoes**

Wear safety shoes with non-slip soles and hard toe protection.

**Operator's Manual for Morse Hydra-Lift Drum Karrier Model 400A-60-110**  
Serial Number 0103 to \_\_\_\_ (MMYY)

**Machine Description**

The Model 400A-60-110 Hydra-Lift Karrier will pour a drum up to 60" high, measured from the floor to the lowest point of a horizontal drum. It is designed to lift, transport, and dispense a ribbed 55-gallon steel drum 22.5" in diameter.

- A smaller diameter drum can be handled with the correct size 55/30 Series Diameter Adaptor installed (see Diameter Adaptor literature)
- A 55-gallon plastic drum can be handled if the unit is equipped with an Adjustable Bracket (Option HDPS) or Top Rim Clamp (Option HDRC) (see plastic drum option manual).

The maximum full-drum capacity is 800 Lb. The capacity is derated to 500 Lb. for a half-full drum. The half-full rating is based on the tilt mechanism's capacity for handling an unbalanced bottom-heavy drum.

**Controls**

The Morse Hydra-Lift Karrier is manually propelled and steered. The drum lift and tilt controls are powered by a single phase 115V AC motor with a momentary switch, cord and plug.

There are two functions for the operator to control (Figure 2.1):  
1. "LIFT" and lower function for vertical positioning of the drum  
2. "TILT" function to control the degree of rotation of the drum

**1. LIFT and Lower Function**

To raise the drum

- a. Plug the motor into a standard 115V power supply.
- b. Turn the motor on by holding the momentary switch in the on position.
- c. With the motor on, raise the LIFT handle.

To lower the drum

- a. With the motor off, push in the LOWER handle.

**2. TILT Function**

To tilt the drum forward for pouring

- a. Turn on the motor by holding momentary switch in the on position.
- b. With the motor on, raise the tilt handle.

To return the drum to vertical position

- a. Turn on the motor by holding momentary switch in the on position.
- b. Push the tilt handle down.

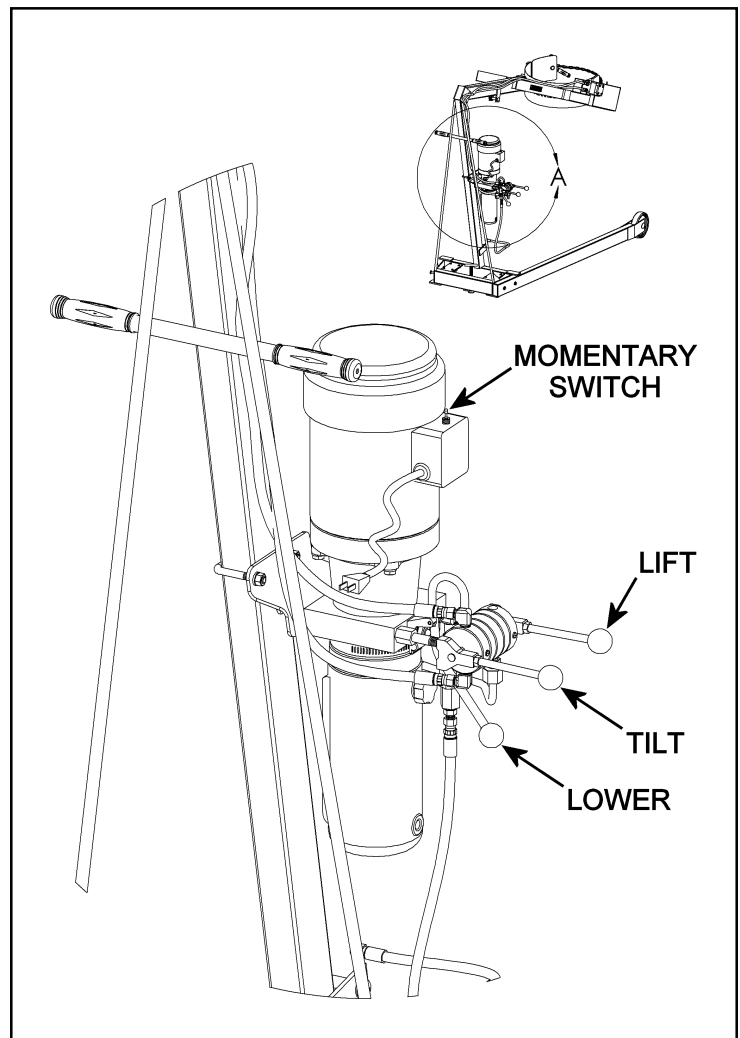

**Figure 2.1**

**Operator's Manual for Morse Hydra-Lift Drum Karrier Model 400A-60-110**  
 Serial Number 0103 to \_\_\_\_ (MMYY)

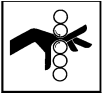

**WARNING - Watch Out for Pinch Points**

Stay clear of moving parts. Operator should remain behind the push handle during the lift operation.

**Floor Lock**

The screw-down floor lock is located on the base of the tower (figure 3.1). Turning the floor lock clockwise until it locks in the down position activates the floor lock. When the floor lock is activated it prevents unwanted free wheeling of the unit. Floor conditions determine the effectiveness of the floor lock. The operator should verify its holding action before depending on it to hold.

**Drum Holder Assembly**

The drum holder assembly (or "saddle assembly") is the component on the Hydra-Lift Karrier that is intended to hold the drum. The drum holder assembly is designed to secure a standard ribbed 55-gallon steel drum around it's middle using a cinch chain and ratchet tightening system. The drum holder accepts accessories for handling smaller diameter drums.

**Operating Instructions**

- 1.) Push the Hydra-Lift Karrier to the drum.
- 2.) Using the "LIFT" control as described in "**Machine Description - Controls**" (page 3) , position the drum holder assembly with the back band at the middle of the drum. (Figure 3.1). With the ratchet plate swung open and the cinch chain hanging from the chain hook, push the unit until the back band rests firmly against the drum. Some adjustment to the tilt angle of the saddle may be necessary to ensure band fits flush on the drum.
- 3.) **Attaching the drum:**  
 Drape the chain across the front of the drum and engage a link into the slot in the ratchet (Figure 3.2). Turn the ratchet clockwise to tighten chain. If ratchet turns until the pawl is beyond the last ratchet tooth, turn the ratchet back and slide the next link into the ratchet slot and try tightening again. The chain must be held tightly against the drum with the pawl engaged securely in the ratchet teeth.
- 4.) Operate the lift function to lift drum clear of floor. Roll to dispensing location. NOTE: Do not allow the drum to impact on floor, pouring station, etc. or a spill or damage could occur.

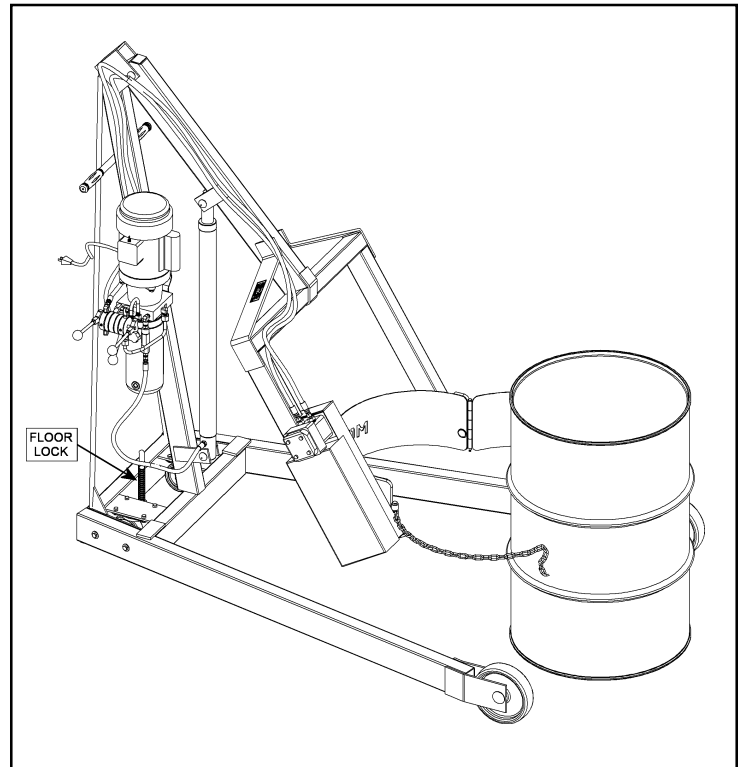

**Figure 3.1**

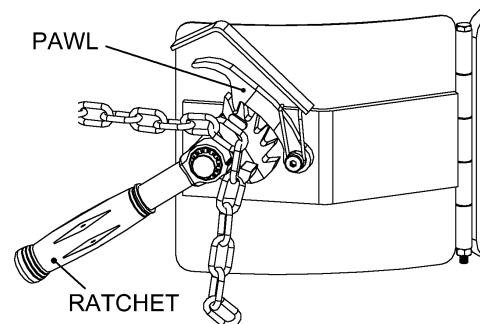

**Figure 3.2**

**Operator's Manual for Morse Hydra-Lift Drum Karrier Model 400A-60-110**  
Serial Number 0103 to \_\_\_\_ (MMYY)



**CAUTION – Do Not Transport with Drum Raised**

*ALWAYS LOWER THE DRUM HOLDER TO LOWEST POSITION BEFORE TRANSPORTING.* The unit can become unstable when transporting with a raised load.

- 5.) Lift drum to desired pouring height. Operate the tilt control as described in “**Machine Description - Controls**” (page 3) to adjust the drum attitude. This is especially important when lifting an open drum. The floor lock should be engaged while dispensing / draining.
- 6.) When dispensing is complete, tilt drum back to upright position. Disengage the floor lock and lower the drum to transporting height; about 6” off the floor.



**WARNING - Stay Clear of Raised Drum**

NEVER allow anyone to be below any part of a raised drum handler or drum. Remain behind the push handle while handling a drum.



**WARNING – Do NOT Disengage the Cinch Chain When Drum is off the Ground**

When the drum is in the upright position, lower the drum to the floor before releasing the cinch chain.

- 7.) Push the unit to the drum storage area and lower to the floor in an upright position. Release the cinch chain from the ratchet by applying pressure to the ratchet handle in a clockwise direction with one hand and opening the pawl to free the ratchet with the other hand. Remove the cinch chain link from the ratchet.

## Maintenance

Periodic inspection for the general condition of structural and mechanical components is imperative for safe and efficient operation.

Periodically inspect all moving parts, framework, and contact areas for signs of wear, fatigue, or loosening. Tighten, adjust, or replace parts as necessary to prevent failure and maintain proper function.

Inspect the hydraulic system for oil drips, hose damage, or other signs of wear. Inspect the level and condition of the hydraulic fluid. Replace any parts that show signs of wear.

Grease wheel bearings periodically. Oil or grease all moving parts including: the three clevis pins and the surfaces of the boom which contact the inside of the mast cap, the hinge pin, the gears and sprockets in the tilt drive, and the ratchet and pawl.

Worn or damaged parts must be properly replaced with the correct, genuine Morse parts.

Hydraulic pump is shipped filled with Noco Premium plus automatic transmission fluid d/m. Material safety data sheet (msds) is available online. Change oil yearly, sooner depending on dirty conditions or outdoor use. Replace oil with Mobil dte 24 or equivalent for indoor use (Mobil dte 13 for outdoor use).

**Operator's Manual for Morse Hydra-Lift Drum Karrier Model 400A-60-110**  
Serial Number 0103 to \_\_\_\_ (MMYY)

ITEM	QTY.	PART #	DESCRIPTION
1	1	793-72-P	OVERHEAD ASM, 72" PT
2	4	1521-P	HHCS, 3/8-16 X 3 GR5
3	4	1166-P	WASHER, 3/8 USS 1" OD
4	2	134-P	LEG WELD, 400A-72, 60
5	2	704-P	AXLE, 3/4", USE WITH PUSH-ON
6	2	705-P	CAP, HUB, PUSH-ON, 3/4"
7 *	2	87-P	WHEEL, MORTUF, 8", 3/4" BRG
8	3	64-P	ROLL PIN, 3/16 X 1-1/4
9	7	17-P	WASHER, 5/8 SAE FL 1-5/16 OD
10 *	2	3308-P	CASTER, 4" SWIVEL, DBL RACE
11	8	491-P	NUT, 5/16-18 REV HEX LOCK
12	3	138-P	CLEVIS PIN 5/8 X 3"
13	4	1169-P	NUT, 3/8-16 REV HEX LOCK
14	8	215-P	HHCS, 5/16-18 X 5/8 GR2
15	2	765-P	HYD FIT, MALE ELBOW, FLARE 400
16	1	781-P	CYLINDER, 1.5 X 22.625", SAE
17	2	136-P	GRIP, HANDLE 7/8" X 4-3/4"
18	1	135-P	ASM, TOWER, 400A-60, 72
19	1	3680-P	KIT, PUMP MOUNT PLATE, PL
20	1	1315-P	HHCS, 3/8-16 X 2-3/4 GR2
21	1	3641-P	U-BOLT, 3/8-16, 400 PUMP MOUNT
22	1	3643-P	MOUNT PLATE, POWER PUMP
23	7	1474-P	WASHER, 3/8 SPLIT LOCK
24	2	149-P	NUT, 3/8-16 FIN HEX
25	1	1657-P	HHCS, 3/8-16 X 3/4 GR2
26	1	1165-P	NUT, 3/8-16 JAM
27	1	3689-P	HYD HOSE ASM, 31"
28	1	345-P	HYD FIT, MALE FLARE, 456, 82
31	4	1572-P	HHCS, 3/8-16 X 1 GR2
32	1	M4507-P	HYD POWER PACK, -110, -114
33	1	1062-P	MOTOR 1HP 1PH TEFC 56C W/ CORD
34	1	3633-P	TOGGLE SWITCH, MOMENTARY, 400
35	2	1763-P	HYD HOSE ASM, 72 PT, 77"
* Recommended spare parts			

**Operator's Manual for Morse Hydra-Lift Drum Karrier Model 400A-60-110**  
 Serial Number 0103 to \_\_\_\_ (MMYY)

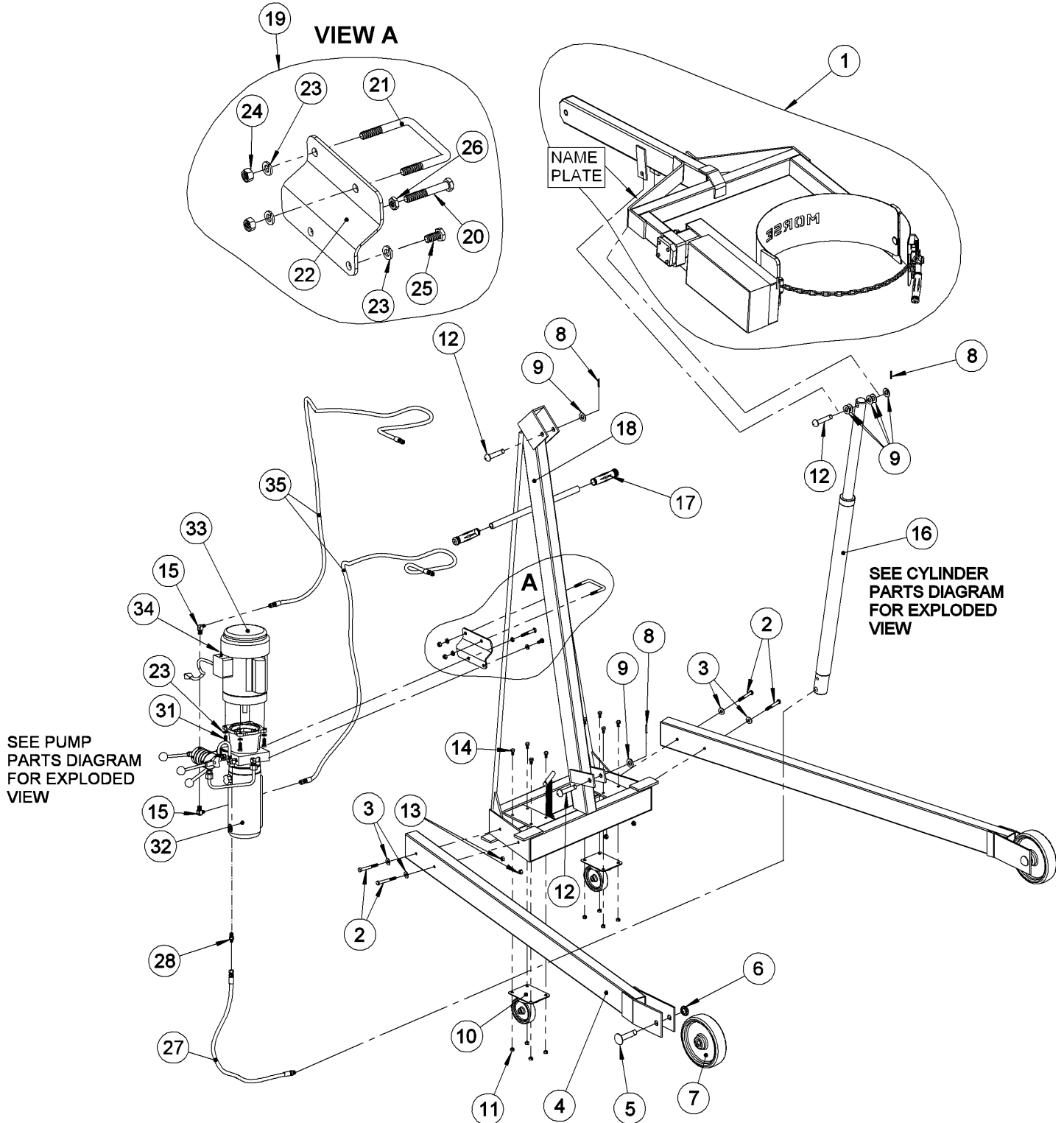

**Overhead Assembly (Part Number 793-72-P)**  
**for Morse Hydra-Lift Drum Karrier Model 400A-60-110**  
Serial Number 0103 to \_\_\_\_ (MMYY)

ITEM	QTY.	PART #	DESCRIPTION
50	1	745A-P	SADDLE ASM, A-HD, '88
51 *	1	726-P	A RATCHET HINGE PLATE CPT 1/4"
52 *	1	1296-P	HHCS, 1/4-20 X 7-1/2 GR5
53 *	1	1297-P	NUT, 1/4-20 REV HEX LOCK
54 *	1	180-P	CHAIN, CINCH, 3/16 ALLOY 33 LK
55 *	1	4081-P	NUT, M8 ESNA, 8MM
56 *	1	4079-P	HHCS, M8 X 60 MM GR5, 8MM
57 *	1	27-P	SPUR GEAR W/ 1" SHAFT, HD TYPE
59	1	29-P	SPACER, SPUR GEAR .15"
60	1	731-P	A RATCHET HINGE PLATE ONLY 1/4 (not sold separately)
61	1	165KIT-P	KIT, RATCHET CHAIN TIGHTENER
62	1	168-P	PAWL, WITH DRILLED HOLE
63	1	169-P	PAWL SPRING
64	1	170-P	SCREW, SHOULDER, 3/8 DIA X 5/8
65	1	710-P	RETAINER, RATCHET PUSH NUT 3/4
66	1	165-P	RATCHET, MALLEABLE, FOR SADDLE
67	1	136-P	GRIP, HANDLE 7/8" X 4-3/4"
68	1	792-72-P	OVERHEAD WELD, 72" PT
69	1	64-P	ROLL PIN, 3/16 X 1-1/4
70	2	55-P	WASHER, 3/4 SAE FL 1-1/2 OD
71 *	1	735-P	KEY, WOODRUFF, SIZE 9, ASA606
72 *	1	14-P	GEAR, PINION, 7 TOOTH
73 *	1	12-P	CHAIN, ROLLER, #35 W/ M LINK
74	1	795-P	LINK, MASTER, #35 CHAIN
75 *	1	13-P	SPROCKET #35 36T, 3/4" BORE
76 *	1	1116-P	SPROCKET #35 17T, 1" BORE
77	4	1657-P	HHCS, 3/8-16 X 3/4 GR2
78	4	1474-P	WASHER, 3/8 SPLIT LOCK
79 *	1	2656-P	KEY, SQUARE, 1/4 X 1"
80	2	2120-P	HYD FIT, MALE CONNECTOR, 400
81	1	351-P	MOTOR, HYDRAULIC HYD, 400, 456
82 *	1	7-P	BEARING, 3/4" ID X 1-1/2"
83 *	2	18-P	BEARING, 1" ID X 2-1/2"
84 *	2	736-P	KEY, WOODRUFF, SIZE 15, ASA808
85	1	15-P	COLLAR, 3/4" ID
86 *	1	30-P	SPROCKET #40D 16T, 1" BORE
87 *	1	31-P	CHAIN, ROLLER, #40D W/ M. LINK
88	1	796-P	LINK, MASTER, #40D CHAIN
89 *	1	32-P	SPROCKET #40D 32T, 1" BORE
90	1	1049-P	KIT, SQ COVER, 400 PT
91	1	1772-P	COVER HALF SQ, 1 HOLE, 400 PT
92	1	1755-P	COVER HALF SQ, NO HOLES 400 PT
93 *	9	193-P	SCREW, TEK, 12-14 X 3/4, 3 PT
* Recommended spare parts.			

**Overhead Assembly (Part Number 793-72-P)**  
for Morse Hydra-Lift Drum Carrier Model 400A-60-110  
Serial Number 0103 to \_\_\_\_ (MMYY)

