

**Operator's Manual for Morse Bracket Assembly Kit - Part # 4556-P**  
**Serial Number 0209 to \_\_\_\_ (MMYY)**

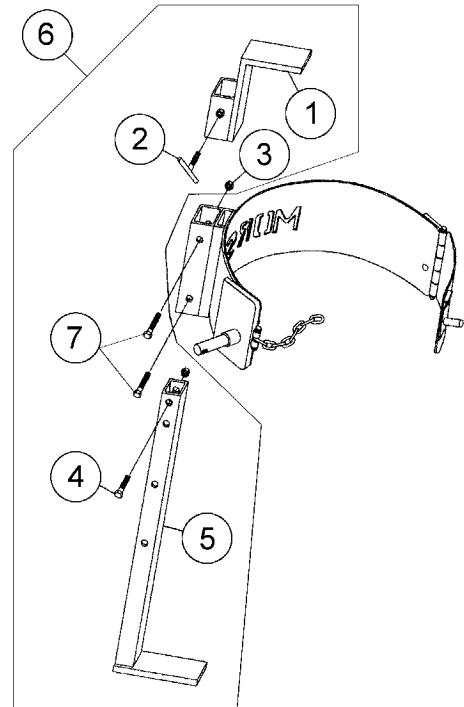
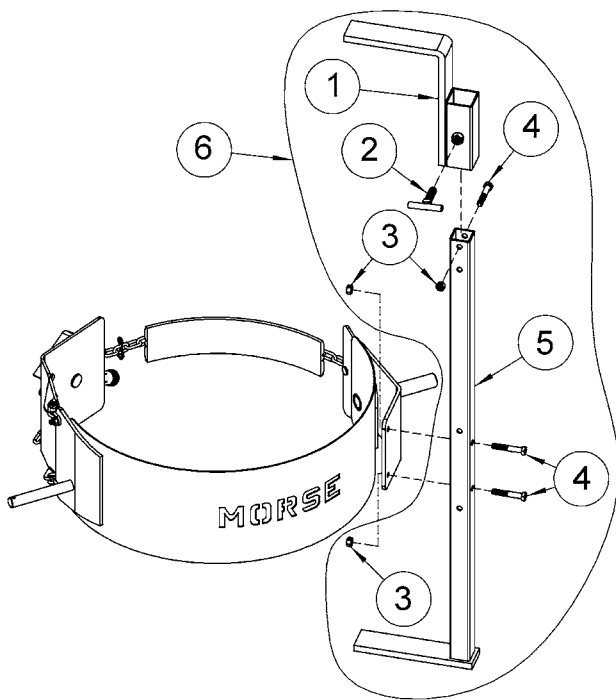

**INSTALLATION INSTRUCTIONS**  
**for MORcinch Drum Holder**

1. Bolt bottom bracket (item 5) to drum holder, using 2 bolts (item 4) and 2 nuts (item 3), bolt in place through the 2 lowest holes on bottom bracket.
2. Slide hold down (item 1) down over top of bottom bracket and tighten in place with tee handle (item 2).
3. Fasten stop bolt (item 4) and nut (item 3) into top hole of bottom bracket.

**INSTALLATION INSTRUCTIONS**  
**for Drum Holder with Socket Tube**

1. Slide bottom bracket (item 5) up through socket tube and, using 2 bolts (item 7) and 2 nuts (item 3), bolt in place through the 2 lowest holes on bottom bracket.
2. Slide hold down (item 1) down over top of bottom bracket and tighten in place with tee handle (item 2).
3. Fasten stop bolt (item 4) and nut (item 3) into top hole of bottom bracket. Use bottom hole for 195 Series starting with serial number 0207.

| ITEM | QTY. | PART # | DESCRIPTION                     |
|------|------|--------|---------------------------------|
| 1    | 1    | 1371-P | HOLD DOWN, BRACKET ASM          |
| 2    | 1    | 1372-P | TEE HANDLE, BRACKET ASM, 1-1/2  |
| 3    | 3    | 1169-P | NUT, 3/8-16 REV HEX LOCK        |
| 4    | 3    | 82-P   | HHCS, 3/8-16 X 2-1/4 GR2        |
| 5    | 1    | 4561-P | WELD, BRACKET, 4 HOLE, MORcinch |
| 6    | 1    | 4556-P | KIT, BRACKET ASM, MORcinch      |
| 7    | 2    | 1315-P | HHCS, 3/8-16 X 2-3/4 GR2        |

**Operator's Manual for Morse Bracket Assembly Kit - Part # 4556-P**  
**Serial Number 0209 to \_\_\_\_ (MMYY)**

**OPERATING INSTRUCTIONS**

**TO SECURE DRUM:**

1. Position drum holder assembly so bottom bracket (item 5) rests on floor.
2. Loosen tee handle (item 2) and slide hold down (item 1) up to highest position. Tighten tee handle.
3. Load drum onto bottom bracket and into drum holder with a hand truck.
4. Loosen tee handle and slide hold down to meet top of drum. Tighten tee handle. (see Figure 1)
5. Secure drum with chain and ratchet mechanism. Drum is now ready to be lifted and tilted.

**TO RELEASE DRUM:**

1. Lower drum to floor in upright position.
2. Release chain from ratchet mechanism by applying pressure to ratchet handle in a clockwise direction with one hand and opening pawl to free ratchet with other hand. Remove chain link from ratchet.
3. Loosen tee handle and slide hold down up to highest position. Tighten tee handle.
4. Remove drum with hand truck.

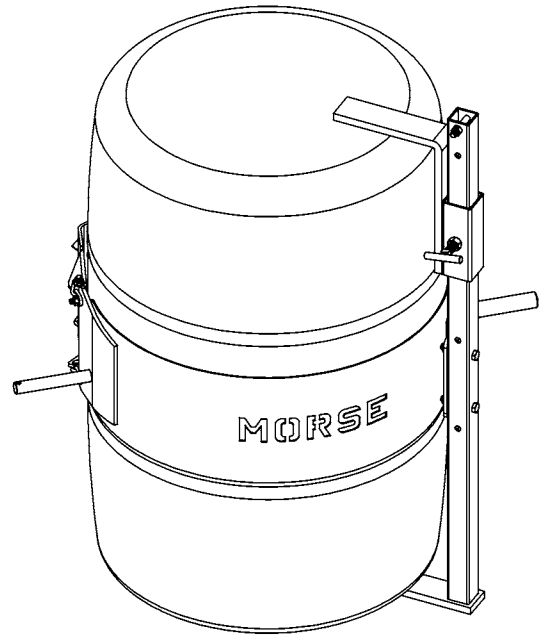

**Figure 1**

Plastic drum being lifted with part number 4556-P Bracket Assembly Kit installed.