

Contents

	Page
Receiving Procedures.	1
Warranty.	1
Safety Information.	1 - 2
Machine Description.	3
Operating Instructions.	3
Maintenance.	3
Parts List and Diagram.	4

Operator's Manual
for Morse 5-Gallon Pail-Karrier

Model 85-5
Serial number 0310 to ____ (MMYY)

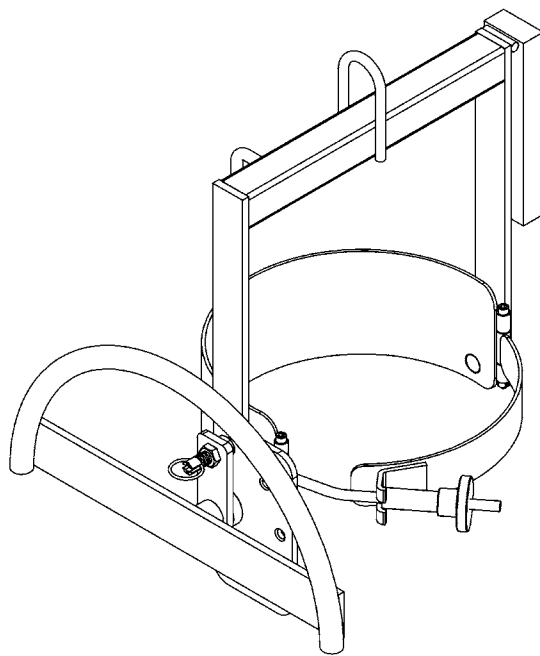

Receiving Procedures

Every Morse pail handler is inspected prior to shipping. However, damage may be incurred during transit.

- Check for visible damage. If you choose to accept damaged freight, always sign noting the damage on the **Bill of Lading**.
- Document the damage and have the truck driver sign. We recommend keeping a digital camera at your receiving dock for this purpose.
- Open packages expeditiously to check the condition of the goods. There is only a 24 hour window to notify the carrier of any concealed damage.
- Immediately **report all damage to the shipping company!** Then you may contact Morse for assistance with your freight claim.
- Morse Manufacturing will not be held responsible for any damaged freight that is not signed for as damaged.

Limited 2 Year Warranty

Morse pail handling equipment is guaranteed against defects in workmanship or materials for two years when used properly within its rated capacity. Warranty does not cover wear from normal use or damage from accident or abuse. Motors and other purchased parts carry the warranties of their manufacturers.

For warranty claims, contact your Morse Dealer to obtain a return authorization number, and for return freight advice. Return freight must be prepaid.

In all instances, liability is limited to the purchase price paid or to repairing or replacing the product. Customer assumes liability for any modifications, unauthorized repairs or parts substitution.

Safety Information

While Morse Manufacturing Co. pail handling equipment is engineered for safety and efficiency, a high degree of responsibility must be placed upon the machine operator to follow safe practices, based primarily on common sense, upon which true safety depends.

Failure to follow the safety precautions in this manual can result in personal injury or property damage. Observe the same precautions as with similar machinery where carelessness in operating or maintenance is hazardous to personnel. Carefully read the safety precautions below and throughout this manual.

Review the Material Safety Data Sheet(s) for the material(s) in the pail(s) and take all necessary precautions. Safety shoes, work gloves, hard hat and other personal protective devices are recommended.

Prior to initial use, inspect all moving parts. Perform necessary load test, inspections, operator training, etc.

Operator's Manual for Morse Model 85-5 Pail Karrier Serial number 0310 to ____ (MMYY)

Safety Information (continued)



DANGER - Indicates a situation which, if not avoided, will result in serious injury or death. This signal word is limited to the most extreme situations.



WARNING - Indicates a situation which, if not avoided, could result in serious injury or death.



CAUTION - Indicates a situation which, if not avoided, can result in damage to the machine.



WARNING - Pail-Karrier is designed to handle one pail of the types listed at the top of page 3. Machine Description. DO NOT attempt to handle any other type of pail or object.



WARNING - DO NOT exceed the weight capacity of 200 Lb.



WARNING - DO NOT operate damaged or malfunctioning unit, or a unit with missing parts.



WARNING - DO NOT lift people or suspend loads over people. Stay clear of suspended loads.



WARNING - DO NOT lift loads higher than necessary.



WARNING - DO NOT leave suspended loads unattended.



WARNING - DO NOT remove or obscure warning labels.



WARNING - DO NOT operate without first having read and understood operating manual.



WARNING - DO NOT make alterations or modify the unit. Under no circumstances should any modifications be made to the Morse machinery without factory authorization. Any modifications may void the warranty. This machine was designed to perform a specific job and alterations may result in injury to operator or machine.



WARNING - Wear safety shoes with non-slip soles and hard toe protection.



CAUTION: DO NOT allow pail to impact on floor, ground, etc.

Operator's Manual for Morse Model 85-5 Pail Karrier
Serial number 0310 to ____ (MMYY)

Machine Description

Model 85-5 Pail-Karrier is designed to lift, transport and dispense a standard 5-gallon steel or plastic, pail 11" to 12" in diameter. The maximum capacity is 200 Lb.



Important

1. Review the Material Safety Data Sheet(s) for the material(s) in the pail(s) and take all necessary precautions. Safety shoes, work gloves, hard hat and other personal protective devices are recommended.
2. Please read all instructions thoroughly before attempting to operate your new Morse pail handler.
3. The 85-5 Pail-Karrier has a maximum capacity rating of 200 Lb. for a FULL pail and 100 Lb. for a HALF-FULL pail, and is designed to lift and move a pail of the size and type noted above. DO NOT exceed this rating. Exceeding this rating or handling pails other than those mentioned above is unsafe and could result in equipment damage, excessive wear, awkward or dangerous handling.
4. When loading, unloading, operating, or maintaining your MORSE pail handler, always use care and good judgment. Maintain secure footing and a firm hold. Keep hands and loose clothing away from all moving parts. Never allow anyone to be below any part of a raised pail handler or pail. Read operating instructions and review the pictures in the sales brochure before operation.
5. The 85 Series are a "Group 1 structural and mechanical" below-the-hook lifting device which are covered by the American National Standard ASME B30.20. The user should comply with all aspects of this standard.

Assembly Instructions

1. Place the hand wheel onto the shaft of the drum holder.
2. Insert roll pin into underside of hand wheel collar and gently hammer through hole in shaft of drum holder to secure hand wheel on the shaft.

Operating Instructions

1. Start with Pail-Karrier on the floor. Lower hoist and engage hoist hook to lift Pail-Karrier.
2. Lock the pail holder in horizontal position for an upright pail using the spring loaded plunger tilt-lock.
3. Raise hoist to lift Pail-Karrier clear of floor and transport it to the pail.
4. Suspend the Pail-Karrier at a height which aligns the saddle (pail holder) with center of pail.
5. If the pail has a pivoting wire handle, swing it to lay on the front side to clear the back band of the saddle. Swing the front hinge band and clamp screw knob to the open position. Push the Pail-Karrier forward until the back band rests firmly against the pail.
6. Secure the pail: Swing the pail's pivoting wire handle to lay on the back band side of the saddle. Close the front hinge band tightly against the pail. Swing the clamp screw knob to engage the threaded rod into the notch on the front hinge band. Tighten the clamp screw knob to secure the pail into the saddle.
7. Raise hoist and position pail at pouring station.
8. Before unlocking the tilt-lock to permit tilting the pail, it is recommended that you steady the pail and be prepared for its possible tendency to tilt toward its heavier side.
9. With tilt-lock unlocked, use the hand wheel to tilt the pail for pouring. The pail pouring angle may be varied or it can be locked in various positions with the tilt-lock.
10. After emptying, rotate pail back to vertical position and lower hoist to return the empty pail.

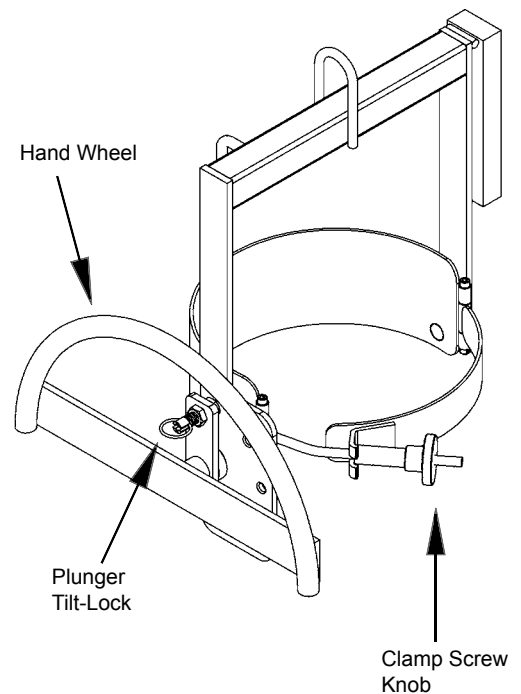

Maintenance

1. Lubricate tilt lock, fulcrum shafts and other moving parts periodically to maintain free action and reduce wear.
2. Periodically inspect all moving parts, framework and contact areas for signs of wear, fatigue or loosening. Tighten, adjust or replace parts as necessary to prevent failure and maintain proper function.

Operator's Manual for Morse Model 85-5 Pail Karrier
Serial number 0310 to ____ (MMYY)

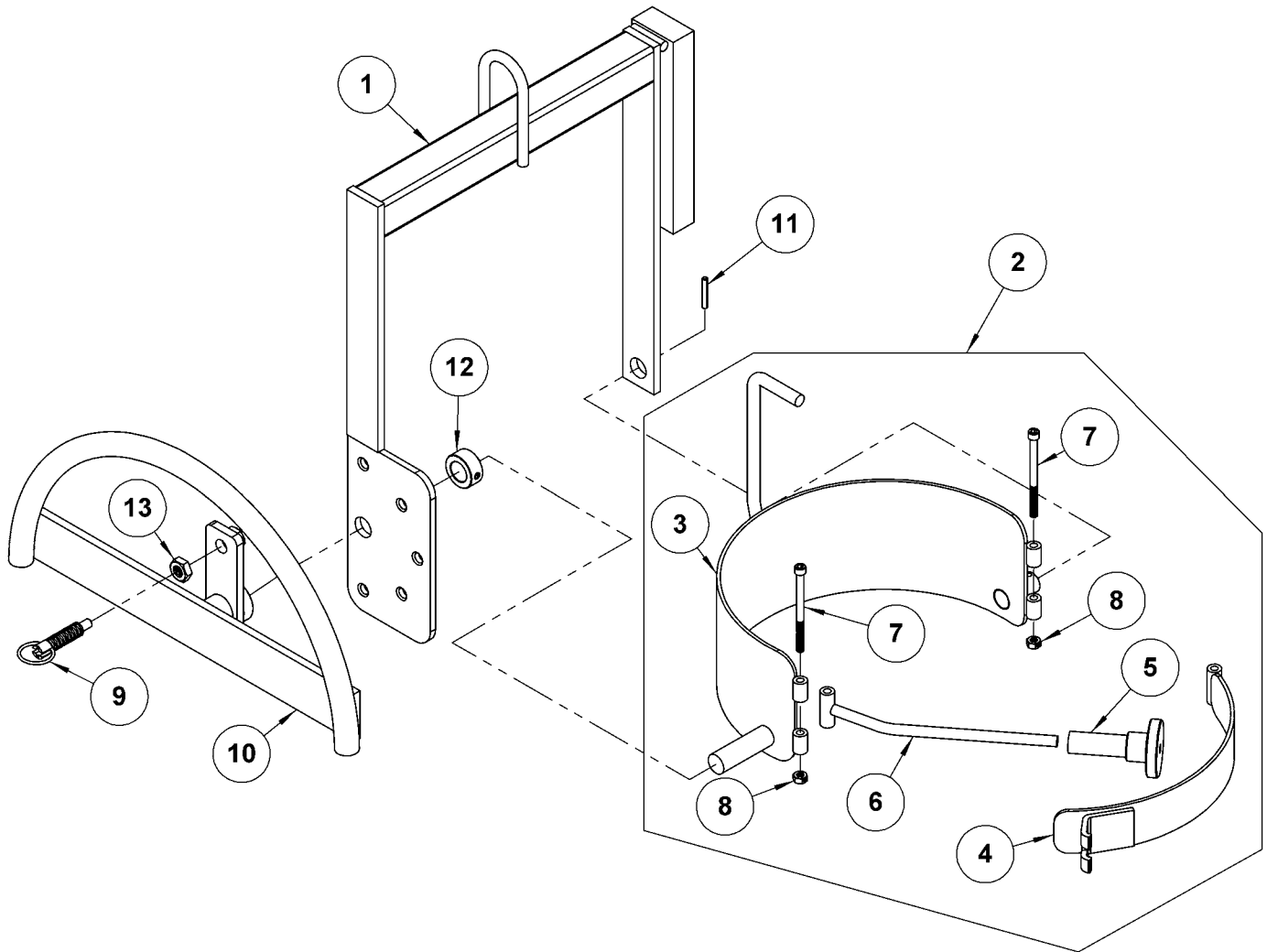

ITEM	QTY.	PART #	DESCRIPTION
1	1	4857-P	OVERHEAD WELD, 85-5
2	1	4864-P	SADDLE ASM, 85-5
3	1	4865-P	WELD, BACK BAND, 85-5
4	1	3795-P	WELD, FRONT BAND, 83
5	1	3714W-P	KNOB WELD, CLAMP SCREW 83, 7-X
6	1	4221-P	CLAMP SCREW WELD, 83
7	2	3804-P	SHCS, 1/4-20 X 3-1/4
8	2	1297-P	NUT, 1/4-20 REV HEX LOCK
9	1	4697-P	PLUNGER, 1/2-13, PULL RING
10	1	4866-P	HANDWHEEL WELD, 85-5
11	1	64-P	ROLL PIN, 3/16 X 1-1/4
12	1	15-P	COLLAR, 3/4" ID
13	1	4687-P	NUT, 1/2-13 JAM