

Operator's Manual for Morse Model 90-85 Verti-Karrier for 85-Gallon Drum

For replacement parts, please contact your Morse dealer.

When ordering parts, please specify:

- Part number and description
- Model number
- Serial number

Find model number and serial number on metal name plate attached to frame.

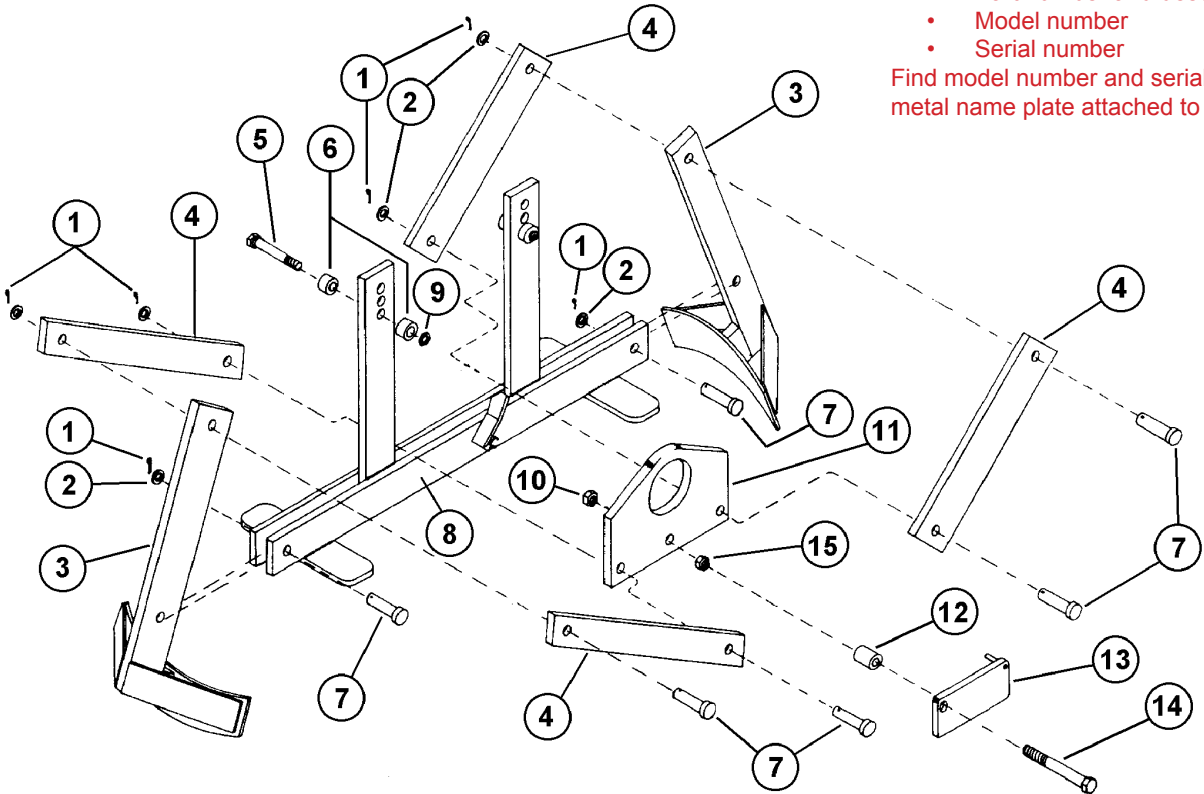

ITEM	QTY.	PART #	DESCRIPTION
1*	6	785-P	COTTER PIN, 1/8" X 1"
2	6	173-P	WASHER, 1/2 SAE FL 1-1/16 OD
3	2	1403-P	ARM WELD, 90-85
4	4	985-P	LINK, 90, 6/88
5	2	1168-P	HHCS, 1/2-13 X 2 GR2
6	4	151-P	STOP SPACER, 90
7*	6	1167-P	CLEVIS PIN, 1/2" X 1-3/8", 90
8	1	1407-P	BASE WELD, 90-85
9	2	91-P	NUT, 1/2-13 FIN HEX
10	1	1169-P	NUT, 3/8-16 REV HEX LOCK
11	1	980-P	LIFTING PLATE, B/O, DRILLED 90
12	1	1968-P	TUBING, 5/8 OD X .688 90 155 7
13	1	145-P	LATCH WEIGHT WELD, 90
14	1	82-P	HHCS, 3/8-16 X 2-1/4 GR2
15	1	1165-P	NUT, 3/8-16 JAM

* Recommended spare parts.