

Operator's Manual for Morse Model 90-SS Stainless Steel Verti-Karrier

For replacement parts, please contact your Morse dealer.

When ordering parts, please specify:

- Part number and description
- Model number
- Serial number

Find model number and serial number on metal name plate attached to frame.

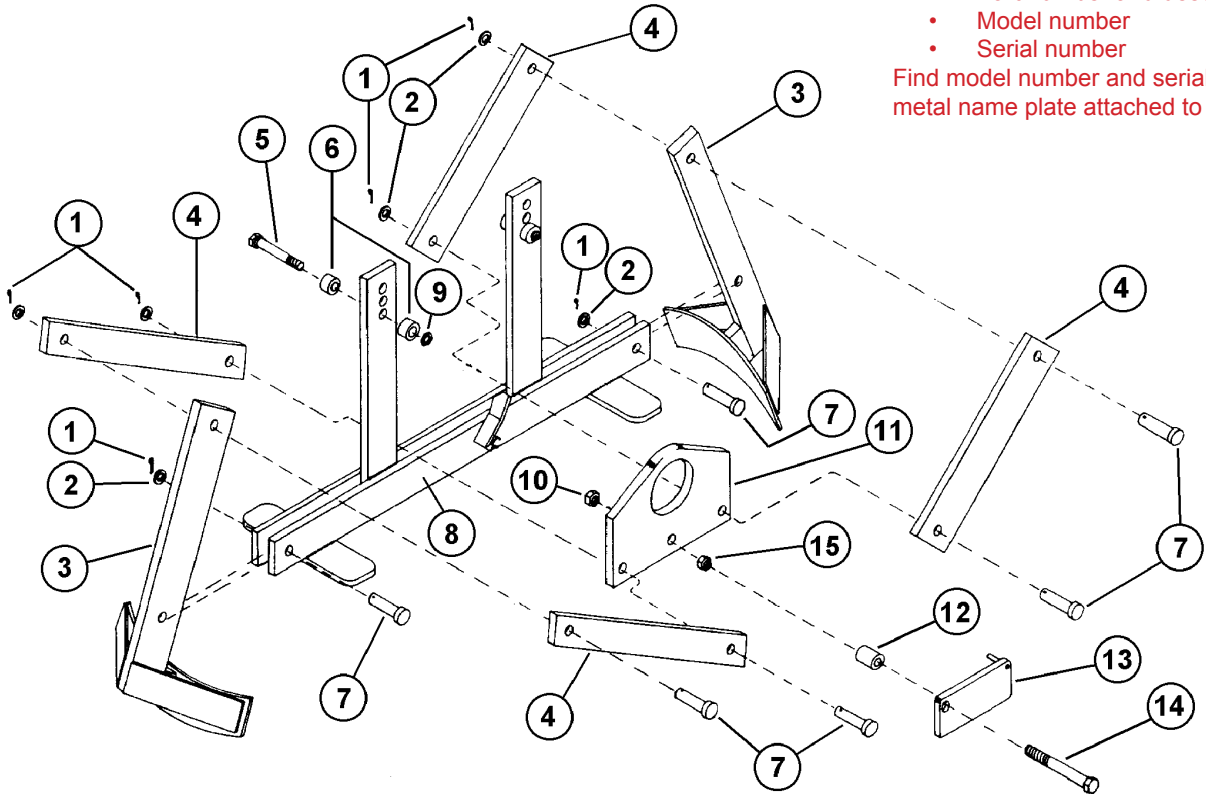

ITEM	QTY.	PART #	DESCRIPTION
1*	6	785SS-P	COTTER PIN, 1/8" X 1", SS
2	6	173SS-P	WASHER, 1/2 SAE 1-1/16 OD SS
3	2	143SS-P	ARM WELD, 90-SS
4	4	985SS-P	LINK, 90-SS
5	2	3358SS-P	HHCS, 1/2-13 X 2-1/4, SS
6	4	151SS-P	STOP SPACER, 90-SS
7*	6	1167SS-P	CLEVIS PIN, 90-SS
8	1	144SS-P	BASE WELD, 90-SS
9	2	810SS-P	NUT, 1/2-13 NYLON LOCK, SS
10	1	3981SS-P	NUT, 3/8-16 NYLON LOCK, SS
11	1	980SS-P	LIFTING PLATE, 90-SS
12	1	1968SS-P	LATCH SPACER, 90-SS
13	1	145SS-P	LATCH WEIGHT WELD, 90-SS
14	1	4492SS-P	HHCS, 3/8-16 X 2, SS
15	1	1165SS-P	NUT, 3/8-16 JAM SS

* Recommended spare parts.