

Operator's Manual for Morse Model 92-5 with Serial Number 0000 to ____ (MMYY)

Drum Lifter for 11" to 15" Diameter Rimmed Drum

For replacement parts, please contact your Morse dealer.

When ordering parts, please specify:

- Part number and description
- Model number
- Serial number

Find model number and serial number on metal name plate attached to frame.

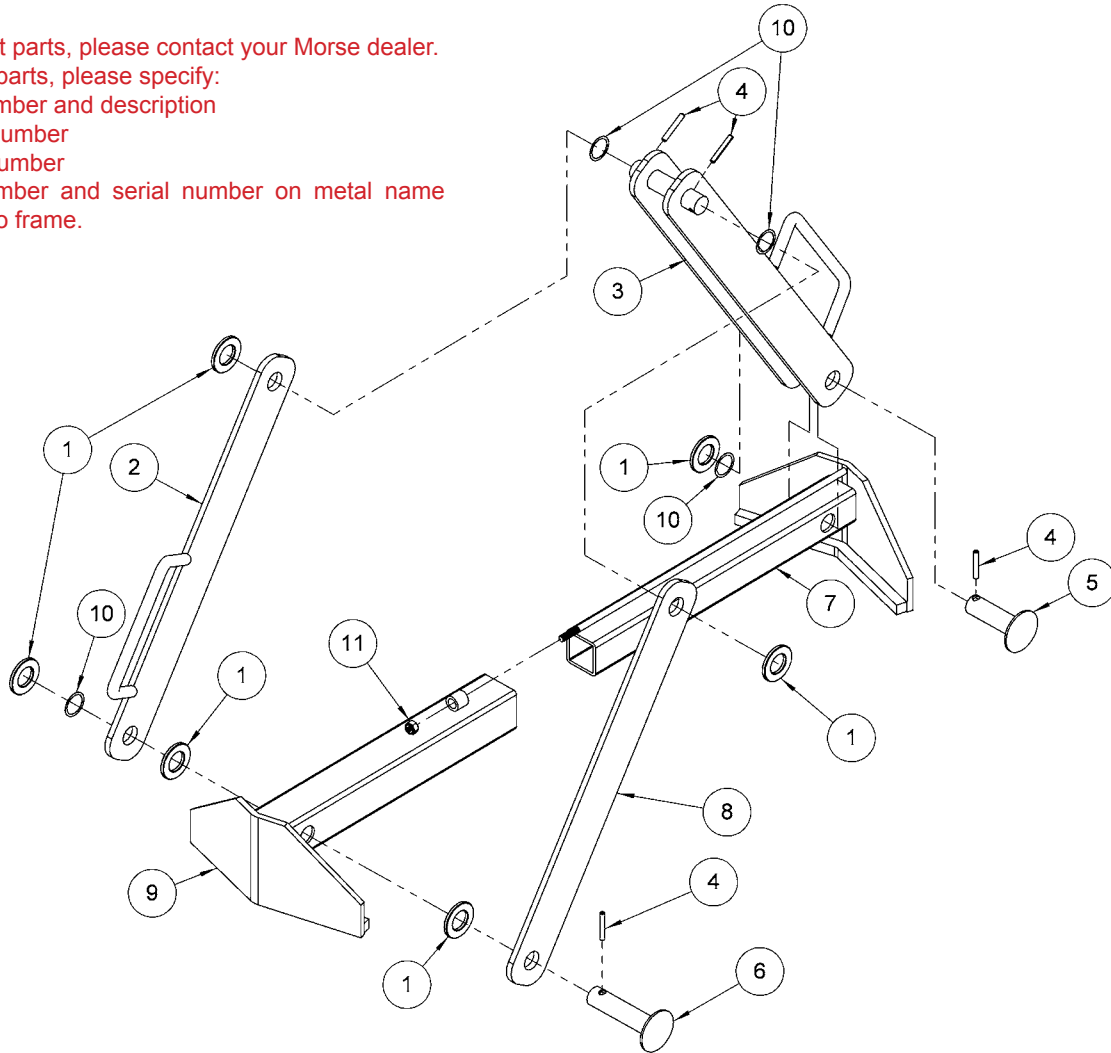

ITEM	QTY.	PART #	DESCRIPTION
1	6	55-P	WASHER, 3/4 SAE FL 1-1/2 OD
2	1	4425-P	LINK WELD W/ HANDLE, 92-5
3	1	4426-P	DOUBLE LINK WELD, 92-5
4	4	64-P	ROLL PIN, 3/16 X 1-1/4
5	1	1435-P	CLEVIS PIN, SMALL TUBE, 92
6	1	1436-P	CLEVIS PIN, LARGE TUBE, 92
7	1	4421-P	SMALL SLIDER TUBE WELD, 92-5
8	1	4424-P	LINK, 92-5
9	1	4420-P	LARGE SLIDER TUBE WELD, 92-5
10	4	4319-P	WAVE DISC SPRING, 3/4" .0105"
11	1	4250-P	NUT, 1/4-28 NYLON LOCK