

**Operator's Manual for Morse Model 92-SS**  
**Stainless Steel Drum Lifter for 18" to 26" Diameter Rimmed Drum**  
**with Serial Number 0414 to 0915**

For replacement parts, please contact your Morse dealer.

When ordering parts, please specify:

- Part number and description
- Model number
- Serial number

Find model number and serial number on metal name plate attached to frame.

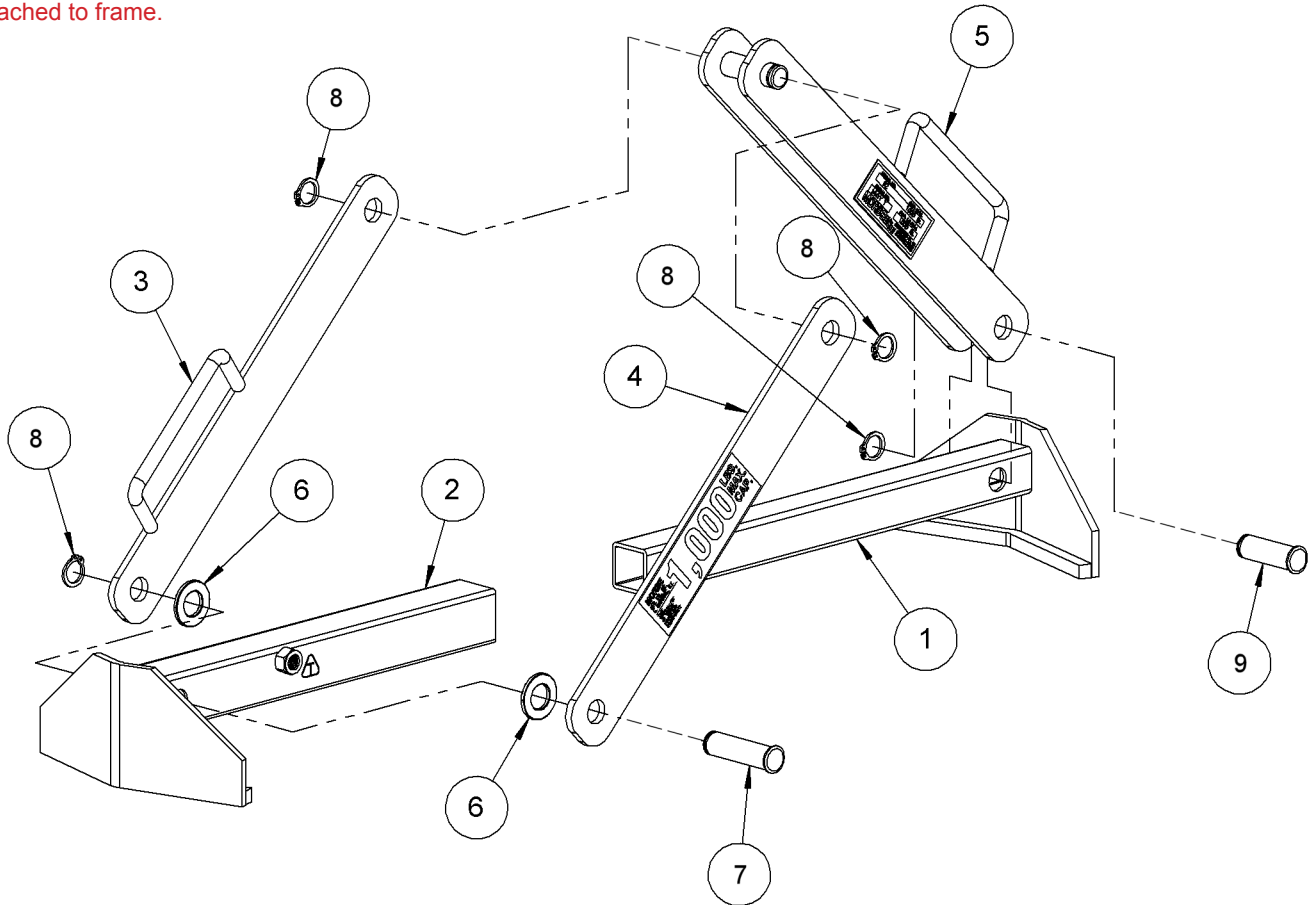

ITEM	QTY.	PART #	DESCRIPTION
1	1	1439SS-P	SMALL SLIDER TUBE WELD, 92-SS
2	1	1438SS-P	LARGE SLIDER TUBE WELD, 92-SS
3	1	1440SS-P	LINK WELD W/ HANDLE, 92-SS
4	1	1429SS-P	LINK, 92-SS
5	1	5588SS-P	DOUBLE LINK WELD, 92-SS
6	2	55SS-P	WASHER, 3/4 SAE FL 1-1/2 OD SS
7	1	5585SS-P	CLEVIS PIN, GROOVE, 3/4, SS
8	4	5330SS-P	SNAP RING, EXT, SS, 3/4"
9	1	5586SS-P	CLEVIS PIN, GROOVE, 3/4, SS