

**Operator's Manual for Morse Model 92M
 Spark Resistant Drum Lifter for 18" to 26" Diameter Rimmed Drum
 with Serial Number 1015 to _____**

For replacement parts, please contact your Morse dealer.

When ordering parts, please specify:

- Part number and description
- Model number
- Serial number

Find model number and serial number on metal name plate attached to frame.

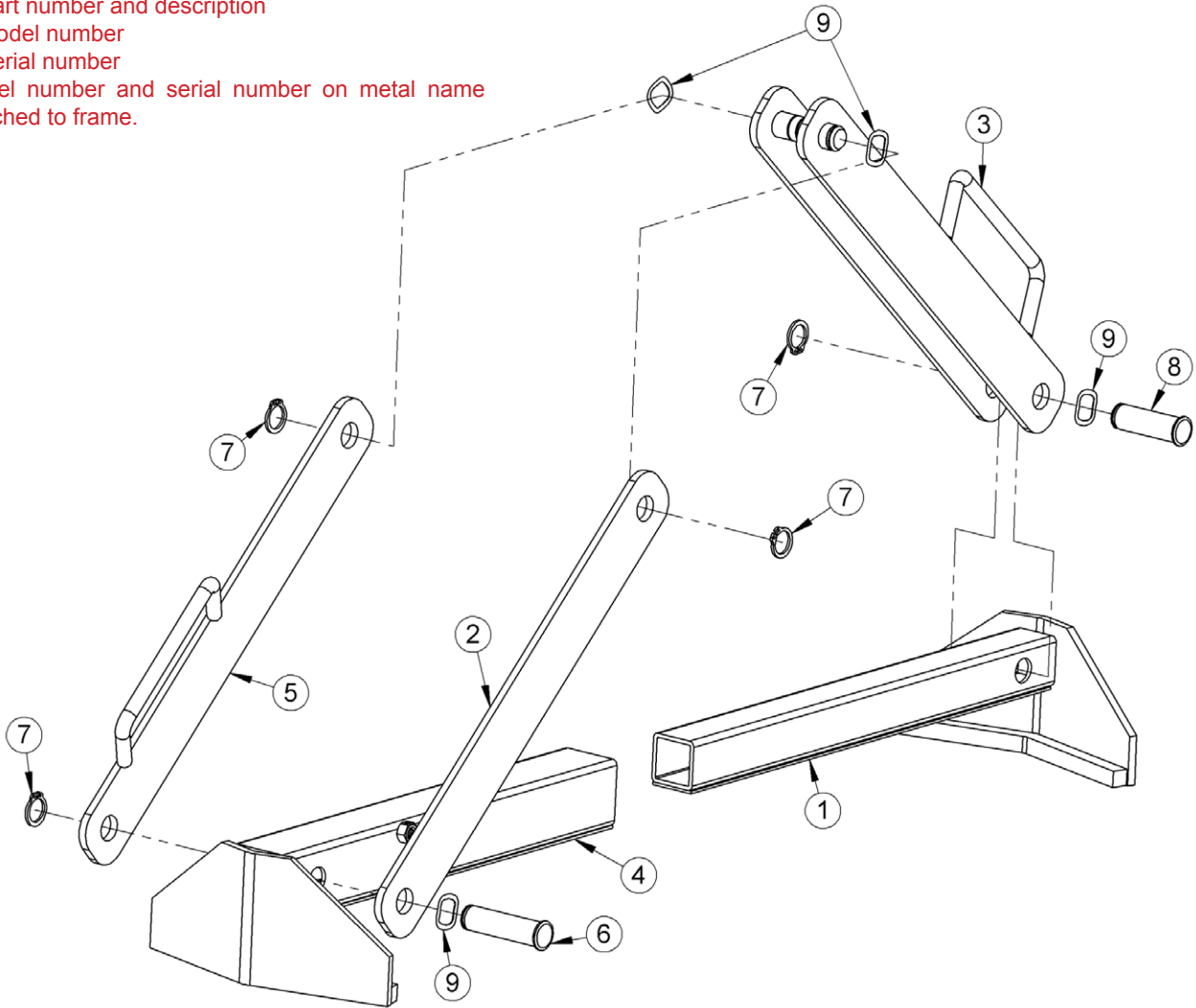

ITEM NO.	PART NUMBER	DESCRIPTION	QTY.
1	1439M-P	SMALL TUBE WELD, 92M SR	1
2	1429M-P	SR LINK, 92M	1
3	5588M-P	DOUBLE LINK WELD, 92	1
4	1438M-P	LARGE TUBE WELD, 92M SR	1
5	1440M-P	SR LINK WELD W HANDLE 92M	1
6	5585-P	PIN, GROOVE, 3/4 X 2.61	1
7	5330-P	SNAP RING, EXT, HD, .078, 3/4"	4
8	5586L-P	PIN, GROOVE, 3/4 X 2.18 C	1
9	4319-P	WAVE DISC SPRING, 3/4" .0105"	4