

**Operator's Manual for Morse Model 92M**  
**Spark Resistant Drum Lifter for 18" to 26" Diameter Rimmed Drum**

For replacement parts, please contact your Morse dealer.

When ordering parts, please specify:

- Part number and description
- Model number
- Serial number

Find model number and serial number on metal name plate attached to frame.

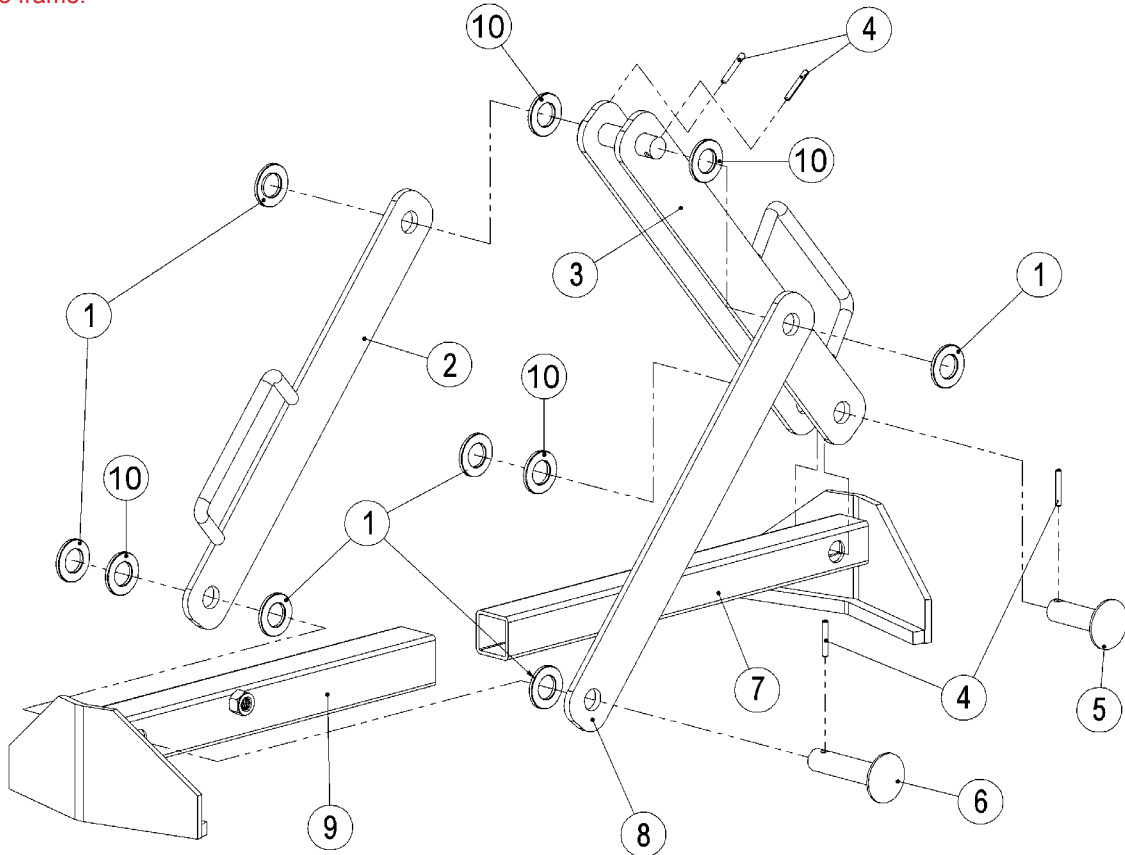

ITEM	QTY.	PART #	DESCRIPTION
1	6	55SS-P	WASHER, 3/4 SAE FL 1-1/2 OD SS
2	1	1440M-P	SR LINK WELD W HANDLE 92-M
3	1	2502-P	SR 2 LINK WELD, 92-M
4	4	64-P	ROLL PIN, 3/16 X 1-1/4
5	1	2504-P	SR PIN, SMALL TUBE CLEVIS 92-M
6	1	2505-P	SR PIN, LIFTING EYE, 92-M
7	1	1439M-P	SMALL TUBE WELD, 92-M SR
8	1	1429M-P	SR LINK, 92-M
9	1	1438M-P	LARGE TUBE WELD, 92-M SR
10	4	4319-P	WAVE DISC SPRING, 3/4" .0105"