

Operator's Manual
for Star Hydraulic Pump
Model 96MK1939-P
Serial Number 0604 to ____ (MMYY)

Contents

	Page
Parts Lists and Diagrams.	1
Service Instructions.	2 - 4

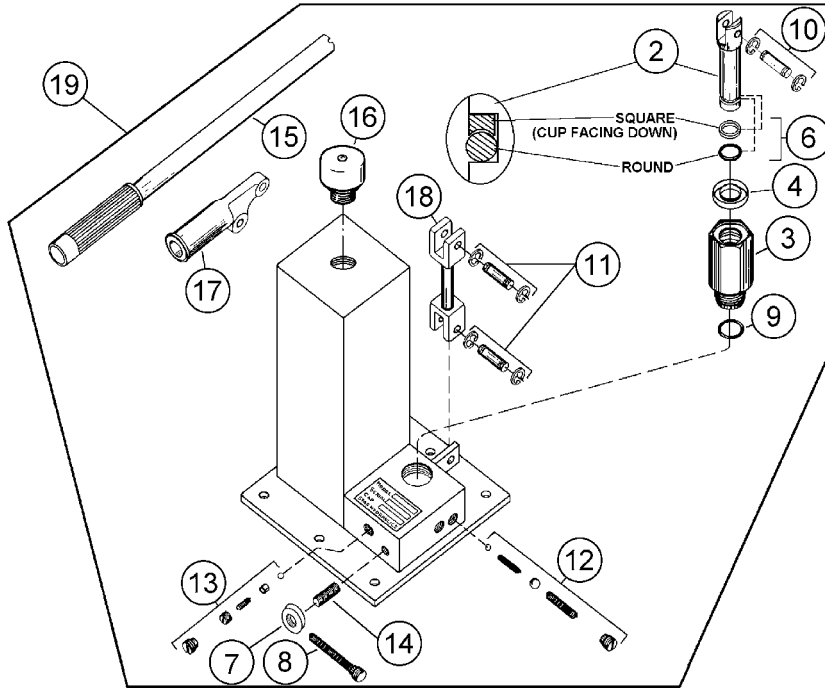

ITEM #	QTY.	PART #	DESCRIPTION
1	1	96MK1939-20	REPAIR KIT (Includes Items Marked *)
2	1	96MK1728-4	PUMP PISTON
3	1	96MK1728-2	PUMP BARREL
4 *	1	96MK1728-7	PUMP PISTON WIPER
6 *	1	96MK1728-5&6	PUMP PACKING AND BACK UP
7	1	1035-P	COLLAR, 1/2", RELEASE VALVE
8	1	1040-P	1/4 - 20 X 2-1/2 SHCS STL
9 *	1	96P1-20	PUMP BARREL "O" RING
10	1	96CP13-10RP	PISTON PIN (INCLUDES RINGS)
11	2	96CP13-10RP	LINK PIN (INCLUDES RINGS)
12 *	1	96P1-12RP	PUMP VALVE (COMPLETE)
13	1	96CP13-13RP	OVERLOAD VALVE (COMPLETE)
14	1	96MK1939-3RP	RELEASE VALVE (COMPLETE)
15	1	96CP13-23	LEVER HANDLE
16	1	96P1-16	BREATHER SCREW
17	1	96CP13-9	PUMP SOCKET
18	1	96CP13-12	PUMP LINK
19	1	96MK1939-P	PUMP, HYD, HAND, STAR

* Included in item # 1, Repair Kit, 96MK1939-20

Operator's Manual for Star Single Piston Hydraulic Pump

As installed on: 400 Series Serial # 0604 to ____ (MMYY)
405 Series Serial # 0604 to ____ (MMYY)
82 Series Serial # 0604 to ____ (MMYY)

MAINTENANCE

In servicing hydraulic units, cleanliness is of the utmost importance. A clean work place and proper tools are necessary to insure efficient and effective repair. Special tools can be furnished on request.

AIR BLEEDING

Air accumulation in a hydraulic system will cause erratic action. This may appear as pump failure to the inexperienced user. For this reason, it is advisable to air bleed each pump before attempting to operate. To remove air from the pump, open release valve with pump in an upright position. Operate the pump slowly through the full piston stroke about a dozen times. Close the release valve. Pump should be ready for use.

OIL

If the pump fails to operate, check the oil level before attempting any repairs. The maximum fill level is 1.5" below the inside of the reservoir cover. The reservoir has an 80 cubic inch capacity. CAUTION: Use only Hydraulic Oil when refilling. NEVER USE BRAKE FLUID. Approved Sources: Mobile DTE 11M - Product # 603100-0, Lubriplate "Special low pour hydraulic oil" # 76762 (pour -750F). Emergency Sources: SAE 5W Motor Oil - (Viscosity 60 S.U.S.), Automatic transmission fluid.

NOTE: Specify pump model number when ordering parts.

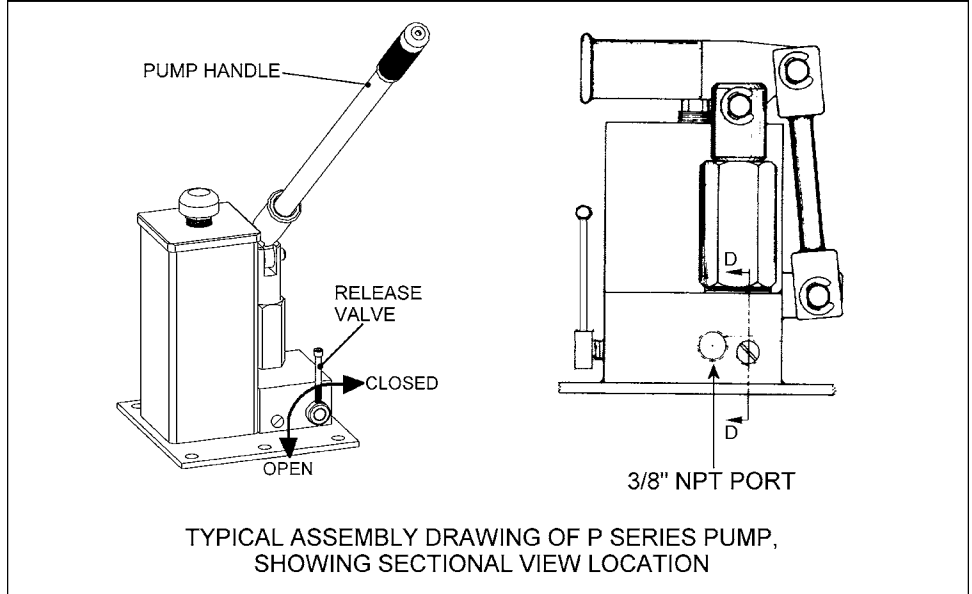

TROUBLE	POSSIBLE CAUSES	CORRECTIVE REPAIR INSTRUCTIONS
Pump will not hold pressure	<ol style="list-style-type: none"> 1. Release valve ball not seating properly 2. Ball valves not seating properly 3. Overload valve ball not seating properly 	Refer to RELEASE VALVE Refer to PUMP VALVE Refer to OVERLOAD VALVE
Pump fails to supply pressure	<ol style="list-style-type: none"> 1. Lack of oil 2. Air bound pump 3. Release valve ball not seating properly 4. Small ball in ball valve circuit not seating properly 5. Overload valve ball not seating properly 	Refer to OIL Refer to AIR BLEEDING Refer to RELEASE VALVE Refer to PUMP VALVE Refer to OVERLOAD VALVE
Pump piston does not draw a full charge. (This is evident by a cushion effect at the top of the pump stroke.)	<ol style="list-style-type: none"> 1. Air bound system 2. Lack of oil 	Refer to AIR BLEEDING Refer to OIL
Pump piston raises by itself under pressure	Large ball in ball valve circuit not seating properly	Refer to PUMP VALVE
Pump functions properly but will generate only a given pressure below its normal maximum pressure	Overload valve not set properly	Refer to OVERLOAD VALVE

Operator's Manual for Star Single Piston Hydraulic Pump

As installed on: 400 Series Serial # 0604 to ____ (MMYY)
405 Series Serial # 0604 to ____ (MMYY)
82 Series Serial # 0604 to ____ (MMYY)

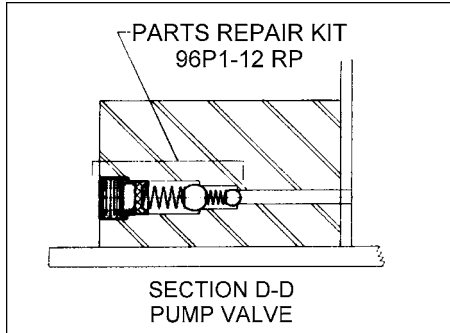

PUMP VALVE

If the pump fails to supply pressure or if the piston is under pressure at all times, the pump valve may need a cleaning. Stand pump in upright position while removing valve plug and valve seal. Tilt pump to remove valve springs and balls. Allow oil to drain from the reservoir through these valve holes to wash foreign matter from hole. Lay pump on its side to clean and inspect valve chamber. Be careful not to mar or nick ball valve seats. Clean valve balls and spring in solvent. Replace rusted or corroded balls. Do not stretch ball springs. To reassemble, insert, in sequence, small ball, small spring, large ball and large spring in cleaned chamber. Finally, screw in valve seal plug (96CP13-151RP).

If the valve fails to operate properly after cleaning it may be necessary to re-seat the valve balls. Remove the springs and tap each ball lightly in its respective seat using the 1/4" ball seating tool (96CP13-42) for the small ball and the 3/8" ball seating tool (96CP13-43) for the large ball. Remove balls to make sure they are not stuck to the seats. Reassemble pump valve as before. See "Air Bleeding" instructions before attempting to operate the pump.

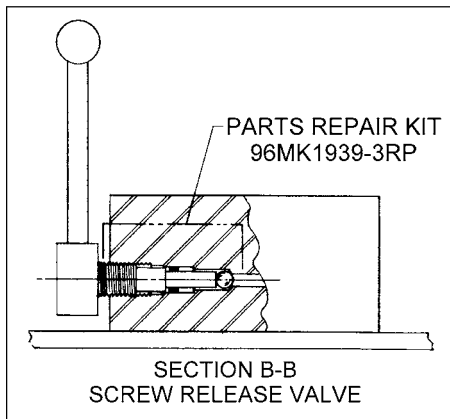

RELEASE VALVE - SCREW TYPE

If the pump fails to lift or hold a load, the release valve may be dirty. Remove release screw, release valve seal and 9/32" release valve ball. Clean and inspect valve seat and screw. A slight depression in the end of the screw is not harmful. Screws with excessive deformation should be replaced. Re-seat the release ball using the 1/4" ball seating tool (96CP13-42). Insert the release valve packing using the valve packing inserting tool (96P1A-40). Reinstall release screw. See "Air Bleeding" instructions before attempting to operate the pump.

PUMP PISTON

Leakage of oil around the pump piston indicates worn or damaged piston packing.

To replace packing:

1. Remove piston activating linkage.
2. Remove piston. (see piston drawing.)
3. Remove all packings. (see piston drawing.)
4. Clean all parts and dry with compressed air.
5. Install new packings, wipers and static seals, being sure, packing sealing lips, face down toward the pressure. (Dip each part into clean hydraulic oil before assembly.)
6. Open the release valve (to allow air to bleed from piston barrel back to reservoir) and insert the piston.
7. Replace piston linkage.
8. NOTE: With release valve open, stroke pump about a dozen times to bleed air completely from pump.

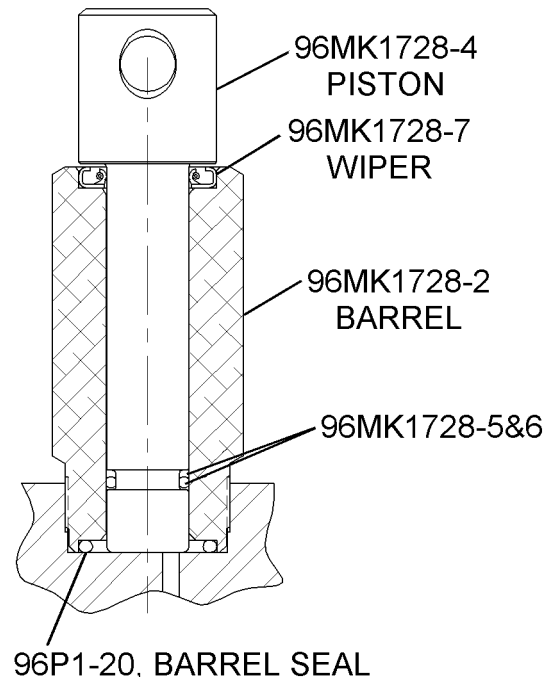

Operator's Manual for Star Single Piston Hydraulic Pump

As installed on: 400 Series Serial # 0604 to ____ (MMYY)
405 Series Serial # 0604 to ____ (MMYY)
82 Series Serial # 0604 to ____ (MMYY)

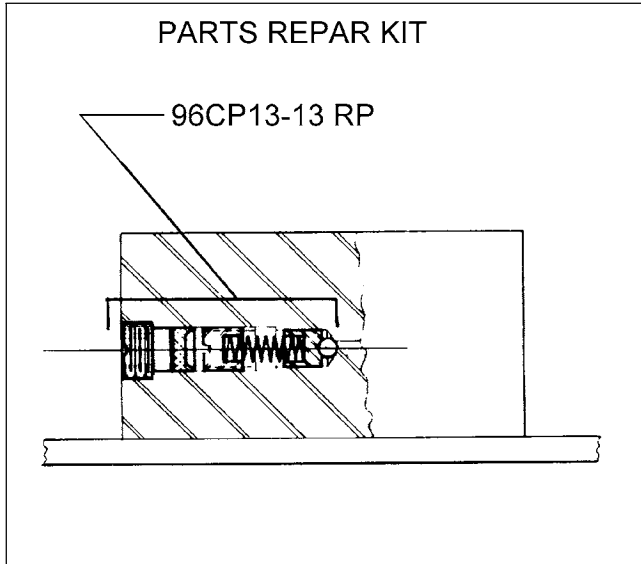

OVERLOAD VALVE

If the pump fails to lift or hold a load after the release valve and pump valves have been checked, the overload valve may be dirty. To clean valve, remove valve plug and valve plug seal. Using a screwdriver, remove overload valve screw. Tip pump forward to remove valve spring, valve plunger and steel ball. Clean and inspect valve hole. If the ball seat is marred, re-seat same by lightly tapping ball on seat using tool (96CP13-45). Remove ball to prevent sticking. Reassemble ball, plunger, spring and valve screw. Connect a pressure gauge to the pressure outlet. Stroke pump to obtain maximum desired pressure. Turn valve screw clockwise to increase pressure reading and counterclockwise to reduce maximum reading. After valve is set properly, replace valve seal plug (96CP13-151RP). See "Air Bleeding" instructions before attempting to operate the pump.

SPECIAL TOOLS AVAILABLE FOR REPAIRING STAR PUMPS ARE SHOWN BELOW

