

Option POLY-201 to roll 55-gallon plastic drum on Morse 201 Series Portable Drum Rollers

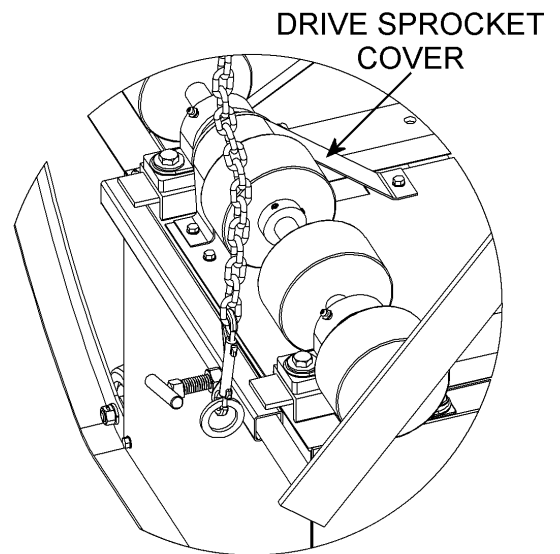
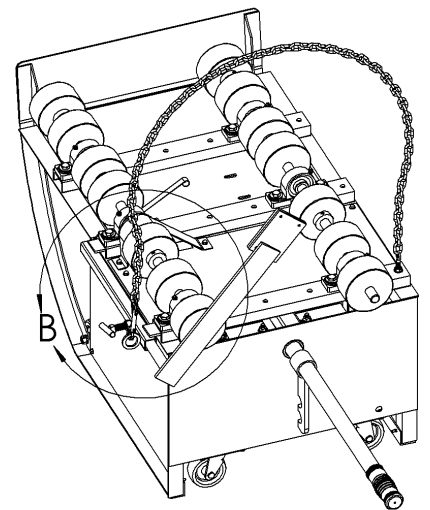
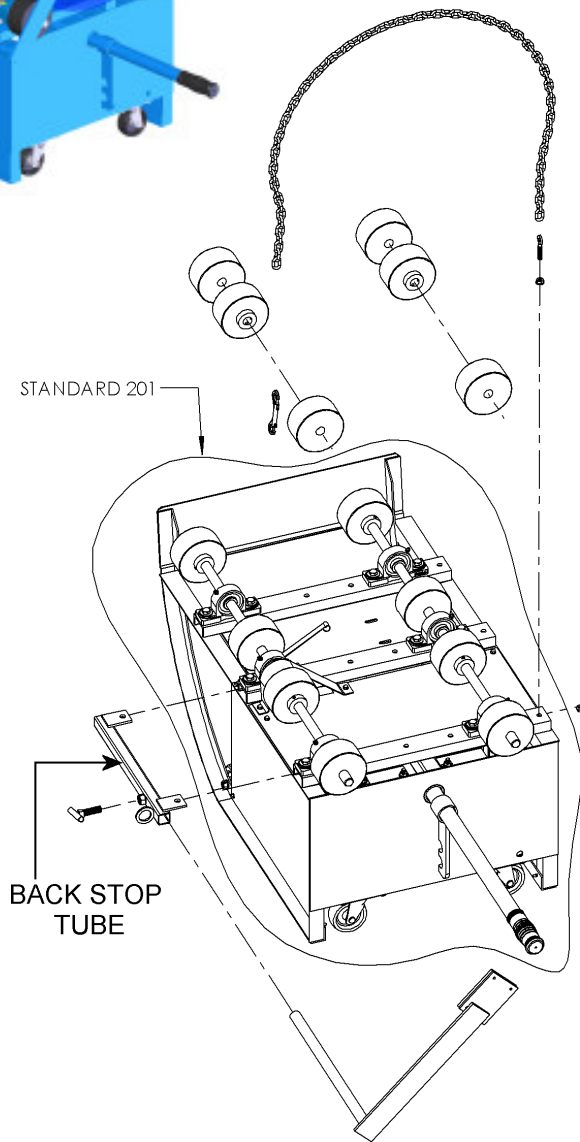
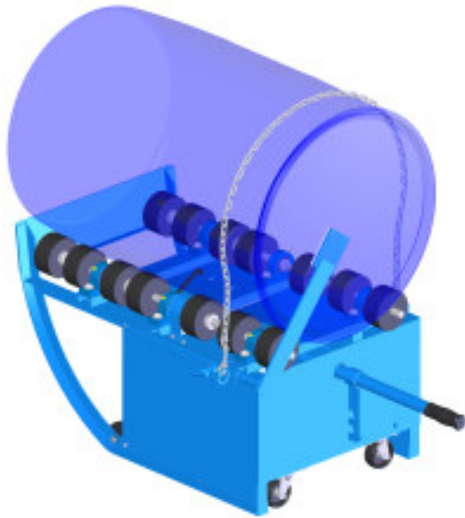

DETAIL B  
 SCALE 1 : 5

**Option POLY-201 to roll 55-gallon plastic drum on Morse 201 Series Portable Drum Rollers**

ITEM	QTY.	PART #	DESCRIPTION
1	1	575-P	SNAP HOOK, GR, 300
2	1	202-P	WHEEL, DRIVE OR IDLER, 4", 201
3	1	3988-P	CHAIN, 1/0 LOCK LINK, 66"
4	2	1634-P	NUT, 5/16-18 WHIZ LOCK
5	1	248-P	FHMS, 10-24 X 3/8
6	1	327-P	WEAR PAD, UHMW, TIVAR, 201B
7	1	3501-P	BACK STOP LEVER WELD, 201
8	1	1372-P	TEE HANDLE, HDPS, 1-1/2"
9	1	3499-P	BACK STOP TUBE WELD, 201
10	1	3281-P	HHCS, 3/8-16 X 1-1/2
11	1	1869-P	NUT, 10-24 NYLON LOCK
12	4	3292-P	WASHER, SAE #10, ID3/16"OD7/16
13	1	1867-P	BHSC, 10-24 X 1-1/2
14	1	M01327-P	BOLT, 5/16-18 X 1-7/8 EYE, MON

**For replacement parts, please contact your Morse dealer.**

**When ordering parts, please specify:**

- Part number and description,
- Model number
- Serial number

**Find model number and serial number on metal name plate attached to frame.**

Option POLY-201 to roll 55-gallon plastic drum on Morse 201 Series Portable Drum Rollers

