

**Assembly Instructions for Models 152 and 153 Drum Hand Trucks**

**Modified design as of 05/2004 requires some assembly and saves on shipping charges.**

1. Slide the Handle Assembly tube through the Hook Slide Weldment (item 3) and into the Base Assembly tube and align drilled holes.
2. Insert bolt (item 5) through the aligned holes and secure with Lock Nut (item 4) to fasten the Handle Assembly to the Base Assembly.

Note: Hook Slide Weldment slides freely on the Handle assembly tube to engage the upper rim of your drum.

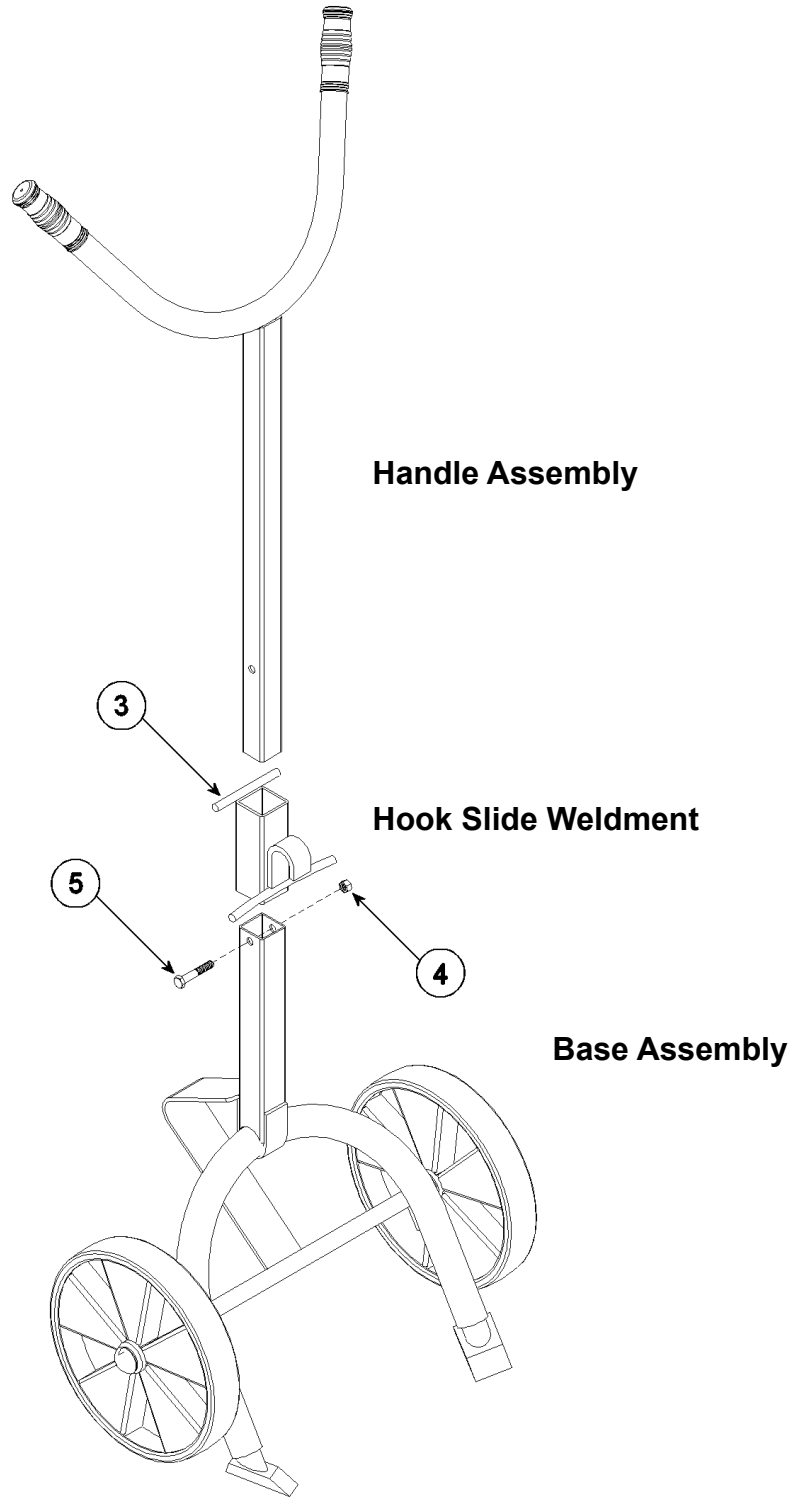

**Model 152 shown**

### Parts List and Diagram for Models 152 and 153 Drum Hand Trucks

For replacement parts, please contact your Morse dealer.

When ordering parts, please specify:

- Part number and description
- Model number
- Serial number

Find model number and serial number on metal name plate attached to frame.

| Morse Model 152 |     |        |                               |
|-----------------|-----|--------|-------------------------------|
| ITEM            | QTY | PART # | DESCRIPTION                   |
| 1               | 2   | 83-P   | GRIP, HANDLE, 1-1/4 X 4-1/2   |
| 2               | 1   | 3970-P | HANDLE WELD, 152, 153, 155    |
| 3               | 1   | 1947-P | HOOK SLIDE WELD, 152          |
| 4               | 1   | 1169-P | NUT, 3/8-16 REV HEX LOCK      |
| 5               | 1   | 82-P   | HHCS, 3/8-16 X 2-1/4 GR2      |
| 6               | 1   | 3971-P | BASE WELD, 152, 153           |
| 7               | 2   | 1953-P | WHEEL SPACER, 152, 153, 155   |
| 8 *             | 2   | 702-P  | WHEEL, RUBBER, 10", 7/8" BORE |
| 9 *             | 2   | 706-P  | CAP, HUB, PUSH-ON, 7/8"       |

| Morse Model 153 |     |        |                               |
|-----------------|-----|--------|-------------------------------|
| ITEM            | QTY | PART # | DESCRIPTION                   |
| 1               | 2   | 83-P   | GRIP, HANDLE, 1-1/4 X 4-1/2   |
| 2               | 1   | 3970-P | HANDLE WELD, 152, 153, 155    |
| 3               | 1   | 1947-P | HOOK SLIDE WELD, 152          |
| 4               | 1   | 1169-P | NUT, 3/8-16 REV HEX LOCK      |
| 5               | 1   | 82-P   | HHCS, 3/8-16 X 2-1/4 GR2      |
| 6               | 1   | 3971-P | BASE WELD, 152, 153           |
| 7               | 2   | 1953-P | WHEEL SPACER, 152, 153, 155   |
| 8 *             | 2   | 701-P  | WHEEL, MORTUF, 10", 7/8" BORE |
| 9 *             | 2   | 706-P  | CAP, HUB, PUSH-ON, 7/8"       |

\* Recommended spare parts.

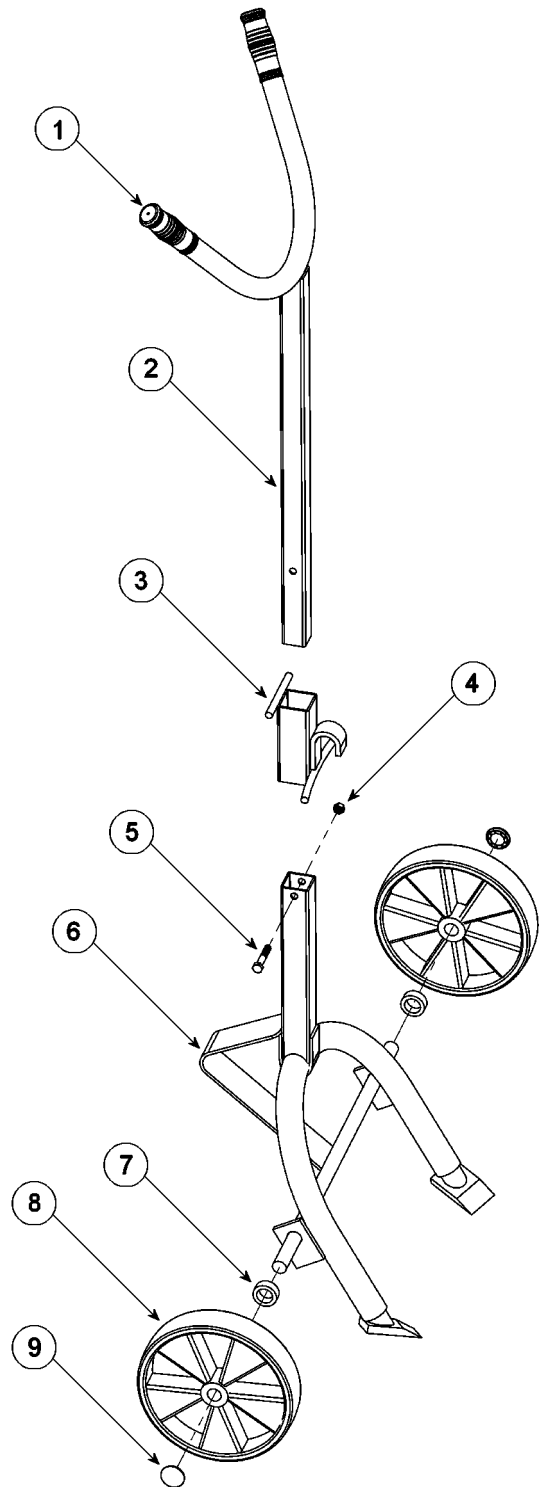

Model 153 shown